

# HYDRONIC

**Technical description, installation,  
operation and maintenance instructions.**

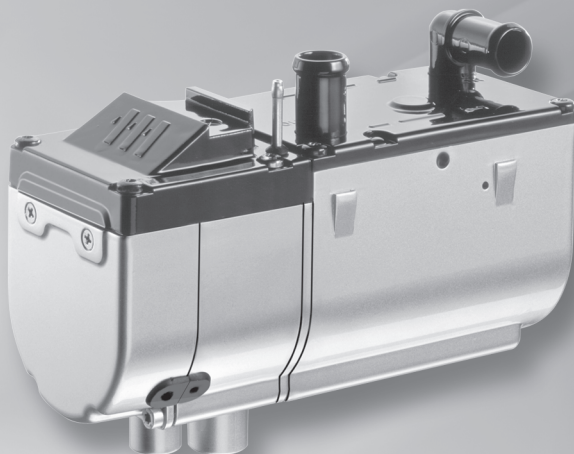

Heater	Order no.	Heater	Order no.
<i>HYDRONIC B 5 W S – 12 Volt</i>	20 1819 05 00 00	<i>HYDRONIC D 5 W S – 12 Volt</i>	25 2217 05 00 00
<i>HYDRONIC B 5 W S – 12 Volt as complete package</i>	20 1822 05 00 00	<i>HYDRONIC D 5 W S – 12 Volt as complete package</i>	25 2228 05 00 00
		<i>HYDRONIC D 5 W S – 24 Volt</i>	25 2218 05 00 00

**Water heater for diesel and petrol  
operating independently of the engine.**



**Eberspächer**

# 1 Introduction

## Contents

Chapter	Title	Contents	Page
1	Introduction	<ul style="list-style-type: none"><li>• Contents ..... 2</li><li>• Concept of this manual ..... 3</li><li>• Special text structure, presentation and picture symbols ..... 4</li><li>• Important information before starting work ..... 4</li><li>• Statutory regulations ..... 5, 6</li><li>• Safety instructions for installation and operation ..... 7</li><li>• Accident prevention ..... 7</li></ul>	
2	Product information	<ul style="list-style-type: none"><li>• Scope of supply petrol heaters ..... 8, 9</li><li>• Scope of supply diesel heaters ..... 10, 11</li><li>• Technical data petrol heaters ..... 12</li><li>• Technical data diesel heaters ..... 13</li><li>• Main dimensions ..... 14</li></ul>	
3	Installation	<ul style="list-style-type: none"><li>• Installation and location ..... 15</li><li>• Possible installation positions ..... 16</li><li>• Mounting and fastening ..... 17</li><li>• Nameplate ..... 18</li><li>• Connection to the cooling water circuit ..... 19 – 22</li><li>• Exhaust system ..... 23</li><li>• Combustion air system ..... 24</li><li>• Fuel supply petrol heaters ..... 25 – 29</li><li>• Fuel supply diesel heaters ..... 25 – 29</li></ul>	
4	Operation and function	<ul style="list-style-type: none"><li>• Operating instructions / important information for operation ..... 30</li><li>• Initial commissioning ..... 30</li><li>• Description of functions ..... 30</li><li>• Control and safety devices ..... 31</li></ul>	
5	Electrical system	<ul style="list-style-type: none"><li>• Heater wiring ..... 32</li><li>• Parts list for the circuit diagrams ..... 32 – 34</li><li>• Circuit diagrams at the end of this manual</li></ul>	
6	Troubleshooting Maintenance Service	<ul style="list-style-type: none"><li>• In case of faults, please check the following points ..... 35</li><li>• Troubleshooting ..... 35</li><li>• Maintenance instructions ..... 35</li><li>• Service ..... 35</li></ul>	
7	Environment	<ul style="list-style-type: none"><li>• Certification ..... 36</li><li>• Disposal ..... 36</li><li>• EU Declaration of Conformity ..... 36</li></ul>	
8	Lists	<ul style="list-style-type: none"><li>• List of key words ..... 37, 38</li><li>• List of abbreviations ..... 38</li></ul>	



# 1 Introduction

---

## Concept of this manual

This manual aims to support the service company installing the heater and to provide the user with all important information about the heater. The manual has been divided into 8 chapters to make it easier to find the corresponding information quickly.

### 1 Introduction

Here you will find important introductory information about installation of the heater and about the structure of the manual.

### 2 Product information

Here you will find information about the scope of supply, the technical data and the dimensions of the heater.

### 3 Installation

Here you will find important information and instructions referring to installation of the heater.

### 4 Operation and function

Here you will find information about the operation and function of the heater.

### 5 Electric system

Here you will find information about the electronic system and electronic components of the heater.

### 6 Troubleshooting / maintenance / service

This section contains information on possible faults and malfunctions, troubleshooting, maintenance and the service hotline.

### 7 Environment

Here you will find information about certification and disposal of the heater together with the EU Declaration of Conformity.

### 8 Lists

Here you will find the key word list and abbreviations list.

# 1 Introduction

## Special text structure, presentation and picture symbols

This manual uses special text structures and picture symbols to emphasise different contents. Please refer to the examples below for the corresponding meanings and associated actions.

### Special structure and presentations

A dot (•) indicates a list which is started by a heading. If an indented dash (–) follows a dot, this list is subordinate to the dot.

### Picture symbols



#### Regulation!

This picture symbol with the remark "Regulation" refers to a statutory regulation. Failure to comply with this regulation results in expiry of the type permit for the heater and preclusion of any guarantee and liability claims on J. Eberspächer GmbH & Co. KG and its associated companies.



#### Danger!

This picture symbol with the remark "Danger!" refers to the risk of a fatal danger to life and limb. Under certain circumstances, failure to comply with these instructions can result in severe or life-threatening injuries.



#### Caution!

This picture symbol with the remark "Caution!" refers to a dangerous situation for a person and / or the product. Failure to comply with these instructions can result in injuries to people and/or damage to machinery.



These remarks contain application recommendations and useful tips for installation of the heater.

## Important information before starting work

### Range of application of the heater

The water heater operating independently of an engine is intended for installation in the following vehicles, depending on its heating output:

- Vehicles of all kinds
- Construction machinery
- Agricultural machinery
- Boats, ships and yachts

#### Please note!

Installation of the heater in vehicles used for the transport of dangerous goods as per ADR / ADR99 is only permitted for *HYDRONIC D 5 W S* – 24 volt.

### Purpose of the heater (using the vehicle heat exchanger)

- Pre-heating, de-misting windows
- Heating and keeping the following warm:
  - Driver and working cabs
  - Freight compartments
  - Ship's cabins
  - Passenger and crew compartments
  - Vehicle engines and units

On account of its functional purpose, the heater is not permitted for the following applications:

- Long-term continuous operation, e.g. for pre-heating and heating of:
  - Residential rooms
  - Garages
  - Work huts, weekend homes and hunting huts
  - Houseboats, etc.



#### Caution!

### Safety instructions for application and proper purpose

- The heater must only be used and operated for the range of application stated by the manufacturer in compliance with the "Operating instructions" included with every heater.



# 1 Introduction

## Statutory regulations

The Federal Road Transport Directorate has issued an "EC type approval" and an "EMC type approval" for the heater for installation in motor vehicles and with the following official type approval marks, noted on the heater name plate.

HYDRONIC EC-e100 0023

EMC-e1031075



### Regulation!

#### Directive 2001 / 56 / EU of the European Parliament and the Council

##### • Arrangement of the heater

- Parts of the structure and other components near the heater must be protected from excess heat exposure and possible contamination from fuel or oil.
- The heater must not pose a fire hazard even when it overheats.  
This requirement is deemed to be fulfilled when adequate clearance to all parts is observed during installation, sufficient ventilation is provided and fire-proof materials or heat plates are used.
- The heater must not be located in the passenger compartment in vehicles of class M<sub>1</sub>, M<sub>2</sub>, M<sub>3</sub> and N. A unit may however be used in a hermetically sealed housing which also corresponds to the conditions stated above.
- The factory nameplate or duplicate must be affixed so that it can still be easily read when the heater is installed in the vehicle.
- All appropriate precautions must be taken when arranging the heater to minimise the risk of injuries to persons or damage to other property.

##### • Fuel supply

- The fuel intake connection must not be located in the passenger compartment and must be sealed with a properly closing lid to prevent any fuel leaks.
- In heaters for liquid fuel where the heater fuel is separate from the vehicle fuel, the type of fuel and intake connection must be clearly identified.

- A warning sign is to be fixed to the intake connection indicating that the heater must be switched off before refuelling.

##### • Exhaust system

- The exhaust outlet must be arranged so as to prevent any penetration of exhaust fumes into the vehicle interior through the ventilation system, warm air intakes or open windows.

##### • Combustion air intake

- The air for the heater combustion chamber must not be sucked in from the passenger compartment of the vehicle.
- The air intake must be arranged or protected in such a way that it cannot be blocked by other objects.

##### • Operating status display

- A clearly visible operating display in the user's field of vision must indicate when the heater is switched on and off.



### Regulation!

#### Mounting the heater in a vehicle for the transport of dangerous goods as per ADR / ADR99

- When the heater is to be installed in vehicles for the transport of dangerous goods, the regulations of ADR / ADR 99 must also be observed. Detailed information about the regulations of ADR / ADR 99 are contained in the information leaflet no. 25 2161 95 15 80 (see also page 16 and 31).

# 1 Introduction

## § Regulations

### Additional regulations for certain vehicles named in Directive 94 / 55 / EC (ADR Framework Directive)

#### Scope

This appendix applies to vehicles for which the special provisions of Directive 94 / 55 / EC apply to combustion heaters and their installation.

#### Definition of terms used

For the purposes of this appendix, the vehicle designations "EX / II", "EX / III", "AT", "FL" and "OX" according to Chapter 9.1 of Annex B of Directive 94 / 55 / EC are used.

#### Technical regulations

##### General provisions (EX / II, EX / III, AT, FL and OX vehicles)

##### Avoid heating and ignition

The combustion heaters and their exhaust gas routing shall be designed, located, protected or covered so as to prevent any unacceptable risk of heating or ignition of the load. This requirement shall be considered as fulfilled if the fuel tank and the exhaust system of the appliance conform to provisions in 3.1.1.1 and 3.1.1.2. Compliance with these regulations shall be checked in the complete vehicle.

##### Fuel tanks

Fuel tanks for supplying the heater shall conform to the following regulations:

- In the event of any leakage, the fuel shall drain to the ground without coming into contact with hot parts of the vehicle or the load;
- fuel tanks containing petrol shall be equipped with an effective flame trap at the filler opening or with a closure enabling the opening to be kept hermetically sealed.

##### Exhaust system and exhaust pipe layout

The exhaust system as well as the exhaust pipes shall laid out or protected to avoid any danger to the load through heating or ignition. Parts of the exhaust system situated directly below the fuel tank (diesel) shall have a clearance of at least 100 mm or be protected by a thermal shield.

##### Switching on the combustion heater

The combustion heater may only be switched on manually. Automatic switching on via a programmable switch is not permitted.

##### EX / II and EX / III vehicles

Combustion heaters for gaseous fuels are not permitted.

##### FL vehicles

Combustion heaters must be able to be taken out of service/disabled at least by the methods described in the following:

- a) Switching off manually in the driver's cabin
- b) Switching off the vehicle's engine; in this case the heater may be manually switched back on by the vehicle driver;
- c) Starting up of a feed pump installed in the vehicle for the dangerous goods carried.

##### Combustion heater after-run

After-running of the switched off combustion heater is permitted. In the cases named in the "FL vehicles" paragraph under letters b) and c) the supply of combustion air must be interrupted by suitable means after a maximum after-run period of 40 seconds. Only combustion heaters whose heat exchangers are verifiably not damaged by the reduced after-run period of 40 seconds beyond their usual use period may be used.

#### Please note!

- Compliance with the statutory regulations, the additional regulations and safety instructions is prerequisite for guarantee and liability claims. Failure to comply with the statutory regulations and safety instructions and incorrect repairs even when using original spare parts make the guarantee null and void and preclude any liability for J. Eberspächer GmbH & Co. KG.
- Subsequent installation of this heater must comply with these installation instructions.
- The statutory regulations are binding and must also be observed in countries which do not have any special regulations.
- When the heater is to be installed in vehicles not subject to the German Ordinance for the Registration of Motor Vehicles (StVZO), for example ships, the specially valid regulations and installation instructions for these special applications must be observed.
- Installation of the heater in special vehicles must comply with the regulations applying to such vehicles.
- Other installation requirements are contained in the corresponding sections of this manual.



# 1 Introduction

## Safety instructions for installation and operation



### Danger!

#### Risk of injury, fire and poisoning

- Disconnect the vehicle battery before starting any kind of work.
- Before working on the heater, switch the heater off and let all hot components cool down.
- The heater must not be operated in enclosed rooms, e.g. in the garage or multi-storey car park.
- Before the heater is installed again in another vehicle, rinse the heater parts carrying water with clear water.
- When carrying out electric welding on the vehicle, the plus pole cable at the battery should be disconnected and placed at ground to protect the controller.



### Caution!

#### Safety instructions for installation and operation

- The heater must only be installed by a JE partner authorised by the manufacturer according to the instructions in this manual and possibly according to special installation recommendations; the same applies to any repairs to be carried out in the case of repairs or guarantee claims.
- Repairs by non-authorized third-parties or with not original spare parts are dangerous and therefore not allowed. They result in expiry of the type permit of the heater; consequently, when installed in motor vehicles they can cause expiry of the vehicle operating licence.
- The following measures are not allowed:
  - Changes to components relevant to the heater.
  - Use of third-party components not approved by J. Eberspächer GmbH & Co. KG.
  - Nonconformities in installation or operation from the statutory regulations, safety instructions or specifications relevant to safe operation as stated in the installation instructions and operating instructions. This applies in particular to the electrical wiring, fuel supply, combustion air system and exhaust system.
- Only original accessories and original spare parts must be used during installation or repairs.
- Only original accessories and spare parts may be used for installation or repairs.
- Only the controls approved by Eberspächer may be used to operate the heater. The use of other controls can result in malfunctions.
- The heater must not be operated where there is a risk of an accumulation of flammable vapours or dust, for example close to
  - fuel depot
  - coal depot
  - wood depot
  - grain depots etc.
- The heater must be switched off when refuelling.
- When the heater is mounted in a safety housing etc., the installation compartment of the heater is not a stowage compartment and must be kept clear. In particular fuel canisters, oil cans, spray cans, gas cartridges, fire extinguishers, cleaning rags, items of clothing, paper etc. must not be stored or transported on or next to the heater.
- Defect fuses must only be replaced by fuses with the prescribed rating.
- If fuel leaks from the heater fuel system, arrange for the damage to be repaired immediately by a JE service partner.
- When topping up the coolant, only use the coolant permitted by the vehicle manufacturer, see the vehicle operating manual. Any blending with unpermitted coolant can cause damage to the engine and heater.
- After-running of the heater must not be interrupted prematurely e.g. by pressing the battery disconnecting switch, apart from in the case of an emergency stop.

## Accident prevention

General accident prevention regulations and the corresponding workshop and operation safety instructions are to be observed.

## 2 Product information

### Scope of supply for petrol heaters

Quantity / Designation	Order number
1 HYDRONIC B 5 W S – 12 V	20 1819 05 00 00

To be ordered separately:

1 Universal installation kit	20 1819 80 00 00
1 Control unit*	----

or

1 HYDRONIC B 5 W S – 12 V as complete package**	20 1822 05 00 00
--	------------------

To be ordered separately:

1 Control unit*	----
-----------------	------

\* Control units see price list /  
accessories catalogue

\*\* Complete package contains:  
1 Heater  
1 Universal installation kit

### Parts list for the picture "Scope of supply" on page 9

#### Scope of supply for petrol heater

##### Picture No. Designation

1	Heater
2	Dosing pump
3	Waterpump

#### Scope of supply for universal installation kit

##### Picture No. Designation

4	Exhaust silencer
5	Cable tree, heater
6	Cable harness, plus
7	Heater bracket
8	Water hose
9	Flexible exhaust pipe
10	Cable tape
11	Bracket of perforated tape
12	Bracket, dosing pump
13	Pipe, 6 x 2
14	Combustion air hose
15	Hose, 5 x 3
16	Pipe, 4 x 1
17	Bracket, water pump

### Cable harnesses

- (A) Cable harness "Controls"
- (B) Cable harness "Fan control"
- (C) Plus cable
- (D) Minus cable

#### Please note!

- Parts without picture number are small parts and packed in a bag.
- Please consult the additional parts catalogue if any other parts are required for installation.





## 2 Product information

### Scope of supply for petrol heaters

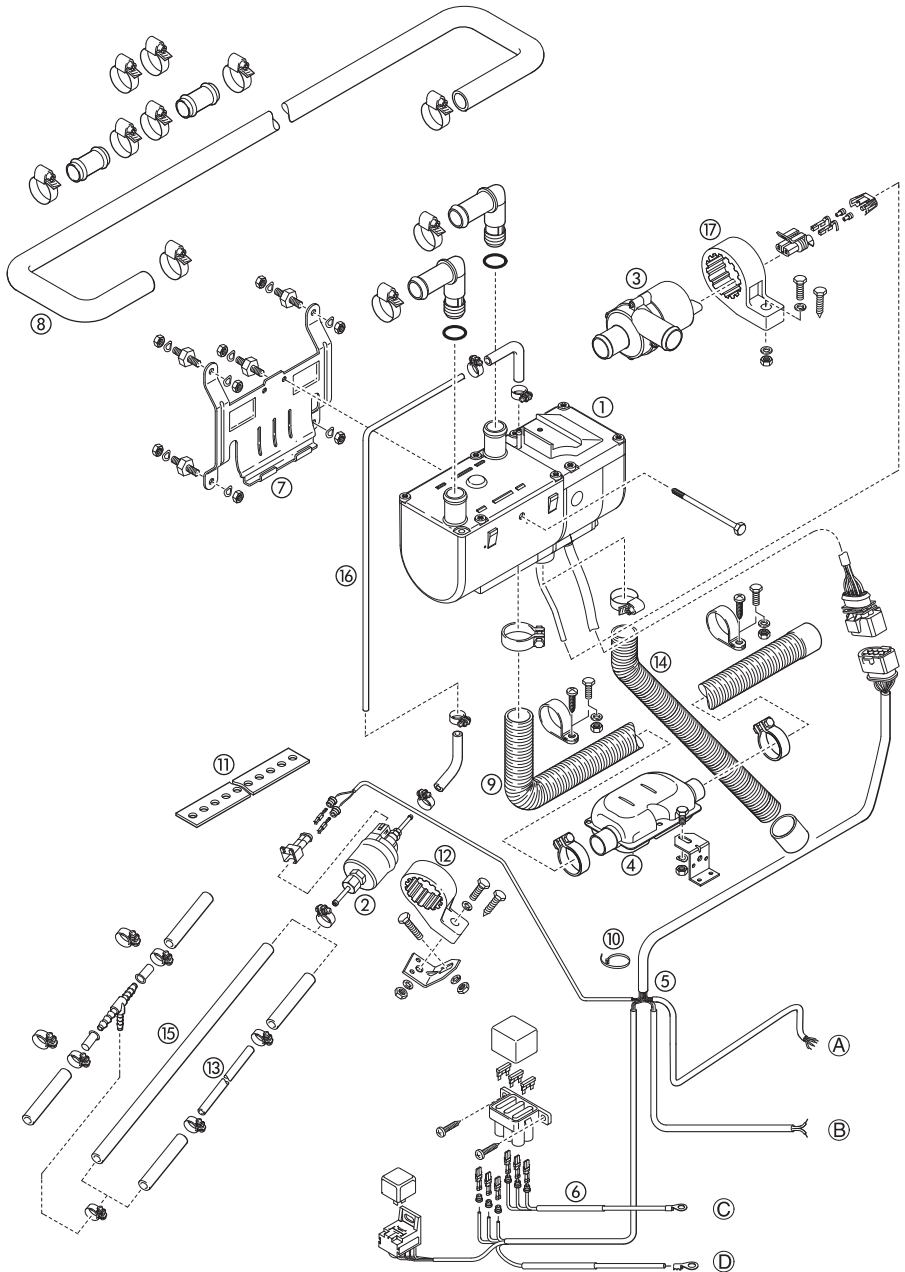

## 2 Product information

### Scope of supply for diesel heaters

Quantity / Designation	Order number
1 <i>HYDRONIC</i> D 5 W S – 12 V	25 2217 05 00 00
To be ordered separately:	
1 Universal installation kit	20 1819 80 00 00
1 Control unit*	----
or	
1 <i>HYDRONIC</i> D 5 W S – 12 V as complete package**	25 2228 05 00 00
To be ordered separately:	
1 Control unit*	----
1 <i>HYDRONIC</i> D 5 W S – 24 V	25 2218 05 00 00
To be ordered separately:	
1 Universal installation kit	25 2218 80 00 00
1 Control unit*	----
* Control units see price list / accessories catalogue	
** Complete package contains: 1 Heater 1 Universal installation kit	

### Parts list for the picture "Scope of supply" on page 11

#### Scope of supply for diesel heater

Picture No.	Designation
1	Heater
2	Dosing pump
3	Waterpump

#### Scope of supply for universal installation kit

Picture No.	Designation
4	Exhaust silencer
5	Cable tree, heater
6	Cable harness, plus
7	Heater bracket
8	Water hose
9	Flexible exhaust pipe
10	Cable tape
11	Bracket of perforated tape
12	Bracket, dosing pump
13	Pipe, 6 x 2
14	Combustion air hose
15	Hose, 5 x 3
16	Pipe, 4 x 1
17	Bracket, water pump
18	Tank connection (only contained in installation kit order No. 25 2218 80 00 00)

### Cable harnesses

- (A) Cable harness "Controls"
- (B) Cable harness "Fan control"
- (C) Plus cable
- (D) Minus cable

#### Please note!

- Parts without picture number are small parts and packed in a bag.
- Please consult the additional parts catalogue if any other parts are required for installation.



## 2 Product information

### Technical data for petrol heaters

Heater		<b>B 5 W S</b>	
Heating medium		Water, cooling fluid	
Control of the heat flow		Large	Small
Heat flow (watt)		5000	1500
Fuel consumption (l/h)		0.69	0.2
Mean electr. power (watt)	in operation	37	10
	at start	110	
	after-running	8	
Electr. power of water pump		16 watt	
Rated voltage		12 volt	
Operating range		10.2 volt	
<ul style="list-style-type: none"> <li>Lower voltage limit: An undervoltage protection in the controller switches the heater off on reaching approx 10 volt.</li> </ul>			
<ul style="list-style-type: none"> <li>Upper voltage limit: An overvoltage protection in the controller switches the heater off on reaching approx 16 volt.</li> </ul>		16 volt	
Tolerable operating pressure		up to 2.5 bar overpressure	
Flow rate of the water pump at 0.1 bar		800 l/h	
Minimum water flow rate of the heater		250 l/h	
Fuel (see also fuel supply, page 29)		Commercially available petrol (DIN EN 228)	
Tolerable operating temperature	Operation heater	-40 °C to +80 °C	
	Operating, dosing pump	-40 °C to +20 °C	
	Storage	-40 °C to +105 °C	
Interference suppression class		5 for VHF, SW, MW, 2 for LW	
Weight			
<ul style="list-style-type: none"> <li>Without controller and cooling fluid</li> </ul>		ca. 2.3 kg	
<ul style="list-style-type: none"> <li>With dosing pump and water pump</li> </ul>		ca. 2.9 kg	



#### Caution!

#### Safety instructions for technical data!

Failure to comply with the technical data can result in malfunctions.

All technical data ±10 %



## 2 Product information

### Technical data for diesel heaters

Heater		<b>D 5 W S</b>		
Heating medium		Water, cooling fluid		
Control of the heat flow		Large	Small	
Heat flow (watt)		5000	2400	
Fuel consumption (l/h)		0.62	0.27	
Mean electr. power (watt)	in operation	37	10	
	at start	110		
	after-running	8		
Electr. power of water pump		16 watt	16 watt	12 watt
Rated voltage		12 volt	12 volt	24 volt
Operating range				
<ul style="list-style-type: none"> <li>Lower voltage limit: An undervoltage protection in the controller switches the heater off on reaching approx 10 v.</li> </ul>		10.2 volt	10.2 volt	20.4 volt
<ul style="list-style-type: none"> <li>Upper voltage limit: An overvoltage protection in the controller switches the heater off on reaching approx 16 v.</li> </ul>		16 volt	16 volt	32 volt
Tolerable operating pressure		up to 2.5 bar overpressure		
Flow rate of the water pump at 0.1 bar		800 l/h	800 l/h	950 l/h
Minimum water flow rate of the heater		250 l/h		
Fuel (see also fuel supply, page 29)		Commercially available diesel (DIN EN 590)  PME (DIN V 51606) only for D 5 W S, 24 Volt		
Tolerable operating temperature	Operation heater	-40 °C to +80 °C		
	Operating, dosing pump	-40 °C to +80 °C		
	Storage	-40 °C to +105 °C		
Interference suppression class		5 for VHF, SW, MW, 2 for LW		
Weight				
<ul style="list-style-type: none"> <li>Without controller and cooling fluid</li> </ul>		ca. 2.3 kg		
<ul style="list-style-type: none"> <li>With dosing pump and water pump</li> </ul>		ca. 2.9 kg		



#### Caution!

#### Safety instructions for technical data!

Failure to comply with the technical data can result in malfunctions.

All technical data  $\pm 10\%$

## 2 Product information

### Main dimensions heater

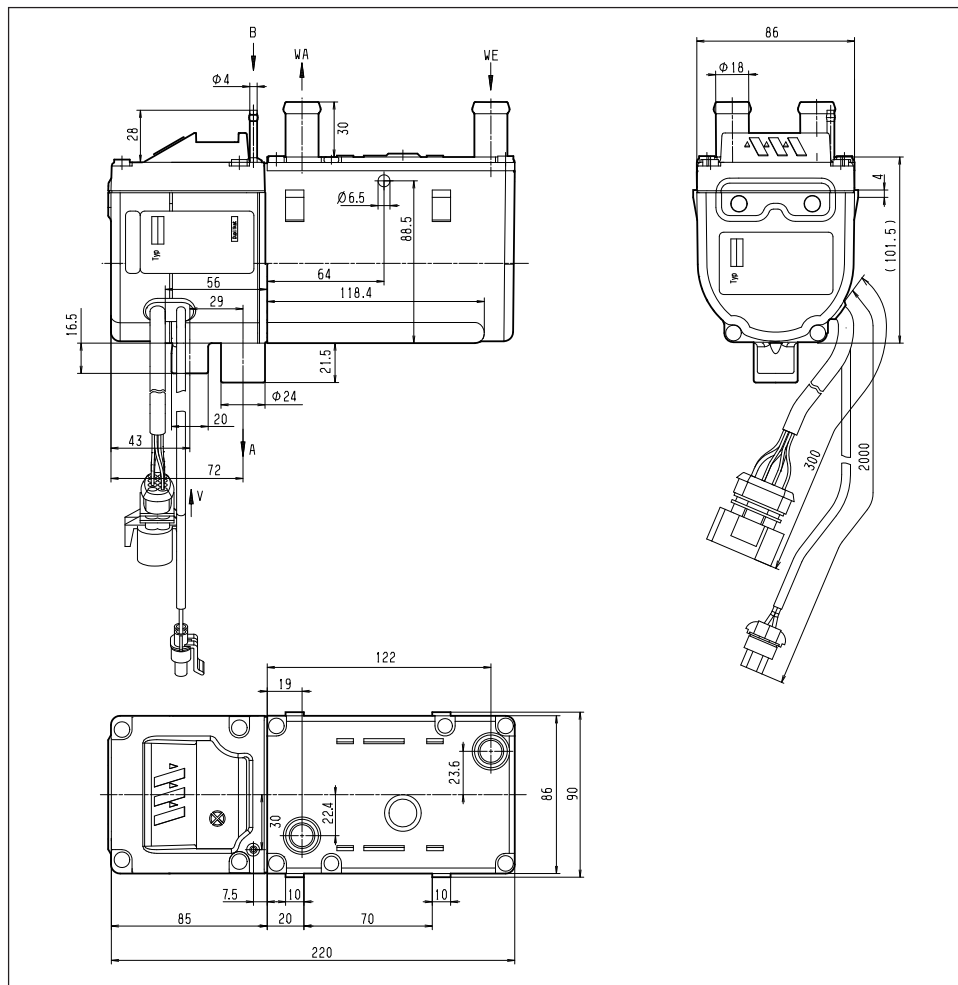

### Main dimensions water pump

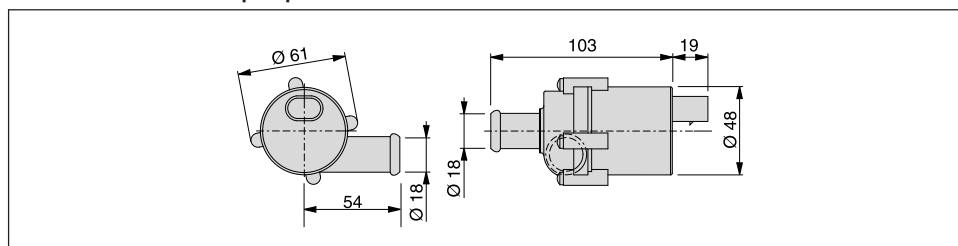

### 3 Installation

#### Installation location

The installation location for the heater is the engine compartment. The heater must be mounted below the min. cooling water level (compensation tank, cooler, vehicle heat exchanger) for automatic venting of the heat exchanger of the heater and the water pump.

#### Please note!

- In a truck, the water heater is preferably fastened underneath the driver's cab in the longitudinal beam near the vehicle engine.
- The regulations and safety instructions to be observed for this chapter are stated on page 4 – 7.
- The installation suggestions made in the installation instructions are examples. Other installation locations are possible if they correspond to the installation requirements stated in these installation instructions.
- Other installation information (e.g. for boats and ships) is available from the manufacturer on request.

#### Installation example

##### Petrol heater / diesel heater in a car

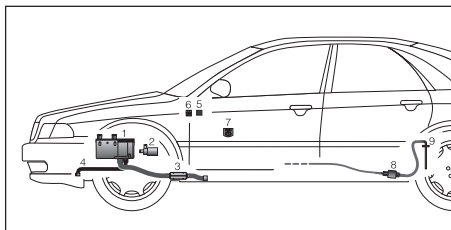

- ① Heater
- ② Water pump
- ③ Exhaust pipe with exhaust silencer
- ④ Combustion air intake silencer
- ⑤ Fan relay
- ⑥ Fuse bracket
- ⑦ Mini timer
- ⑧ Dosing pump
- ⑨ Rising pipe

#### Installation example

##### Diesel heater in a truck and in a delivery van

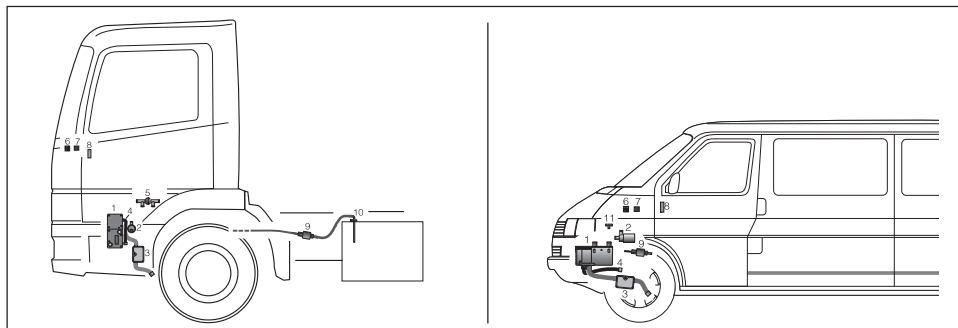

- ① Heater
- ② Water pump
- ③ Exhaust pipe with exhaust silencer
- ④ Combustion air hose
- ⑤ Non-return valve
- ⑥ Fuse holder

- ⑦ Fan relay
- ⑧ Mini timer
- ⑨ Dosing pump
- ⑩ Rising pipe
- ⑪ T-piece for fuel

### 3 Installation

#### Installing the 24 volt heater in a vehicle for transporting dangerous goods as per ADR / ADR99

For installation of the heater in vehicles for the transport of dangerous cargo, the regulations of ADR / ADR 99 must be observed.

The heater fulfils the regulations of ADR / ADR 99 with the corresponding electrical wiring, see circuit diagrams at the end of this manual.

Detailed information about the ADR / ADR 99 regulations is contained in leaflet No. 25 2161 95 15 80.

#### Possible installation positions

The heater should preferably be installed in the normal position, horizontal with the exhaust connection down to the bottom.

Depending on the installation conditions, the heater can also be mounted in the permitted swivel range, see diagram.

When the heater is operating, the shown normal or maximum installation positions can be varied briefly by up to +15° in all directions. Such deviations caused by the inclined position of the vehicle do not impair the heater functions in any way.

#### Heater in normal position with permitted swivel range

Swivel range from the normal position up to max. 90° swivel upwards.

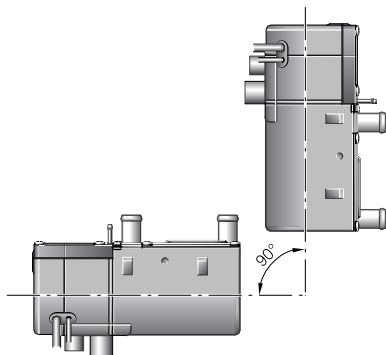

#### Water pump in normal position with permitted swivel range

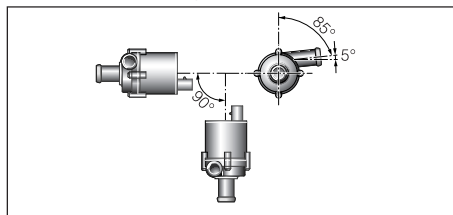

#### Please note!

The pressure connection must point 5° upwards, as shown in the diagram.

Swivel range from the normal position to max. 90° swivel around the longitudinal axis.

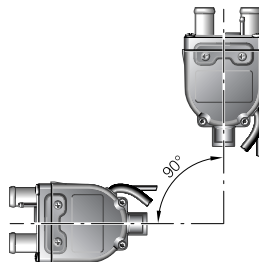





## 3 Installation

### Mounting and fastening

Position the heater in the holding clips of the heater bracket and fasten with fastening screw, M6 x 97 (torque 6<sup>9</sup>5Nm). Mount the heater bracket in a suitable position in the engine compartment, possibly using anti-vibration pads if necessary.

#### Please note!

Depending on the installation space available, the heater can be moved sideways in the bracket and screwed in one of the two fastening threads.

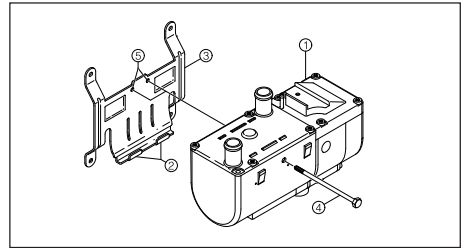

- ① Heater
- ② Bracket clips
- ③ Bracket holder
- ④ Fastening screw
- ⑤ Fastening thread

### Mounting the angled water connection

The heater is supplied with a straight water connection. Depending on the installation conditions, it may be necessary to mount an angled water connection.

- Unscrew the fastening screws on the cover and remove the cover.
- Press the straight water connection down.
- Loosen the indented ring and remove the O-ring seal.
- Pull the water connection out of the cover.
- Insert the angled water connection into the cover, insert the new O-ring seal in the provided groove and grease lightly.
- Mount the indented ring to the angled water connection, turn the water connection according to the installation position and insert in the toothed rim of the cover.
- Screw the cover to the housing again using 4 screws, torque 4 Nm.

If the previous screw opening is covered by the angled water connection, the neighbouring screw hole will have to be used instead.

Please proceed as follows:

- Cut a thread in the bore of the aluminium housing; to do so, screw a tapping screw into the bore and unscrew it again.
- Place the cover on the housing and screw in all four screws – torque 4.5 Nm.

#### Please note!

The thread must be cut before mounting the cover.

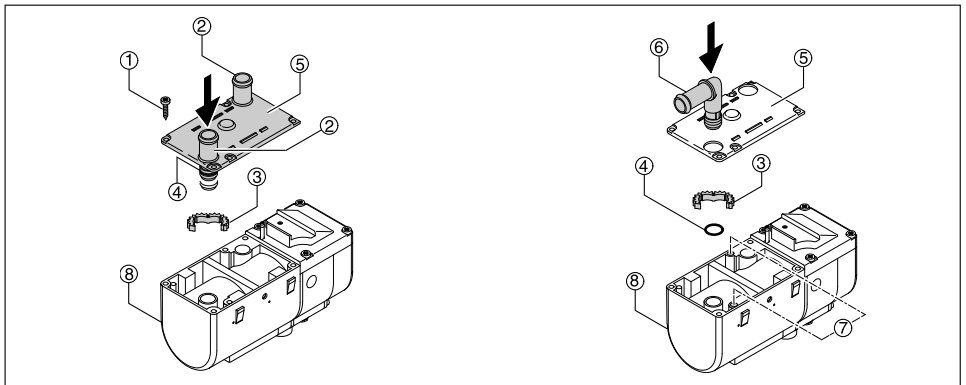

- ① Fastening screws
- ② Straight connection
- ③ Indented ring
- ④ O-ring

- ⑤ Cover
- ⑥ Angled connection
- ⑦ Bore holes
- ⑧ Heater

### 3 Installation

#### Nameplate

The nameplate is fastened to the front of the heater. The second nameplate (duplicate) is included in the scope of supply of the heater.

If required, the duplicate nameplate can be adhered in a clearly visible position on the heater or near to the heater.

**Please note!**

The regulations and safety instructions to be observed for this chapter are stated on page 5.

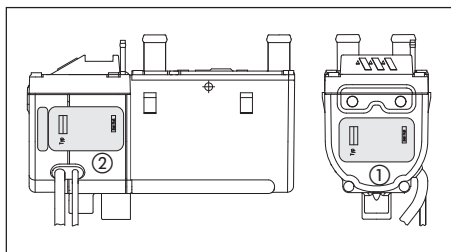

- ① Original nameplate
- ② 2<sup>nd</sup> nameplate (duplicate)



## 3 Installation

### Connection to the cooling water circuit

The heater is connected to the cooling water circuit in the water feed pipe from the vehicle engine to the heat exchanger. There are four possible alternative installations here.

The alternatives are described on pages 20 – 22.



#### Danger!

#### Risk of injuries and burns!

It is possible for the coolant and components of the coolant circuit to get very hot.

- Parts conveying water must be routed and fastened in such a way that they pose no temperature risk to man, animals or material sensitive to temperature from radiation / direct contact.
- Before working on the coolant circuit, switch the heater off and wait until all components have cooled down completely, if necessary where safety gloves.

#### Please note!

- When installing the heater and the water pump, please note the direction of flow of the coolant circuit.
- Fill the heater and water hoses with coolant before connecting to the coolant circuit.
- Route the water hoses without any kinks, and in a rising position if possible.
- When routing the water pipes, observe a sufficient clearance to hot vehicle parts.
- Protect all water hoses / water pipes from chafing and from extreme temperatures.
- Secure all hose connections with hose clips.
- After the vehicle has been operating for 2 hours or travelled 100 km, tighten the hose clips again.
- The minimum water flow rate is only guaranteed if the temperature difference of the heating medium does not exceed 10 K between water inlet and water outlet during heating.
- Only overpressure valves with an opening pressure of min. 0.4 – max. 2 bar may be used in the coolant circuit.
- The coolant liquid must contain at least 10% antifreeze all year round as corrosion protection.
- The cooling liquid must contain sufficient antifreeze for low temperatures.
- Before commissioning the heater or after changing the cooling liquid, the whole coolant circuit including heater must be vented free of bubbles according to the instructions issued by the vehicle manufacturer.
- Only top up with coolant approved by the vehicle manufacturer.

### 3 Installation

#### Connection to the cooling water circuit

##### Integrate the heater in the water feed pipe from the vehicle engine to the heat exchanger "inline connection"

Disconnect the water feed pipe from the vehicle engine to the vehicle heat exchanger. Connect up the heater with connection pieces and water hoses to the water feed pipe.

Route and connect a water hose from the pressure connection of the water pump to the water intake connection of the heater.

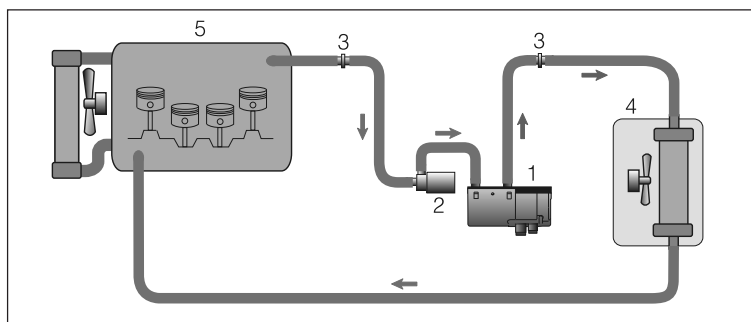

##### Integrate heater and water pump with non-return valve in the coolant circuit

Disconnect the water feed pipe from the vehicle engine to the vehicle heat exchanger and insert the non-return valve.

Connect the heater and the water pump to the non-return valve with the water hoses.

Route and connect a water hose from the pressure connection of the water pump to the water intake connection of the heater.

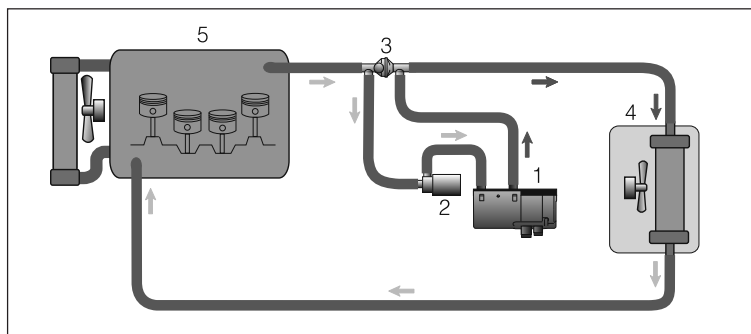

#### Heating characteristics

When the heater is switched on, the heat flows through the vehicle heat exchanger and the vehicle engine. Once the cooling water has reached a temperature of approx. 30 °C, depending on the selected fan setting the vehicle fan is switched on and the heat is also conveyed to the passenger compartment.

#### Heating characteristics

When the heater is switched on, the heat flows through the vehicle heat exchanger only to the vehicle engine. Once the cooling water has reached a temperature of approx. 30 °C, depending on the selected fan setting the vehicle fan is switched on and the heat is also conveyed to the passenger compartment.

#### Advantage compared to "inline connection" cooling water circuit

No loss of efficiency in the vehicle heating when the heater is switched off.

### 3 Installation

#### Connection to the cooling water circuit

##### Integrate heater and water pump with non-return valve, thermostat and T-piece in the coolant circuit

Disconnect the water feed pipe from the vehicle engine to the vehicle heat exchanger and insert the non-return valve.

Disconnect the water return pipe from the heat exchanger to the vehicle engine and insert the T-piece.

Connect the heater and the water pump to the thermostat, non-return valve and T-piece using water hoses, as shown in the diagram.

##### Heating characteristics

###### Small coolant circuit

Fast heating of the passenger compartment. Initially the heat produced by the heater is only conveyed to the heat exchanger up to a cooling water temperature of approx. 70 °C. This heats the passenger compartment up quickly.

###### Large cooling water circuit

If the cooling water temperature continues to increase, the thermostat slowly changes over to the large circuit (full change-over at approx. 75 °C). This heats the passenger compartment up and also allows for engine pre-heating.

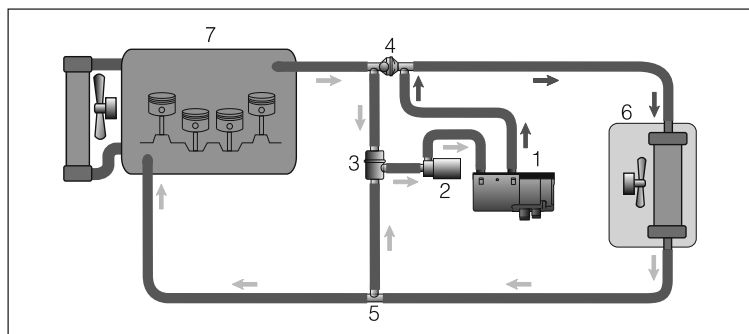

- ① Heater
- ② Water pump
- ③ Non-return valve
- ④ Thermostat
- ⑤ T-piece
- ⑥ Heat exchanger
- ⑦ Vehicle engine

#### Please note!

Thermostat, non-return valve and T-piece are contained in the convenient installation kit. Order no. see extra parts catalogue.

#### Thermostat functions

Cooling water temperature <70 °C – small coolant circuit:

Connection no. 1 – open to the heater

Connection no. 2 – open to the T-piece

Connection no. 3 – closed to the non-return valve

Cooling water temperature >75 °C – large coolant circuit:

Connection no. 1 – open (to the heater)

Connection no. 2 – closed (to the T-piece)

Connection no. 3 – open (to the non-return valve)

#### Please note!

Integrate the thermostat into the water circuit with connections ① ② and ③ as shown in the diagram.

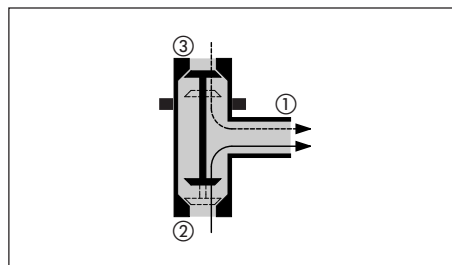

- ① Connection to the heater
- ② Connection to the T-piece
- ③ Connection to the non-return valve

### 3 Installation

#### Connection to the coolant circuit

##### Integrate heater and water pump with combination valve in the coolant circuit

###### Combination valve with 5 connections

If the water feed pipe and water return pipe from the vehicle engine to the heat exchanger are installed separately, the combination valve with 5 connections and an additional T-piece has to be used.

###### Combination valve with 6 connections

If the water feed pipe and water return pipe from the vehicle engine to the heat exchanger are installed in parallel, the combination valve with 6 connections (without T-piece) can be used.

#### Heating characteristics

##### Pre-heating mode – small coolant circuit

For the pre-heating mode, the heat is conveyed only to the vehicle heat exchanger so that the passenger compartment heats up quickly.

##### Extra heating function – partial circuit

When the vehicle engine starts up – low speed – part of the heat is conveyed to the vehicle engine. Shortens the warming up phase for the engine and heats the passenger compartment.

##### Extra heating function – large coolant circuit

At higher engine speeds (approx. 200 rpm), the heat is distributed evenly between the heat exchanger and the vehicle engine. Shortens the warming up phase even further and heats the passenger compartment.

#### Install combination valve with 5 connections

Disconnect the water feed pipe from the vehicle engine to the vehicle heat exchanger and insert the combination valve.

Disconnect the water return pipe from the heat exchanger to the vehicle engine and insert the T-piece.

Connect the heater to the combination valve with the water hoses, as shown in the drawing.

#### Install combination valve with 6 connections

Disconnect the water feed pipe and the water return pipe from the vehicle engine to the vehicle heat exchanger and insert the combination valve.

Connect the heater to the combination valve with the water hoses, as shown in the drawing.

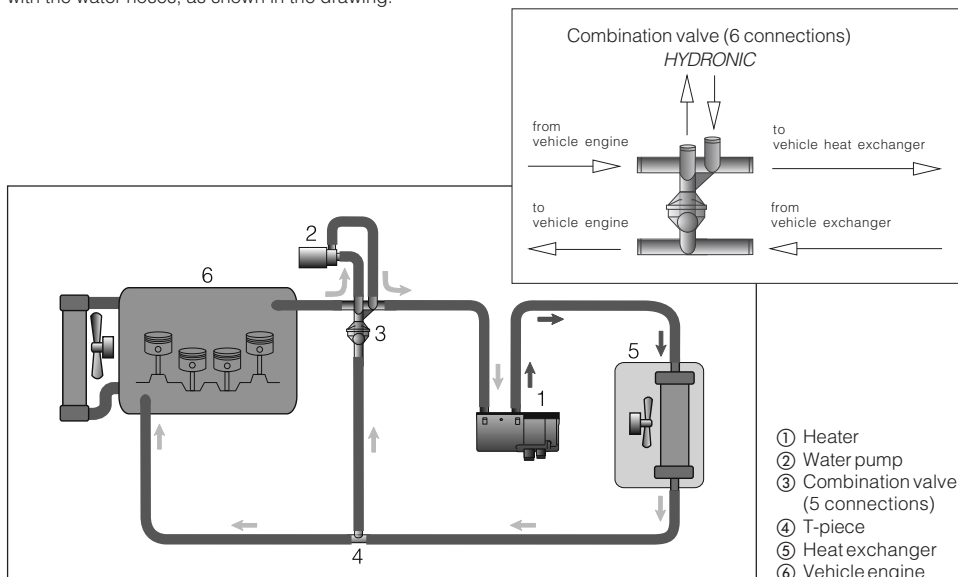



## 3 Installation

### Exhaust system

(Exhaust diagram see page 24)

#### Mounting the exhaust system

The scope of supply of the universal installation kit includes a flexible exhaust pipe, inner  $\varnothing$  24 mm, 1000 mm long and an exhaust silencer.

The flexible exhaust pipe can be shortened to 20 cm or lengthened to max. 2 m, depending on the installation conditions.

Fasten the exhaust silencer to a suitable position in the vehicle. Route the flexible exhaust pipe from the heater to the exhaust silencer and fasten with pipe clips. If necessary, also fasten the flexible exhaust pipe with pipe clips at suitable positions in the vehicle. Connect the exhaust end pipe to the exhaust silencer with an end sleeve and fasten with a pipe clip.



#### Caution!

#### Safety instructions!

The whole exhaust system gets very hot during and immediately after the heater has been working in the heating mode. This is why the exhaust system must be routed according to these installation instructions.

- The exhaust outlet must end in the open air.
- The exhaust pipe must not protrude beyond the lateral limits of the vehicle.
- Install the exhaust pipe sloping slightly downwards. If necessary, make a drain hole approx.  $\varnothing$  5 mm at the lowest point to drain off condensation.
- Important functional parts of the vehicle must not be impaired (keep sufficient clearance).
- Mount the exhaust pipe with sufficient clearance to heat-sensitive parts. Pay particular attention to fuel pipes (plastic or metal), electrical cables and brake hoses etc.!
- Exhaust pipes must be fastened safely (recommended clearance of 50 cm) to avoid damage from vibrations.
- Route the exhaust system so that the emitted fumes are not sucked in with the combustion air.
- The mouth of the exhaust pipe must not get clogged by dirt and snow.
- The mouth of the exhaust pipe must not point in the direction of travel.
- Always fasten the exhaust silencer to the vehicle.



#### Danger!

#### Risk of injuries and burns!

Every type of combustion produces high temperatures and toxic exhaust fumes. This is the reason why the exhaust system must be installed according to these instructions.

- Do not perform any work on the exhaust system while the heater is working.
- Before working on the exhaust system, first switch the heater off and wait until all parts have cooled down completely, wear safety gloves if necessary.
- Do not inhale exhaust fumes.

#### Please note!

- Comply with the regulations and safety instructions for this chapter on page 4 – 7.
- If a silencer is fitted, the exhaust end pipe must be much shorter than the flexible exhaust pipe between the heater and the exhaust silencer.

### 3 Installation

#### Combustion air system

##### Mounting the combustion air system

The heater is mounted in the engine compartment, as described in these instructions.

If the intake connection for combustion air is in a position where the combustion air can be expected to be no warmer than 25°C and whether neither splashed water nor dust / dirt are expected, then no combustion air hose is required.

Otherwise a flexible combustion hose must be mounted with an inner Ø 20 mm and up to 1.5 m long, to ensure that the intake of combustion air comes from an area which complies with the above conditions.

After completing all work, push an end sleeve over the intake silencer / flexible pipe.

#### Please note!

Comply with the regulations and safety instructions for this chapter on page 4 – 7.



**Caution!**

#### Safety instructions for the combustion air system

- The combustion air opening must be free at all times.
- Position the combustion air intake to be sure that exhaust fumes cannot be sucked in with the combustion air.
- Do not point the combustion air intake against the vehicle's airstream.
- The combustion air intake must not get clogged with dirt and snow.
- Install the combustion air intake system sloping slightly downwards. If necessary, make a drain hole approx. Ø 5 mm at the lowest point to drain off condensation.

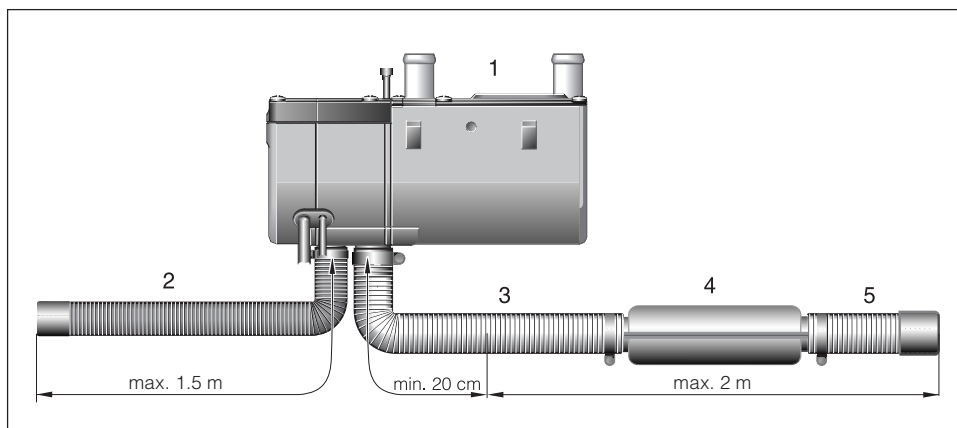

- ① Heater
- ② Combustion air pipe
- ③ Exhaust pipe
- ④ Exhaust silencer
- ⑤ Exhaust end pipe



## 3 Installation

### Fuel supply

#### Mounting the dosing pump, routing the fuel pipes and mounting the fuel tank

The following safety instructions must be observed when mounting the dosing pump, routing the fuel pipes and mounting the fuel tank.

Deviations from the instructions stated here are not allowed.

Failure to comply can result in malfunctions.



#### Danger!

#### Risk of fire, explosion, poisoning and injuries!

Caution when handling fuel.

- Switch off the vehicle engine and heater before refuelling and before working on the fuel supply.
- No naked lights when handling fuel.
- Do not smoke.
- Do not inhale fuel vapours.
- Avoid any contact with the skin.



#### Caution!

#### Safety instructions for routing the fuel pipes!

- Only use a sharp knife to cut off fuel hoses and pipes. Interfaces must not be crushed and must be free of burrs.
- The fuel pipe from the dosing pump to the heater should be routed at a continuous rise.
- Fuel pipes must be fastened safely to avoid any damage and/or noise production from vibrations (recommended clearance of approx. 50 cm).
- Fuel pipes must be protected from any mechanical

damage.

- Route the fuel pipes so that any distortion of the vehicle, engine movements etc. cannot have any lasting effect on the service life.
- Parts carrying fuel must be protected from interfering heat.
- Never route or fasten the fuel pipes to the heater or vehicle exhaust system. When the systems cross, always ensure there is a sufficient heat clearance. If necessary, install heat deflection plates.
- Dripping or evaporating fuel must never be allowed to collect on hot parts or ignite on electric systems.
- When connecting fuel pipes with a fuel hose, always mount the fuel pipes in a butt joint to prevent any bubbles from forming.

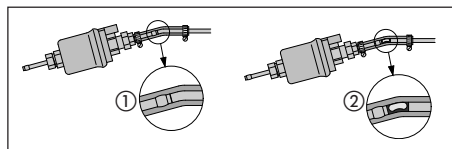

- ① Correct connection
- ② Incorrect connection – bubble formation

#### Safety instructions for fuel pipes and fuel tanks in buses and coaches

- In buses and coaches, fuel pipes and fuel tanks must not be routed through the passenger compartment or driver's cab.
- Fuel tanks in buses and coaches must be positioned in such a way that the exits are not in direct danger from a possible fire.

#### Please note!

Comply with the regulations and safety instructions for this chapter on page 4 – 7.

### 3 Installation

#### Fuel supply for petrol heaters

Fuel feed point with T-piece from the fuel supply line from the tank fitting to the vehicle engine

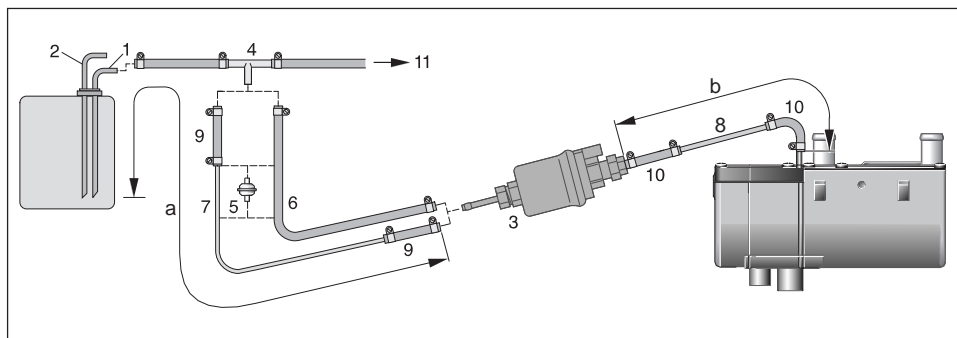

- ① Fuel feed pipe from tank connection – insert T-piece before the fuel pump in the fuel feed pipe.
- ② Fuel return pipe to the tank connection
- ③ Dosing pump
- ④ T-piece, 8-6-8
- ⑤ Fuel filter – only necessary for contaminated fuel.
- ⑥ Fuel hose, 5 x 3 (di = Ø 5 mm)
- ⑦ Fuel pipe, 6 x 2 (di = Ø 2 mm)
- ⑧ Fuel pipe, 4 x 1.25 (di = Ø 1.5 mm)
- ⑨ Fuel hose, 5 x 3 (di = Ø 5 mm), approx. 50 mm long
- ⑩ Fuel hose, 3.5 x 3 (di = Ø 3.5 mm), approx. 50 mm long
- ⑪ To the engine, mechanical fuel or injection pump.

#### Possible pipe lengths

**Intake side**  
a = max. 2 m

**Pressure side**  
b = max. 4 m for petrol  
b = max. 6 m for diesel

#### Please note!

Items ④ and ⑤ are not included in the scope of supply "installation kit".  
Order no. see extra parts catalogue.

#### Installation position of the T-piece

Use the installation positions shown in the diagram when inserting a T-piece.

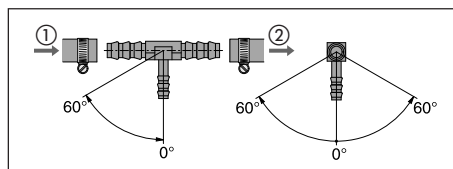

- ① Direction of flow from the fuel tank
- ② Direction of flow to the vehicle engine

### 3 Installation

#### Fuel supply for petrol heaters

#### Fuel feed point with tank connection – ascending pipe, integrated in the vehicle tank

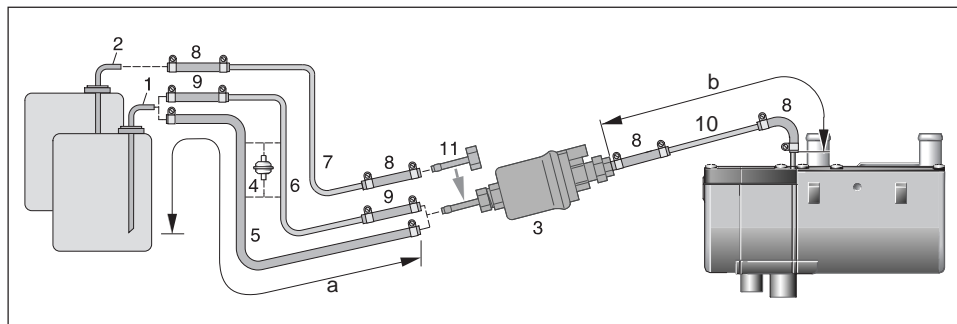

- ① Tank connection for metal tank –  
di = Ø 2 mm, da = Ø 6 mm
- ② Tank connection for tank fitting –  
di = Ø 2 mm, da = Ø 4 mm
- ③ Dosing pump
- ④ Fuel filter – only required for contaminated fuel.
- ⑤ Fuel hose, 5 x 3 (di = Ø 5 mm)
- ⑥ Fuel pipe, 6 x 2 (di = Ø 2 mm)
- ⑦ Fuel hose, 4 x 1 (di = Ø 2 mm)
- ⑧ Fuel hose, 3,5 x 3 (di = Ø 3,5 mm),  
approx. 50 mm long
- ⑨ Fuel hose, 5 x 3 (di = Ø 2 mm),  
approx. 50 mm long
- ⑩ Fuel pipe, 4 x 1,25 (di = Ø 1,5 mm)
- ⑪ Connection fitting, da = Ø 4 mm

#### Possible pipe lengths

##### Intake side

a = max. 2 m

##### Pressure side

b = max. 4 m for petrol  
b = max. 6 m for diesel

#### Please note!

Items ② ⑦ ⑪ are included in the "tank connection " kit.

#### Caution!

#### Safety instructions for the fuel supply!

- The fuel must not be conveyed by gravity or overpressure in the fuel tank.
- Withdrawal of fuel after the vehicle's fuel pump is not allowed.
- When the pressure in the fuel pipe is more than 0.2 bar to max. 2 bar, use a pressure reducer (order no. 22 1000 20 08 00) or separate tank connection.
- When the pressure in the fuel pipe is more than 2 bar or there is a non-return valve in the return pipe (in the tank), a separate tank connection must be used.
- When using a T-piece in a plastic pipe, always use support sleeves in the plastic. Connect the T-piece and the plastic pipe with corresponding fuel hoses and secure with hose clips.

### 3 Installation

#### Fuel supply

##### Installation position of the dosing pump

Always mount the dosing pump with the pressure side rising upwards. Every installation position over 15° is allowed, although an installation position between 15° and 35° is preferable.

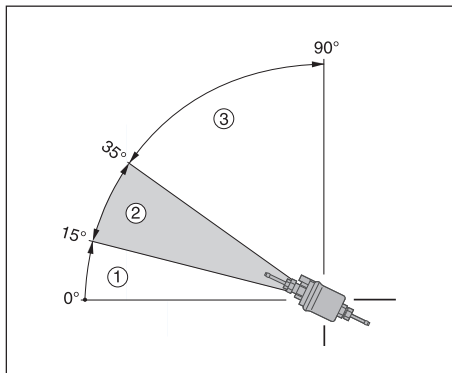

- ① Installation position between 0° and 15° is not allowed.
- ② Preferred installation position in range 15° to 35°.
- ③ Installation position in range 35° to 90° is allowed.

##### Possible suction and pressure height of the dosing pump

Pressure height from vehicle tank to dosing pump:  
a = max. 3000 mm

Intake height in pressure-less vehicle tank:  
b = max. 500 mm for petrol  
b = max. 1000 mm for diesel

Intake height in vehicle tanks with withdrawal by negative pressure (valve with 0.03 bar in tank cap):  
b = max. 150 mm for petrol  
b = max. 400 mm for diesel

Pressure height of the dosing pump to the heater:  
c = max. 2000 mm

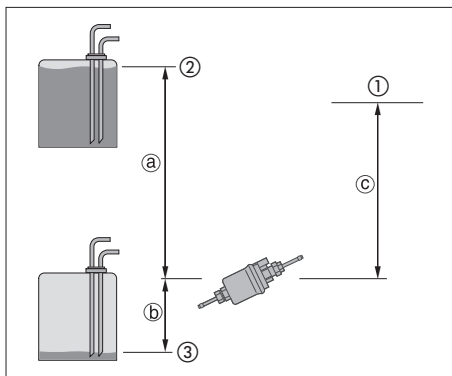

- ① Connection to heater
- ② Max. fuel level
- ③ Min. fuel level

#### Please note!

Check tank venting.



#### Caution!

##### Safety instructions for installing the dosing pump

- Always mount the dosing pipe with the pressure side rising upwards – minimum incline 15°.
- Protect the dosing pump and filter from intolerable heat, do not mount near to the silencers and exhaust pipes.



## 3 Installation

### Fuel supply

#### Fuel quality for petrol heaters

The heater can run on commercially available fuel as per DIN EN 228, as used in the vehicle tank.

#### Fuel quality for diesel heaters

The heater can run on commercially available fuel as per DIN EN 590, as used in the vehicle tank.

#### Fuel for special cases

In special cases (above 0 °C), the heater can also run on fuel oil EL or paraffin.

#### Fuel for low temperatures

Refineries and fuel service stations automatically adjust the fuel to normal winter temperatures (winter diesel). This means that difficulties are only to be expected for extreme drops in temperature, as also apply to the vehicle engine. Please also refer to the vehicle manual.

If the heater is run from a separate tank, please comply with the following rules:

For temperatures above 0 °C, any kind of diesel fuel as per DIN EN 590 can be used.

If no special diesel fuel is available for low temperatures, then paraffin or petrol should be mixed with the fuel according to the following table:

Temperature	Winterdiesel	Addition
0 °C to -25 °C	100 %	---
-25 °C to -40 °C	50 %*	50 % paraffin or petrol

\* or 100 % special cold diesel fuel (Arctic diesel)

#### Please note!

- Mixtures with used oil are not allowed!
- After refuelling with winter or cold diesel or the listed blends, the fuel pipes and the dosing pump must be filled with the new fuel by letting the heater run for 15 mins.!

#### Operation with biodiesel, D 5 WS – 24 volt (PME)

The heater is certified for running on biodiesel as per DIN V 51606 in free-flowing state (is reduced at temperatures under 0 °C).

## 4 Operation and function

### Operating instructions

The heater is operated by a control unit. The control unit is accompanied by detailed operating instructions which you will receive from the company installing the heater.

#### Please note!

The control units (e.g. mini timer, module timer) are supplied accompanied with operating instructions which will be handed over to you by the company installing the heater).

### Important instructions for operation

#### Safety checks before the start

After a longer interval in operations (after the summer months) the fuse must be put in position and / or the heater connected up to the battery. Check that all parts fit firmly (tighten screws where necessary). Check the fuel system visually for any leaks.

#### Before switching on

Before switching on or pre-programming the heater, adjust the heating control in the vehicle to "WARM" (maximum setting) and the fan to "slow" (low power consumption).

In vehicles with automatic heating, adjust the heating control to "MAX" and open the heating vents before switching the ignition off.

#### Pre-venting with change-over "heating / venting"

Pre-venting means the possibility of starting the vehicle fan directly from the heater preselection timer or, even more convenient, from the radio remote control TP4i or TP41i, thus bypassing the heating mode, so that the passenger compartment, which frequently heats up considerably in summer weather, can be ventilated briefly with fresh air (separate wiring).

#### Heating at high altitudes

When using the heater at high altitudes, please note:

- Heating at altitudes up to 1500 m:
  - Unlimited heating possible.
- Heating at altitudes over 1500 mm:
  - Heating is possible for short periods at this altitude (e.g. driving over a mountain pass or taking a break in a journey).
  - In the event of a lengthy stay, e.g. winter camping, it is necessary to adjust the fuel supply to the altitude, please contact a JE partner for further information.

#### Please note!

In diesel heaters, 12 volt, it is possible to install an altitude pump kit (Order No.: 24 0244 00 00 00), which allows the heater to be run at altitudes over 1500 m and up to 2750 m, even during a lengthy stay.

### Initial commissioning

The following points are to be checked by the company installing the heater during initial commissioning.

- After installation of the heater, the coolant circuit and the whole fuel supply system must be vented carefully. Comply with the instructions issued by the vehicle manufacturer.
- Open the coolant circuit before the trial run (set the temperature control to "OPEN").
- During the trial run of the heater, check all water and fuel connections for leaks and firm fitting.
- If the heater shows a fault during operation, find and eliminate the cause of the fault using a diagnosis unit.

### Description of functions

#### Switching on (pre-heating mode)

When the heater is switched on, the control lamp in the control unit (mini-timer, module timer) lights up. The water pump and the combustion air fan start up. After a certain programme with pre-rinsing and pre-heating, the glow plug and fuel dosing pump start the combustion procedure. Once a stable flame has formed, the glow plug switches off under time control.

#### Heating mode

Depending on heating requirements, the heater is adjusted in the following stages: LARGE – SMALL – OFF (Pause). The temperature limits are permanently programmed in the electronic controller. If the heating requirements in the "SMALL" stage are so small that the cooling water temperature reaches 85 °C, the heater goes into the pause mode. The heater continues to run on for approx. 130 seconds, then it switches off (Pause mode). The control lamp lights up and the water pump continues to run, even in the pause mode.

#### Please note!

To compensate for the low heating requirements coming from the vehicle engine, the heater can be operated as pre-heater or combined pre-heater and extra heater, depending on the settings (wiring see circuit diagram).



## 4 Operation and function

### Control and safety devices

The heater is equipped with the following control and safety devices.

- If the heater does not ignite within 90 seconds after starting the fuel pump, the start is repeated. If the heater still does not ignite after another 90 seconds, the heater is switched off. After an unacceptable number of failed start attempts, the controller is locked.\*
- If the flame goes off by itself during operation, the heater is restarted. If the heater does not ignite within 90 seconds after the fuel pump has started, or ignites and goes off again within 15 minutes, the heater is switched off. This status can be remedied by briefly switching off and on again.
- In the case of overheating (e.g. lack of water, poorly vented coolant circuit), the overheating sensor triggers, the fuel supply is interrupted and the heater switched off. Once the cause of overheating has been eliminated, the heater can be re-started by switching off and on again (on condition that the heater has cooled down again sufficiently, cooling water temperature <70 °C). After the heater has been switched off for overheating an unacceptable number of times, the controller is locked.\*
- The heater is switched off if the upper or lower voltage limit is reached.
- The heater does not start up when the glow plug is defect or when the electric lead to the dosing pump is interrupted.
- The speed of the fan motor is monitored continuously. If the fan motor does not start up, if it is blocked or if the speed falls below 40 % of the nominal speed, the heater is switched off after 60 sec.

\* The controller can be enabled again and the faults read off:

- using the module timer
- using the radio remote control TP5.

For other controls:

- by connecting up a diagnosis unit
- using the customer service program KD2000.

For operation and fault list, please refer to the enclosed operating instructions or the troubleshooting and repair instructions for the heater.

#### Please note!

Do not switch the heater off and on again more than twice.

#### Forced shut-down for ADR / ADR 99 operation

In vehicles for the transport of dangerous goods (e.g. tanker trucks), the heater must be switched off before the truck drives into a danger area (refinery, fuel service station, etc.)

Failure to comply results in the heater switching off automatically when:

- The vehicle engine is switched off.
- An additional unit is started up (e.g. auxiliary drive for unloading pump etc.).
- A vehicle door is opened (ADR 99 regulation, only in France).

The fan then runs on for max. 40 seconds.

#### Emergency shutdown – EMERGENCY OFF

If an emergency shutdown – EMERGENCY OFF – is necessary during operation, proceed as follows:

- Switch the heater off with the control or
- pull the fuse out or
- disconnect the heater from the battery.

## 5 Electrical system

### Heater wiring



#### Caution!

#### Safety instructions for wiring the heater!

The heater is to be connected up electrically according to the EMC directives. EMC can be affected if the heater is not connected up correctly. For this reason, comply with the following instructions:

- Ensure that the insulation of electrical cables is not damaged. Avoid: chafing, kinking, jamming or exposure to heat.
- In waterproof connectors, seal any connector chambers not in use with filler plugs to ensure they are dirt-proof and water-proof.
- Electrical connections and ground connections must be free of corrosion and firmly connected.
- Lubricate connections and ground connections outside the heater interior with contact grease.

#### Please note!

Comply with the following when wiring the heater and the control element:

- Electrical leads, switchgear and controllers must be arranged in the vehicle so that they can function perfectly under normal operating conditions (e.g. heat exposure, moisture etc.).
- The following cable cross sections are to be used between the battery and heater. This ensures that the max. tolerable voltage loss in the cables does not exceed 0.5 V for 12 V or 1 V for 24 V rated voltage.

Cable cross sections for a cable length of:

- up to 5 m (plus cable + minus cable) = cable cross section 4 mm<sup>2</sup>
- from 5 to 8 m (plus cable + minus cable) = cable cross section 6 mm<sup>2</sup>

- If the plus cable is to be connected to the fuse box (e.g. terminal 30), the vehicle cable from the battery to the fuse box must be included in rating the overall cable length and possibly re-dimensioned if necessary.
- Insulate unused cable ends.

### Parts list for the circuit diagrams

#### Parts list for the circuit diagrams

##### HYDRONIC – 12 volt

- 1.1 Burner engine
- 1.2 Glow plug
- 1.5 Overheating sensor
- 1.12 Flame sensor
- 1.13 Temperature sensor
- 2.1 Controller
- 2.2 Fuel dosing pump
- 2.5.7 Relay, vehicle fan
- 2.7 Main fuse 20 A
- 2.7.1 Fuse, actuation 5A
- 2.7.5 Fuse, vehicle fan 25 A
- 2.12 Water pump
- 5.1 Battery
- 5.1.2 Fuse block in the vehicle
- 5.9.1 Switch, vehicle fan
- 5.10 Vehicle fan
- a) Connect to D+ for extra heating option
- f) Disconnect line
- g) For petrol only
- h) For diesel only
- k) Switch (extra heating, e.g. outside temperature < 5 °C or summer / winter change-over)

Connectors and bush housings are shown from the cable inlet side.

#### Please note!

The circuit diagrams are printed at the end of this manual.





## 5 Electrical system

### Parts list for the circuit diagrams

#### Parts list for the circuit diagram control unit – 12 volt part 1 and part 2

- 2.15.9 Temperature sensor (outside temperature)
- 3.1.9 Change-over switch "heating / venting"
- 3.1.16 Button, radio remote control
- 3.2.9 Timer, module timer
- 2.3.12 Timer, mini 12 / 24 volt
- 3.2.14 Timer, mini lighting blue – 12 volt only
- 3.3.6 Radio remote control (receiver) TP41i
- b) Connect to terminal +15 when heating mode required > 2 h (with ignition switched on).
- c) Lighting terminal 58
- d) Pre-heating with vehicle fan (option)
- e) External button ON / OFF (option)
- i) Connection radio module receiver TP 4i

#### Cable colours

- rt = red
- bl = blue
- ws = white
- sw = black
- gn = green
- gr = grey
- ge = yellow
- vi = violet
- br = brown
- li = purple

#### Parts list for circuit diagram control units – 12 volt part 3.1 and 3.2

- 2.15.1 Temperature sensor (room temperature)
- 2.15.9 Temperature sensor (outside temperature)
- 3.1.16 Button, radio remote control
- 3.1.18 Button, *CALLTRONIC*
- 3.2.12 Timer, mini 12 / 24 volt
- 3.2.14 Timer, mini lighting blue – 12 volt only
- 3.3.7 Radio remote control TP5
- 3.3.8 Remote control, *CALLTRONIC*
- 3.8.3 Antenna
- 3.9.1 Diagnosis unit JE diagnosis
- z) Terminal 58 (lighting)

Connectors and bush housings are shown from the cable inlet side.

#### **Please note!**

The circuit diagrams are printed at the end of this manual.

## 5 Electrical system

### Parts list for the circuit diagrams

#### Parts list for circuit diagram *HYDRONIC* – 24 volt and circuit diagram controls – 24 volt

- 1.1 Burner engine
- 1.2 Glow plug
- 1.5 Overheating sensor
- 1.12 Flame sensor
- 1.13 Temperature sensor
  
- 2.1 Controller
- 2.2 Fuel dosing pump
- 2.5.7 Relay, vehicle fan
- 2.7 Main fuse 20 A
- 2.7.1 Fuse, actuation 5A
- 2.7.5 Fuse, vehicle fan 25 A
- 2.12 Water pump
- 2.15.9 Sensor, outside temperature
  
- 3.1.16 Button, radio remote control
- 3.2.9 Timer, module timer
- 3.2.12 Timer, mini 12 / 24 volt
- 3.3.7 Radio remote control TP 5
- 3.8.3 Antenna
  
- 5.1 Battery
- 5.1.2 Fuse block in the vehicle
- 5.9.1 Switch, vehicle fan
- 5.10 Vehicle fan
  
- b) Connect to terminal + 15
- c) Lighting, terminal 58
- e) External button ON / OFF (option)
- f) Disconnect line
- i) Connection radio module receiver TP 4i

Connectors and bush housings are shown from the cable inlet side.

#### Please note!

- The circuit diagrams are printed at the end of this manual.
- The dotted lines are to be routed and connected in addition. Before doing so, disconnect the cable hardness at the points marked f). The cable seals and receptacles for connector B1 and the fan relay are included in the installation kit.  
The vehicle fan starts up as soon as the heater has started.

#### Parts list for circuit diagram *HYDRONIC* – 24 volt and circuit diagram controls – 24 volt ADR / ADR99

- 1.1 Burner engine
- 1.2 Glow plug
- 1.5 Overheating sensor
- 1.12 Flame sensor
- 1.13 Temperature sensor
- 2.1 Controller
- 2.2 Fuel dosing pump
- 2.5.7 Relay, vehicle fan
- 2.7 Main fuse 15 A
- 2.7.1 Fuse, actuation 5A
- 2.7.5 Fuse, vehicle fan 25 A
- 2.12 Water pump
- 3.2.9 Timer, module timer, ADR / ADR99
- 5.1 Battery
- 5.1.2 Fuse block in the vehicle
- 5.2.1 Battery main switch m)  
(operation controlled e.g. by ignition lock)
- 5.2.2 Battery disconnecter (EMERGENCY OFF function for ADR / ADR99) d)
- 5.3 Auxiliary drive (HA+)
- 5.3.1 Auxiliary drive switch
- 5.5 Generator terminal (D+)
- 5.9.1 Switch, vehicle fan
- 5.10 Vehicle fan
  
- b) Connect to terminal + 15
- c) Lighting, terminal 58
- f) Disconnect line
- g) Insolate and tie back the line
- m) When using only one switching element for nos. 5.2.1 and 5.2.2, ensure that the switch always triggers immediately on activating the function "Trigger the battery disconnecting switch" (EMERGENCY OFF function for ADR ADR99 etc.) (regardless of the heater status) and disconnects all heater circuits from the battery.

#### Cable colours

- |            |             |
|------------|-------------|
| rt = red   | gr = grey   |
| bl = blue  | ge = yellow |
| ws = white | vi = violet |
| sw = black | br = brown  |
| gn = green | li = purple |



### In case of faults, please check the following points

- If the heater does not start after being switched on:
  - Switch the heater off and on again.
- If the heater still does not start, check whether:
  - There is fuel in the tank?
  - The fuses are OK?
  - The electrical cables, connections etc. are OK?
  - Anything is clogging the combustion air supply or exhaust system?

### Troubleshooting

If the heater remains faulty even after these points have been checked, or another malfunction occurs in your heater, please contact:

- For installation ex works, your contract workshop.
- For subsequent installation, the workshop who installed your heater.

#### **Please note!**

Please note that warranty claims can become void if the heater is changed by a third party or by this installation of third party parts.

### Maintenance instructions

- Switch the heater off once a month for about 10 minutes, even outside the heating period.
- Before the heating period starts, the heater should undergo a trial run.  
If persistent extreme smoke develops, unusual burning noises or a clear fuel smell can be perceived or if electric / electronic parts heat up, the heater must be switched off and put out of service by removing the fuse.  
In this case, the heater should not be started up again until it has been checked by qualified staff who have been trained on Eberspächer heaters.
- Check the openings of the combustion air supply and exhaust system after longer standstill periods, clean if necessary!

### Initial commissioning

The following points are to be checked by the company installing the heater during initial commissioning.

- After installation of the heater, the coolant circuit and the whole fuel supply system must be vented carefully. Comply with the instructions issued by the vehicle manufacturer.
- Open the coolant circuit before the trial run (set the temperature control to "OPEN").
- During the trial run of the heater, check all water and fuel connections for leaks and firm fitting.
- If the heater shows a fault during operation, find and eliminate the cause of the fault using a diagnosis unit.

### Service

If you have any technical queries or problems with your pre-heater, dial the following service phone number:

Hotline  
Phone 00 49 (0)800 / 12 34 300

Fax hotline  
Fax 00 49 (0)1805 / 26 26 24

## 7 Environment

---

### Certification

The high quality of Eberspächer's products is the key to our success.

To guarantee this quality, we have organised all work processes in the company along the lines of quality management (QM).

Even so, we still pursue a large number of activities for continuous improvement of product quality in order to keep pace with the similarly constantly growing requirements made by our customers.

All the steps necessary for quality assurance are stipulated in international standards.

This quality is to be considered in a total sense.

It affects products, procedures and customer/supplier relationships.

Officially approved public experts assess the system and the corresponding certification company awards a certificate.

Eberspächer has already qualified for the following standards:

### Quality management as per

**DIN EN ISO 9001:2000 and ISO/TS 16949:1999**

### Environment management system as per

**DIN EN ISO 14001:1996**

### Disposal

#### Disposal of materials

Old devices, defect components and packaging material can all be separated and sorted into pure-grade fractions so that all parts can be disposed of as required in an environment-friendly manner or recycled where applicable.

Electric motors, controllers and sensors (e.g. temperature sensors) are deemed to be "electronic scrap".

#### Dismantling the heater

The heater is dismantled according to the repair stages in the current troubleshooting / repair instructions.

#### Packaging

The packaging of the heater can be kept in case it has to be sent back.

### EU Declaration of Conformity

With regard to the following products

#### Heater type *HYDRONIC*

we herewith confirm that it conforms with the prime safety requirements stipulated in the directives of the EU Council for harmonisation of the legal regulations of the member states with regard to electromagnetic compatibility (89 / 336 / EEC).

This declaration applies to all heaters produced according to the production drawings *HYDRONIC* which are an integral part of this declaration.

The following standards/directives have been used to assess the product with regard to electromagnetic compatibility:

- EN 50081 – 1 Basic form interference emission.
- EN 50082 – 1 Basic form interference resistance.
- 72 / 245 / EEC – Modification status 95 / 54 / EU interference suppression in motor vehicles.



## 8 Lists

### List of key words A – Z

<b>Keyword</b>	<b>Page</b>		
<b>A</b>		<b>H</b>	
Accident prevention .....	7	Heating operation .....	31
Altitude .....	31	Heat flow .....	12, 13
Ambient temperature .....	12, 13	Hotline .....	35
Arrangement of the heater .....	5		
<b>B</b>		<b>I</b>	
Bubble formation .....	24	Information .....	4
<b>C</b>		Installation location .....	15
Cable colours .....	34	Installation positions .....	16
Cable harnesses .....	8, 10	Instructions .....	4, 5
Cable lengths .....	25, 26, 28, 29	Installation .....	15, 16
Certification .....	36	Introduction .....	2
Circuit diagrams (at the end of the manual)		Initial commissioning .....	31
Cooling water circuit .....	18 – 21	Interference suppression class .....	12, 13
Combination valve .....	21		
Combustion air system .....	23	<b>M</b>	
Contents .....	2	Main dimensions .....	14
Concept of this manual .....	3	Materials .....	36
Control in heating mode .....	31	Maintenance .....	35
Controls .....	32		
Connection to the coolant circuit .....	18 – 21	<b>N</b>	
<b>D</b>		Nameplate .....	17
Description of functions .....	31	Noise emissions .....	12, 13
Declaration of conformity .....	36		
Disposal .....	36	<b>O</b>	
Dosing pump .....	27	Operation .....	31
<b>E</b>		Operating instructions .....	31
Electronic components .....	33, 34		
Emergency shut-down .....	32	<b>P</b>	
Emergency off .....	32	Picture symbols .....	4
Environment .....	36	Power consumption .....	12, 13
EU Declaration of Conformity .....	36	Presentations .....	4
Exhaust .....	22	Pressure side .....	25 – 27
Exhaust system .....	5, 22, 23	Protection .....	12, 13
Extra parts .....	8, 10	Proper use .....	4
		Purpose .....	4
<b>F</b>			
Fastening .....	16	<b>R</b>	
Faults .....	35	Rated voltage .....	12, 13
Fire resistance .....	12, 13	Regulations .....	5, 6
Forced shut-down .....	32		
Fuel .....	24 – 30	<b>S</b>	
Fuel withdrawal .....	24 – 29	Safeguards .....	32
Fuel system .....	24 – 30	Scope of supply .....	8 – 11
Fuel quality .....	27, 30	Special text structure .....	4
Fuel supply .....	24 – 30	Statutory regulations .....	5, 6
Fuel feed .....	5	Storage temperature .....	12, 13
		Starting procedure .....	31
<b>Keyword</b>	<b>Page</b>	Suction height .....	27
		Switching on .....	31

## 8 Lists

---

### List of key words A – Z

<b>Keyword</b>	<b>Page</b>
<b>T</b>	
Test symbol .....	5
Text structure .....	4
Technical data .....	12, 13
Troubleshooting .....	35
T-piece .....	25, 28
<b>V</b>	
Voltage .....	12, 13
Voltage limit .....	12, 13
<b>W</b>	
Wiring .....	33

### List of abbreviations

#### **ADR**

European agreement about the international transport of dangerous goods on the road.

#### **ADR99**

Dangerous goods regulations for France.

#### **EC type approval**

Permit awarded by the Federal Vehicle Office for the production of a heater for installation in motorised vehicles.

#### **EMC directive**

Electromagnetic compatibility.

#### **JE partner**

J. Eberspächer partner.

#### **PME**

Biodiesel as per DIN V 51606.



Circuit diagram **HYDRONIC** – 12 volt

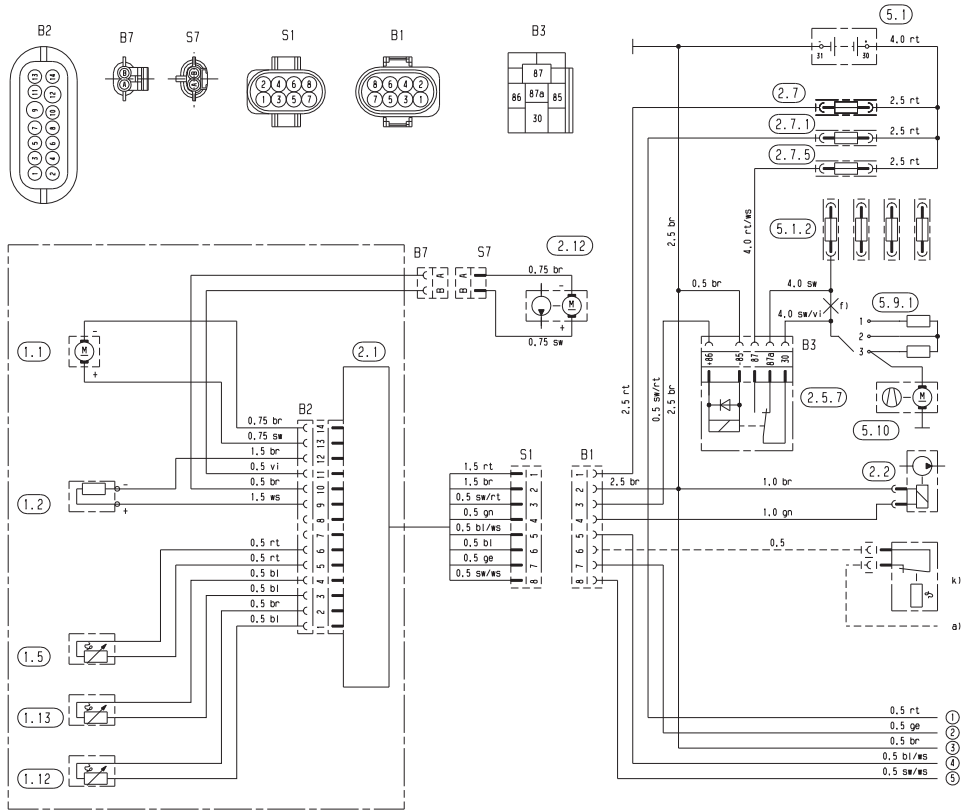

20 1777 00 96 01 B

**Circuit diagram for control unit 12 volt – part 1**

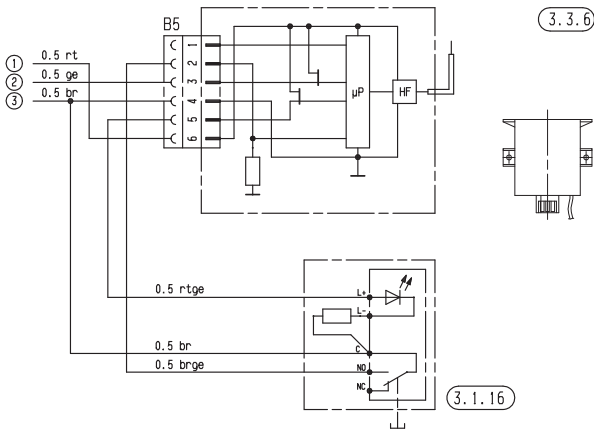
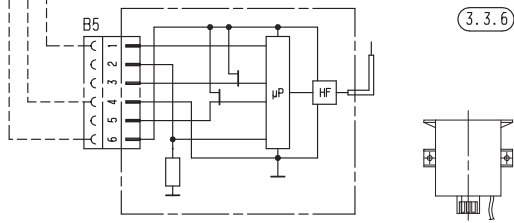
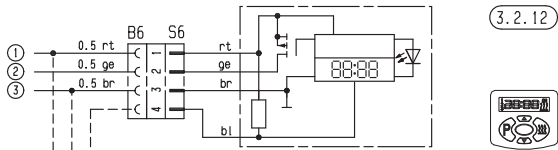
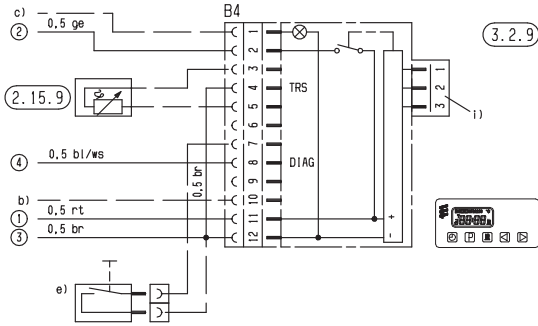

3.1.16



### Circuit diagram for control unit 12 volt – part 2

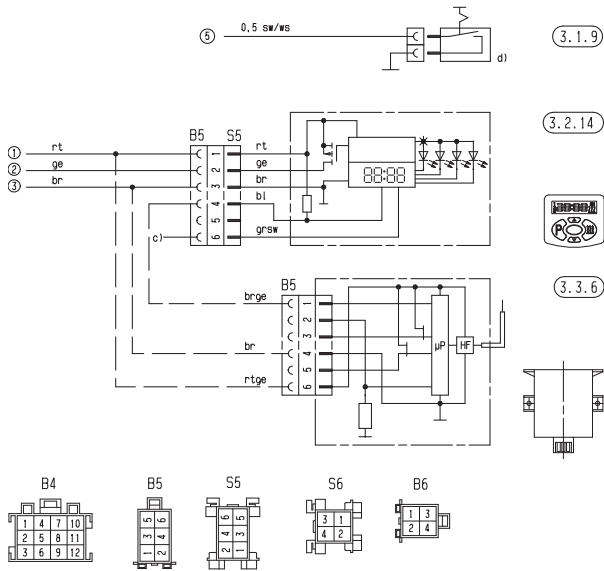

### Circuit diagram for control unit 12 volt – part 3.1

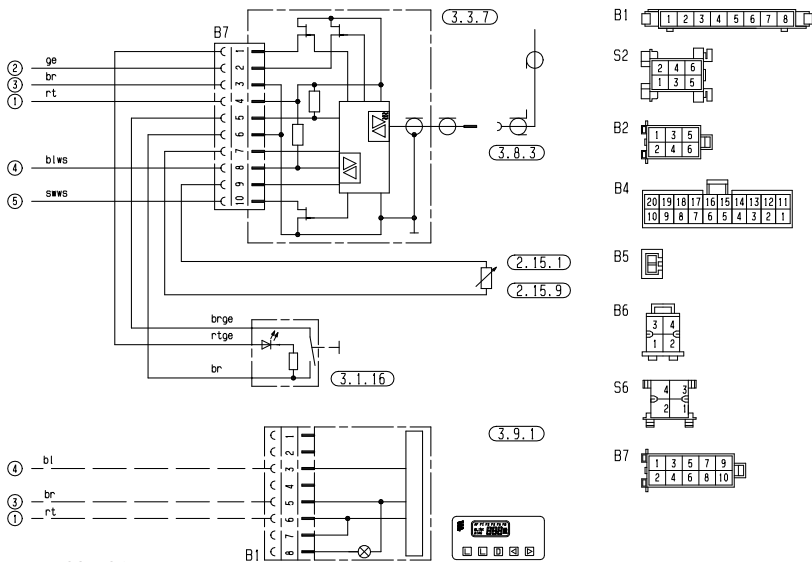

Circuit diagram for control unit 12 Volt – part 3.2

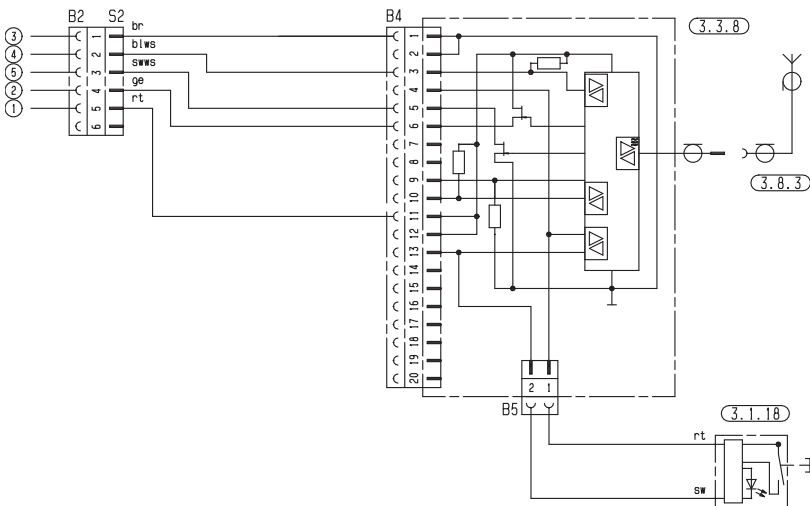
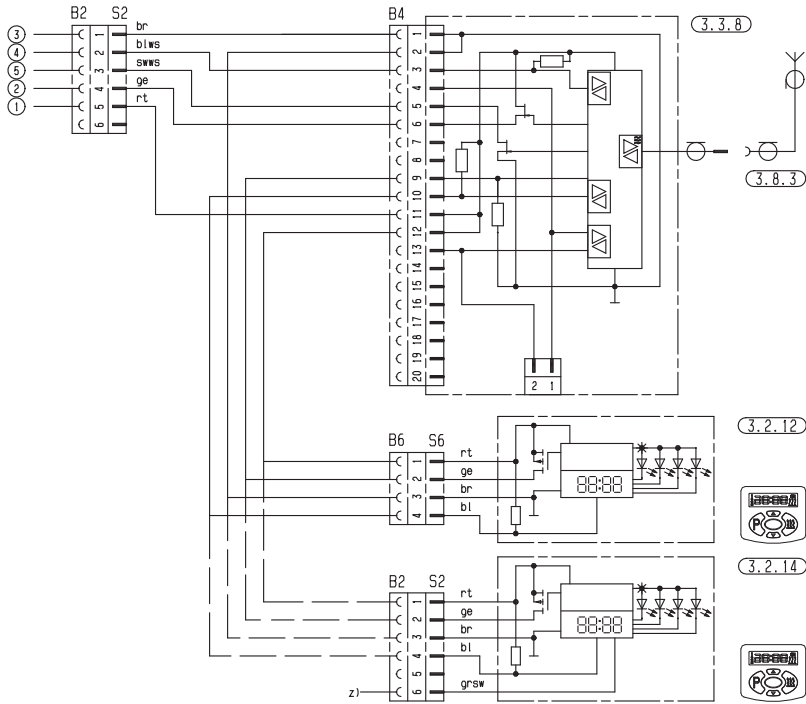



# Circuit diagram *HYDRONIC* – 24 volt

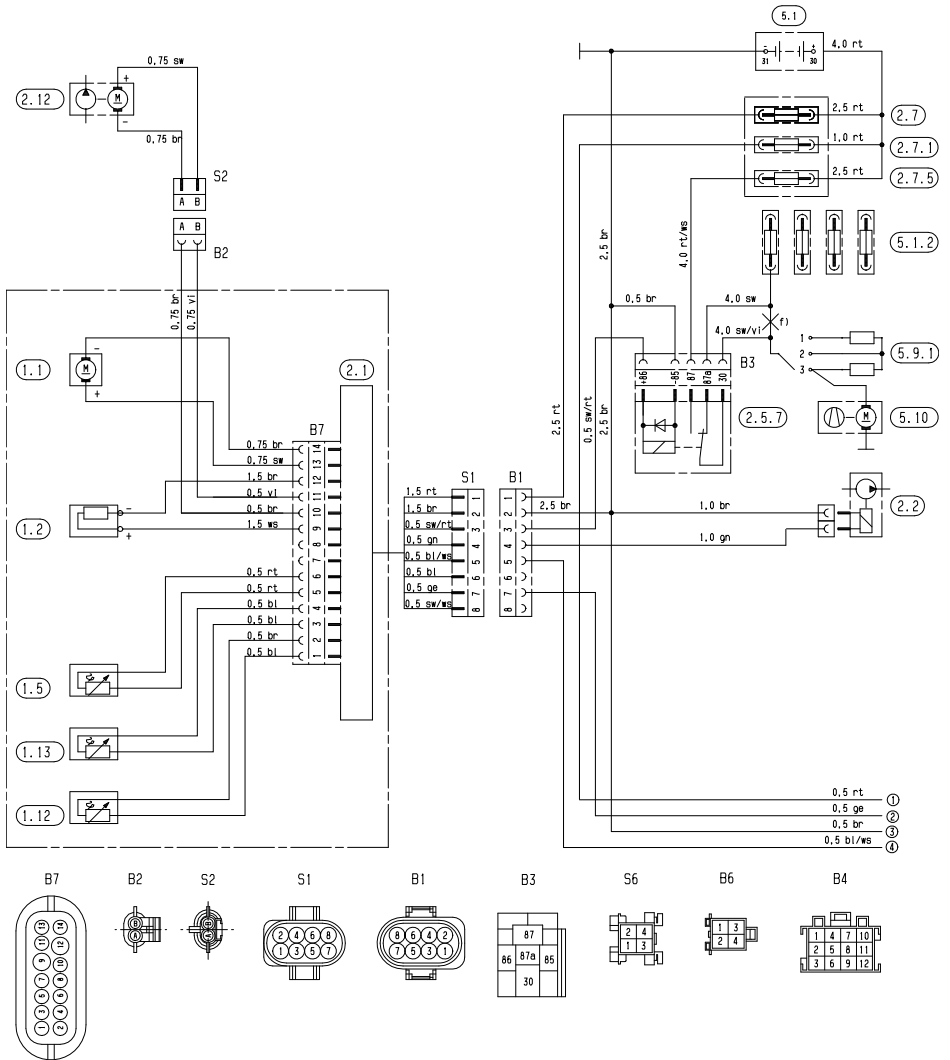

25 2147 00 96 01 D

**Circuit diagram for control unit – 24 volt**

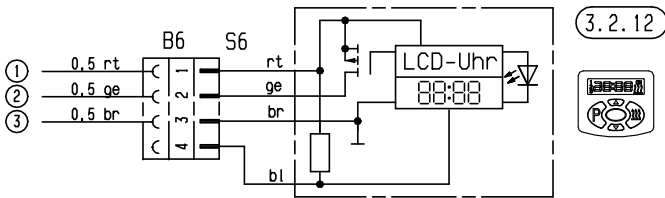
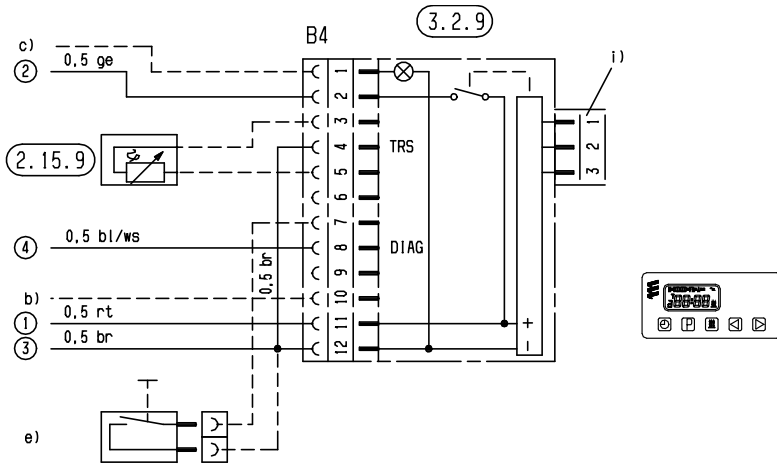

25 2147 00 96 01 D



Circuit diagram **HYDRONIC** – 24 volt ADR / ADR99

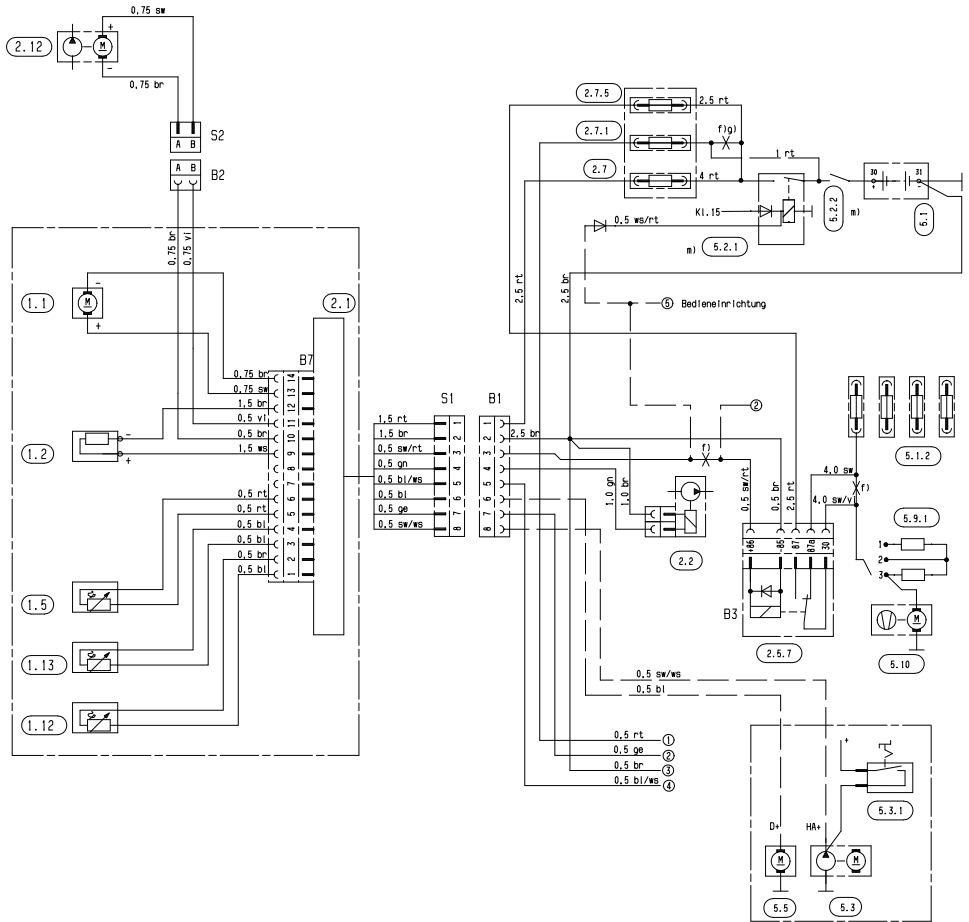

25 2147 00 97 01 D

Circuit diagram for control unit – 24 volt ADR / ADR99

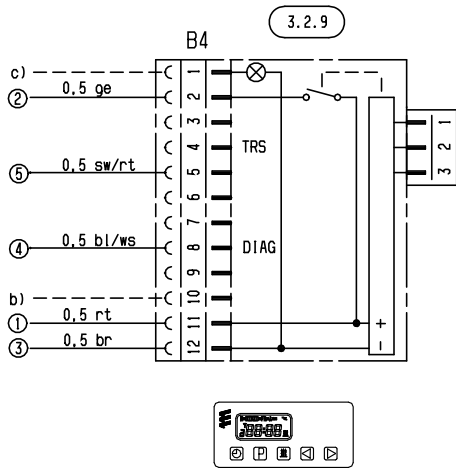

25 2147 00 97 01 D



**[www.eberspaecher.com](http://www.eberspaecher.com)**

J. Eberspächer  
GmbH & Co. KG  
Eberspächerstr. 24  
D - 73730 Esslingen  
Telefon 0711 939 - 00  
Telefax 0711 939 - 0643  
[info@eberspaecher.com](mailto:info@eberspaecher.com)



**Eberspächer**