

iMovR Cascade & Energize

INSTALLATION MANUAL

Cascade Standing Desk™



Energize Standing Desk™



STEP 1

BEFORE YOU BEGIN

Congratulations on purchasing an iMovR Cascade or Energize Standing Desk! Use this guide or our [installation video](#) to assemble your new desk. If you have any questions during the process, please contact our customer care team—we'll be happy to help.

TABLE OF CONTENTS

- Before You Begin 2-3
- Assembly Instructions 4-11
- Controller Instructions 12-13
- Trouble Shooting 14
- Final Touches..... 14
- Maintenance 15
- Specifications 15
- Warranty 16
- Contact Information 16

SAVE THESE INSTRUCTIONS – THINK SAFETY!

TOOLS



Allen wrench (Included)



Phillips head screwdriver (not included)



Optional power drill with phillips head (not included)

GET READY









Use these charts to make sure all the contents of your desk are present.

DESK ASSEMBLY PARTS











#	Part name	Picture	Qty
1	Tabletop		1
2	Leg		2
3	23-Inch Back Crossbar		2
4	21-Inch Front Crossbar		2
5	M8 Hex Screw		16
6	Plastic Cover Plug		4
7	Foot		2
8	Leveling Pad (come attached to feet)		4
9	M4.5 20mm Wood Screw - or - M5 20mm Machine Screw		21

Note: Depending on tabletop, you will receive EITHER Wood Screws OR Machine Screws

DESK ASSEMBLY PARTS

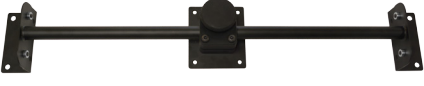
#	Part name	Picture	Qty
10	26-Inch Center Crossbar		1
11a	Cord Tray		1
11b	M4.5 20mm Wood Screw		2
12a	Control Unit		1
12b	M3.5 20mm Wood Screw		2
13a	Handset		1
13b	M4 15mm Wood Screw		2
14	Leg Motor Cable		2
15	Power Supply		1

KEYBOARD TRAY ASSEMBLY PARTS (included with Cascade desks only)

#	Part name	Picture	Qty
16	Keyboard Platform		1
17	Keyboard Platform Support		2
18a	#10 1-1/4" Flat Head Phillips Screw		6
18b	#10 5/8" Pan Head Phillips Screw		7
18c	M5 20mm Pan Head Machine Screw		8
18d	Spacer		6
19	Keyboard Platform Mounting Assembly		1
20	Keyboard Fence		1
21a	Carriage Bolt		2
21b	Rubber Bumpers		2

ASSEMBLY INSTRUCTIONS

STEP 2

PREPARE YOUR WORK AREA

Clear your working area of any materials that might scratch or damage the tabletop.

Place the tabletop upside-down on a soft surface such as carpet or a blanket.

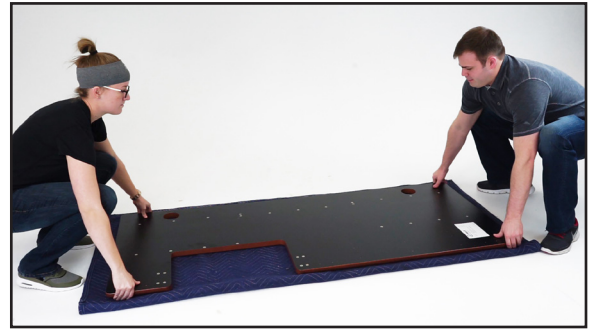

STEP 3

OPEN BASE BOX & REMOVE ALL ITEMS

Remove the base parts from the box and arrange the contents near your assembly area. Check to make sure you have all the necessary parts.



STEP 4

ATTACH CROSSBARS TO LEGS

1. Position Legs (Part #2) facing each other, as shown in figure 1 below.
2. Attach 23-Inch Back Crossbars (Part #3) to legs using 2 M8 Hex Screws (Part #5).
3. Attach 21-Inch Front Crossbars (Part #4) to legs using 2 M8 Hex Screws (Part #5).
4. Place Plastic Cover Plugs (Part #6) on outside edges of legs. Press firmly to secure.

Step 4 Complete

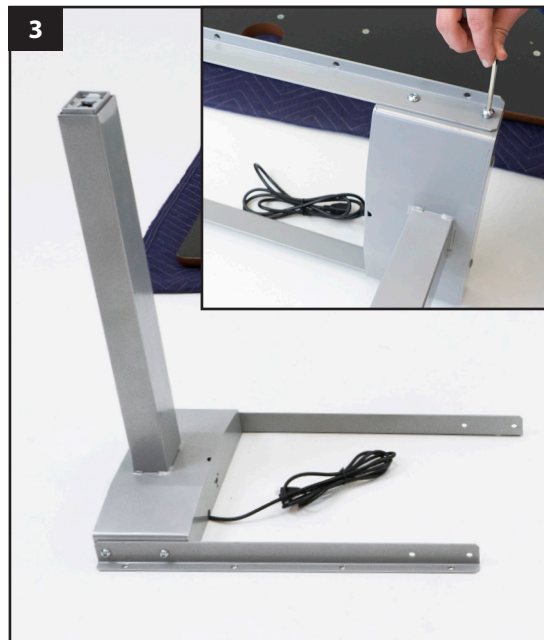
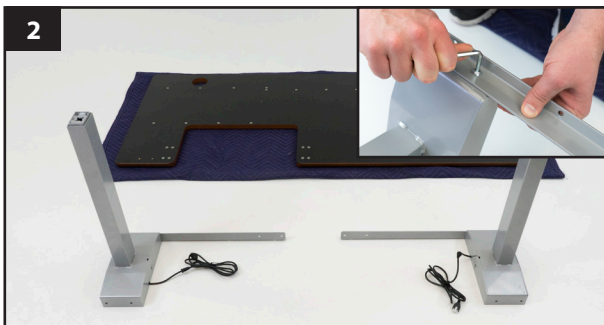
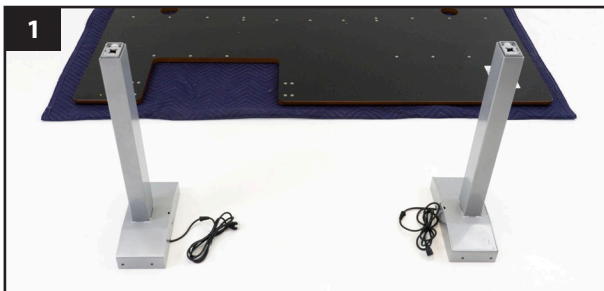
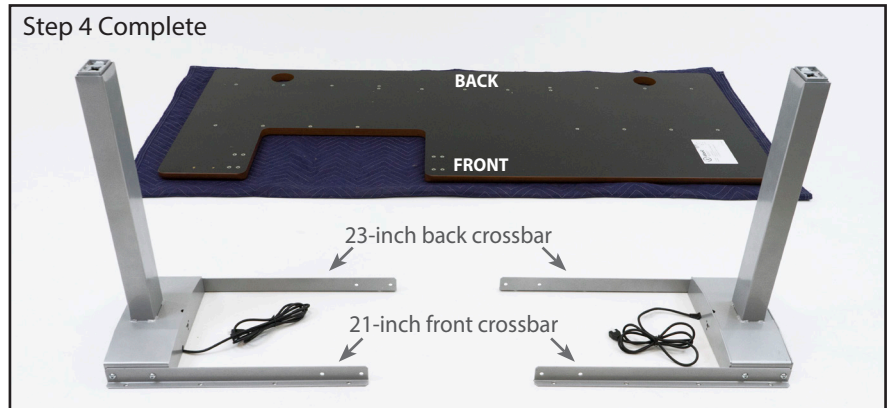

ATTACH FEET TO LEGS

1. Attach Feet (Part #7) to Legs using 4 M8 Hex Screws (Part #5). Ensure Feet face correct direction (short ends towards back of desk).
2. Hand turn Leveling Pads (Part #8) tightly.

Note: These pads help level desk in event of an uneven floor surface; they can be easily re-adjusted after assembly.

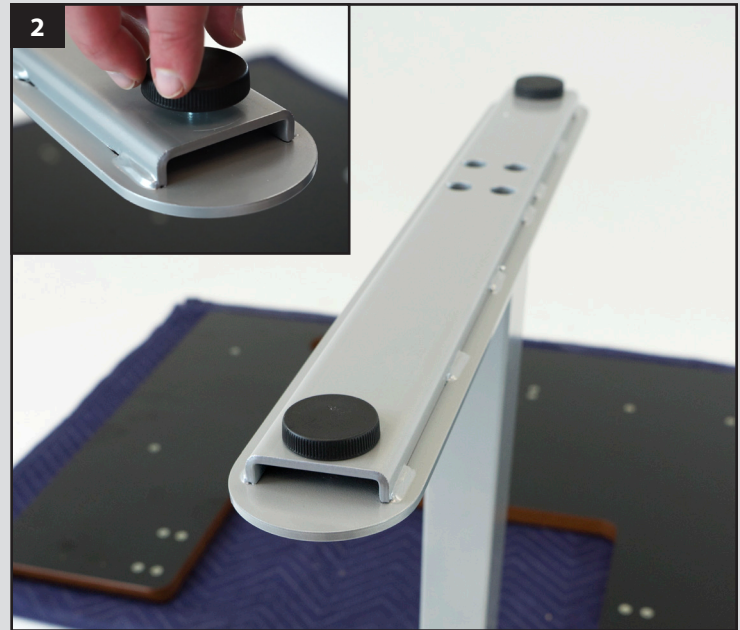
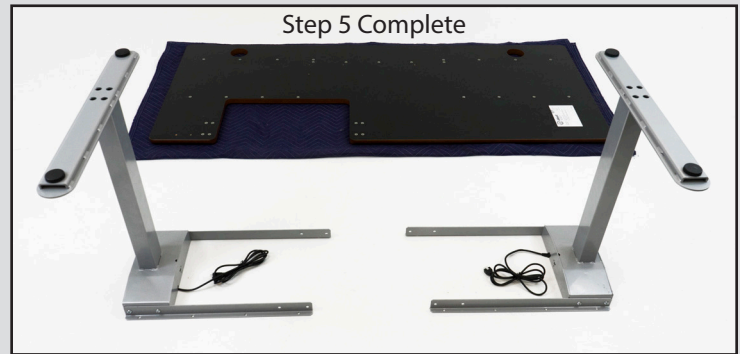
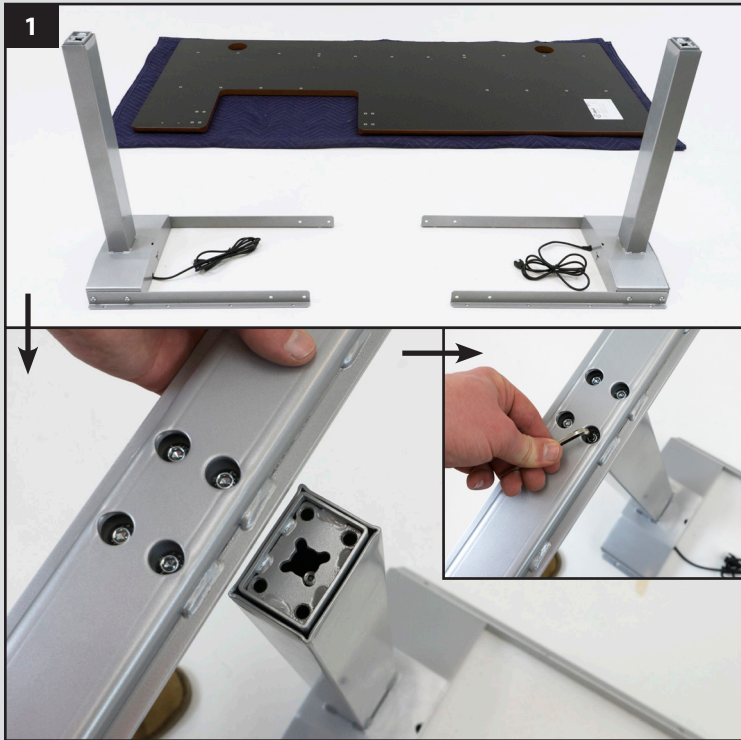

ATTACH LEGS TO TABLETOP

1. Place assembled legs on tabletop. Align with holes on tabletop.

CAUTION! Do not trap leg motor cables underneath desk.

2. Attach assembled legs using 16 M4.5 20mm Wood Screws or M5 20mm Machine Screws (Part #9).

Note: Slim Tops (3/4" width) come with Wood Screws while Select Tops (1 1/8" width) come with Machine Screws.



STEP 7

ATTACH CENTER CROSSBAR TO TABLETOP

1. Align 26-Inch Center Crossbar (Part #10) with holes on tabletop. Center Crossbar should rest flush against 23-Inch Back Crossbars.
2. Attach Center Crossbar using 4 M4.5 20mm Wood Screws or M5 20mm Machine Screws (Part #9).



STEP 8

ATTACH CORD TRAY TO TABLETOP

1. Align Cord Tray (Part #11a) with holes in front of Center Crossbar. Cord Tray should open towards front of desk.
2. Attach Cord Tray using 2 M4.5 20mm (Part #11b).



STEP 9

INSTALL CONTROL UNIT

1. Place Control Unit (Part #12a) between crossbars. Align with 2 holes to left of Cord Tray.
2. Attach using 2 M3.5 20mm Wood Screws (Part #12b).



STEP 10

INSTALL HANDSET (UP/DOWN CONTROLLER)

1. Align Handset (Part #13a) with 2 holes towards front edge of tabletop. Sets of holes are on left and right sides. Choose your preferred location.

2. Attach using 2 M4 15mm Wood Screws (Part #13b).
(See Controller Instructions below for operating the Handset.)



STEP 11

PLUG IN CORDS TO CONTROL UNIT

1. Plug Leg Motor Cables (Part #14) into 6-pin sockets on Control Unit.

2. Plug Handset into socket on reverse side of Control Unit.

3. Plug Power Supply (Part #15) into socket next to 6-pin sockets on Control Unit.

See "Final Touches" on page 14 for tips on managing your cords.



STEP 12

INSTALL OPTIONAL KEYBOARD TRAY

Make use of the pre-drilled holes under your tabletop by installing an ergonomic keyboard tray!

If you're looking for a way to boost your wrist and arm ergonomics while saving desk space, you may want to try our best-in-class iMovR Stowaway Keyboard Tray. Tilting to an industry-leading -20° for enhanced wrist ergonomics, it also comes with a fully-articulating mouse platform for minimizing lateral arm movement, and conveniently stows under your desk for when it's not in use. Backed by our lifetime warranty.

For details, visit:

iMovR.com/thermodesk-retractable-keyboard-tray.html



STEP 13

If you've purchased a **Cascade** desk, now is time to **INSTALL THE STEADYTYPE™ TILTING KEYBOARD PLATFORM.**

If you've purchased an **Energize** desk, **SKIP TO STEP 14.**

STEP 13.1

ASSEMBLE KEYBOARD PLATFORM

1. There are 2 options for mounting your Keyboard Platform. Choose **option a** – for standard mounting position. Choose **option b** – if you plan to stand often, and want your keyboard closer to height of desk surface. (See photos to the right.)

a. Align 2 Keyboard Platform Supports (Part #17) with **front set** of triangular hole patterns on left and right sides of Keyboard Platform (Part #16); include 3 Spacers (Part # 18d) underneath each Platform Support.

b. Align 2 Keyboard Platform Supports (Part #17) with **back set** of triangular hole patterns on left and right sides of Keyboard Platform (Part #16); include 3 Spacers (Part # 18d) underneath each Platform Support.

CAUTION! Do not place Spacers between screw heads and Platform Supports. Ensure Spacers rest against underside of Keyboard Platform.

2. Fasten Keyboard Platform Supports using 3 #10 1-1/4" Flat Head Phillips Screws (Part #18a).

3. Position Keyboard Platform Mounting Assembly (Part #19) by matching square mounting plate to triangular pattern of recessed holes in center of Keyboard Platform.

4. Attach using 4 #10 5/8" Pan Head Phillips Screws (Part #18b).

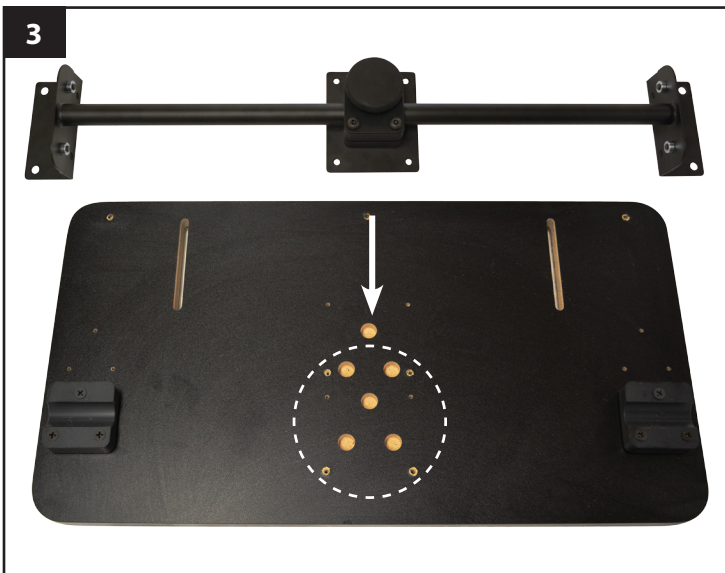
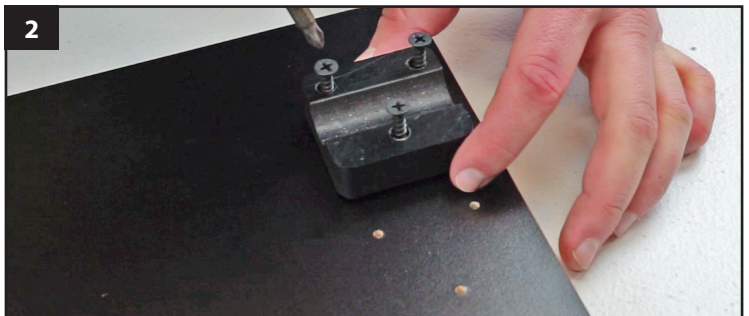
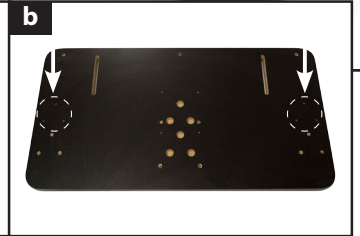

STEP 13.2

ATTACH KEYBOARD PLATFORM

1. Align Keyboard Tray Mounting Assembly (Part #19) with 4 insert nuts on both sides of SteadyType desk cutout.
2. Attach using 8 M5 20mm Pan Head Machine Screws (Part #18c).

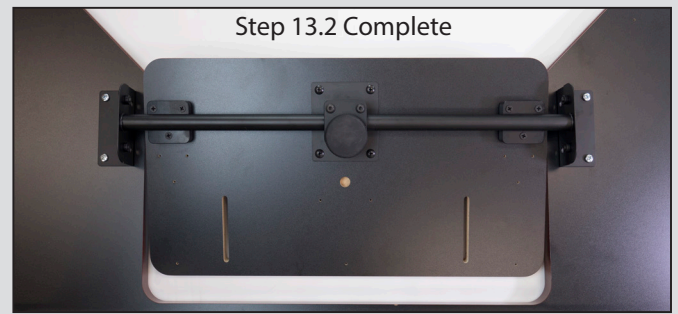
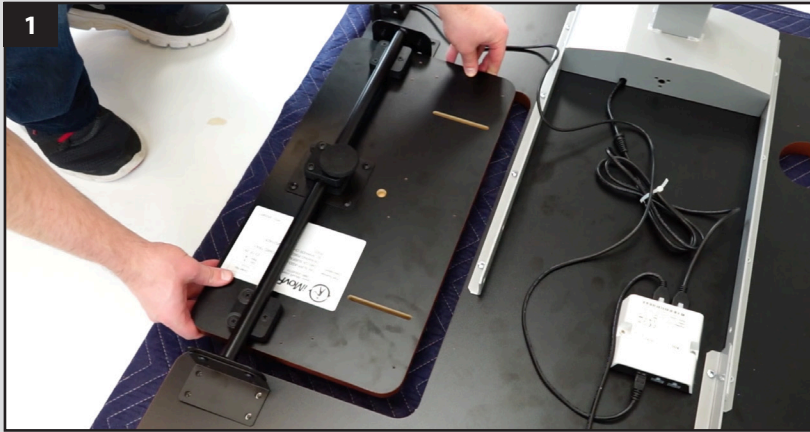

STEP 13.3

TURN DESK OVER

1. With a helper, flip your desk right side up.



STEP 13.4

ATTACH KEYBOARD FENCE

1. Tilt Keyboard Platform so you can easily access rear end of Platform.
Align 3 holes of Keyboard Fence (Part #20) with 3 holes on bottom of Platform.
2. Attach using 3 #10 5/8" Pan Head Phillips Screws (Part #18b).
Built-in cable guide should face up when Keyboard Platform is flat.

Keyboard Fence

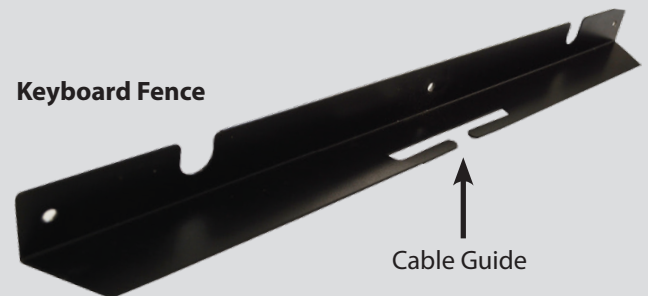

STEP 13.5

ATTACH RUBBER KEYBOARD BUMPERS

1. Fit Carriage Bolts (Part #21a) through 2 slots cut into Keyboard Platform.

Note: Carriage Bolt heads should be flush with underside of Keyboard Platform.

2. Twist Rubber Bumpers (Part #21b) over screw threads to secure in place.

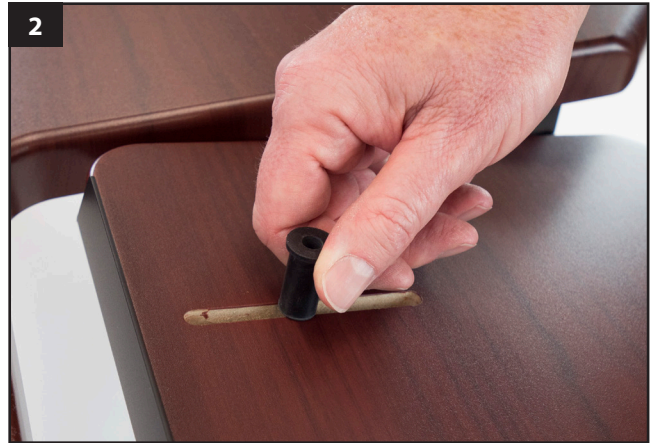

STEP 13.6

USING THE STEADYTYPE KEYBOARD PLATFORM

1. Adjust your Omega Keyboard Platform by twisting rubberized knob counterclockwise. Tilt platform for steeper or shallower angle depending on your preference. Once set to desired position, secure platform by twisting rubberized knob clockwise.

Tip: The ideal tension level blends firmness and flexibility. Tighten rubberized knob until platform tilts with two hands, but remains firm using one hand. Now there's no need to loosen knob tension each time you move between sitting and standing – a faster transition!

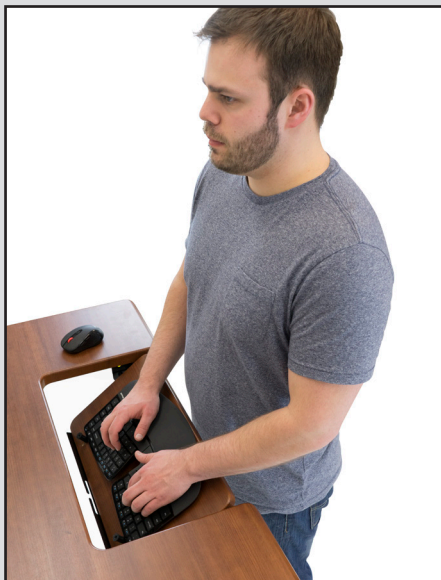

STEP 13.6 continued on next page.

USING THE STEADYTYPE KEYBOARD PLATFORM (continued)

2. Your Omega Keyboard Platform can be set to 1 of 2 height positions. By default, it arrives set to lower position. You can raise Platform higher by removing 2 hex screws from both ends of Keyboard Platform Mounting Assembly, and re-inserting screws through upper set of holes.



Tip: Upper position will allow keyboard tray to rest flush with desk surface. Users with thick keyboards may prefer lower position.

3. To make sure your keyboard fits on the Omega tray, you may need to adjust rubber bumpers forward or back depending on keyboard shape and size. Simply loosen rubber bumpers, slide them to desired location, and retighten.

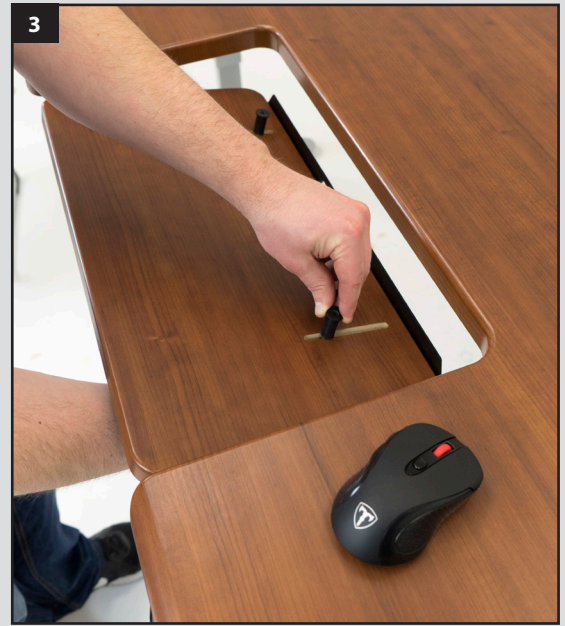

STEP 14



FINAL STEPS

1. Now, flip your desk right side up. Use a level to align properly with floor. Make any necessary adjustments by screwing/unscrewing Leveling Pads on bottom of feet.

2. Plug in Power Supply to 3-prong outlet, and use Handset to adjust desk height. You're ready to enjoy a healthier, more productive workday!



After connecting all cables and testing desk is working properly, you may want to use supplied self-adhesive cable guides to tidy up for a cleaner appearance. For more cable management gear, visit:

www.imovr.com/cable-management-video

CONTROLLER INSTRUCTIONS

INITIAL CALIBRATION

The initialization procedure must be completed before the desk can be used.



Step	Operation	Result
1	Press ▲ or ▼ to awaken controller.	Desk height displays on screen.
2	Press and hold ▲▼ simultaneously for 5+ seconds.	Small "house" icon displays on bottom left corner. Make sure to press arrows at precisely the same time. If the "house" icon doesn't appear, retry until it does.
3	Press and hold ▼ to lower desk to bottom height.	Initial Calibration Complete.

Note: Each time the desk is unplugged, you will need to re-calibrate by bringing it to its lowest position.

MOVE UP AND DOWN

Step	Operation	Result
1	Press and hold ▲.	Desk raises.
2	Release ▲.	Desk stops.
3	Press and hold ▼.	Desk lowers.
4	Release ▼.	Desk stops.

SET MEMORY POSITIONS

UPPER HEIGHT LIMIT

Step	Operation	Result
1	Press and hold ▲ or ▼ to position desk at desired height limit.	Desk raises or lowers to desired height limit.
2	Quickly press ▲▼ together 3 consecutive times.	"S" will display, flashing. Make sure to press arrows at precisely the same time. If the "S" doesn't appear, retry until it does.
3	Press ▲ once to set upper height.	"SU" will display, flashing. Upper height limit set.*

**To drive beyond memory positions, hold up or down arrow for 2+ seconds. Your memory positions will remain saved.*

SET MEMORY POSITIONS

LOWER HEIGHT LIMIT

Step	Operation	Result
1	Repeat steps 1-2 above.	"S" will display, flashing.
2	Press ▼ once to set lower height.	"SL" will display, flashing. Lower height limit set.*

**To drive beyond memory positions, hold up or down arrow for 2+ seconds. Your memory positions will remain saved.*

MOVE TO MEMORY POSITIONS

Step	Operation	Result
1	Press and hold ▲ or ▼ arrow.	Desk raises/lowers until reaching saved position.

CLEAR MEMORY POSITIONS

This procedure is the same as the Initial Calibration.

Step	Operation	Result
1	Press ▲ or ▼ to awaken controller.	Desk height displays on screen.
2	Press and hold ▲▼ simultaneously for 5+ seconds.	Small "house" icon displays in bottom left corner. Make sure to press arrows at precisely the same time. If the "house" icon doesn't appear, retry until it does.
3	Press ▼ to drive desk to lowest height.	Memory positions cleared.

CHANGE DISPLAY UNITS FROM CENTIMETERS (CM) TO INCHES (IN)

Step	Operation	Result
1	Press ▲ or ▼ to awaken controller.	Desk height displays on screen.
2	Quickly press ▲▼ together twice.	"CM" will display. Make sure to press arrows at precisely the same time. If "CM" doesn't appear, retry until it does.
3	Press ▲ once.	("") will display.
4	Press ▲▼ again.	Display set to Inches (in).

VERIFY YOUR HANDSET DISPLAYS CORRECT HEIGHT

Step	Operation	Result
1	Press ▼ to drive desk to lowest height.	Desk rests at lowest position.
2	Measure distance from floor to table top surface.	Proceed if variance exists between your measurement and display height.
3	Press ▲▼ together once.	"Un" displays on screen.
4	Press ▲ once.	"CAL" displays on screen.
5	Press ▲▼ together once.	Height displayed, flashing.
6	Press ▲ or ▼ until display shows correct height.	Correct height displayed.
7	Press ▲▼ together once.	"CAL" displays on screen.
8	Press ▼ twice.	Handset calibrated to correct height. Saved.



TROUBLESHOOTING

Symptom	Handling
After connecting the power, the desk does not raise.	Re-calibrate the desk. See instructions for "Initial Calibration".
	Check if the connections are correct.
	Please contact your supplier.
The legs rise slowly.	Check to see if legs are perpendicular (at 90 degrees) to the desk-top and the floor. If the legs are splayed inward or outward, the motor will not operate at an optimum level.
	Check that the weight load on the table is not excessive.
	Confirm the line voltage is 110v.
One leg moves while the other does not.	Check the drive cable connection.
	Check to see if legs are perpendicular (at 90 degrees) to the desk-top and the floor. If the legs are splayed inward or outward, the motor will not operate at an optimum level.
	Please contact your supplier.
Table slides down on its own.	Check that the weight load on the table is not excessive.
	Please contact your supplier.

FINAL TOUCHES

ADD A MONITOR ARM

For the best standing desk ergonomics, you'll want to add a monitor arm to your workstation. Monitor arms keep your screen(s) at an ergonomic location (height, depth, and angle), which means less neck and eye strain and more comfort during your standing desk experience. iMovR offers several varieties, including those designed for heavy monitors and dual monitors. Add one to your desk system -- you'll keep your eyes on the prize, ergonomically speaking.

Visit: www.iMovR.com/accessories/monitor-arms.html

FIND A STANDING MAT

No standing desk system is complete without an anti-fatigue standing mat! If you want to boost your standing endurance, try one of our EcoLast Standing Mats. Made from 100% polyurethane material, our mats are durable, environmentally friendly, and come with an incredible lifetime warranty. A variety of sizes and colors are available to fit your workstation needs.

Visit: www.iMovR.com/standing-mats.html

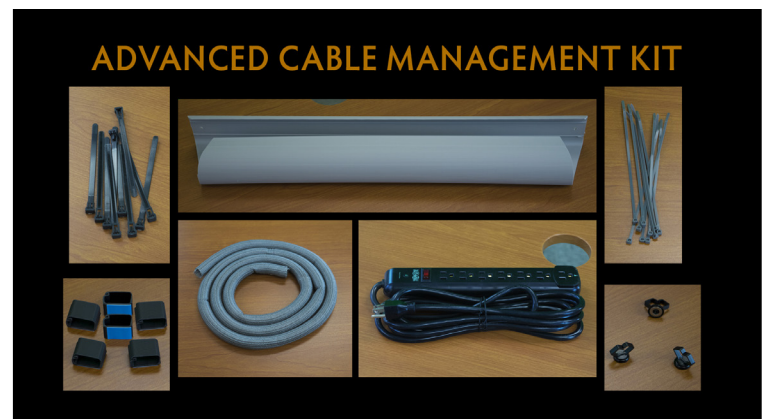

MANAGE YOUR CORDS

Invest in a cable management kit! It's the smart way to tidy up all your loose or draped cables. We offer a basic kit for minimalist workstations, and an advanced kit for those with a few more cords to corral.

Find both at: www.iMovR.com/cable-management-video

MAINTENANCE AND GOOD-SENSE TIPS

RE-TIGHTEN

After first week of use it's a good idea to check and re-tighten any screws / bolts.

CLEANING THE BASE

Clean the base frame by wiping it down with a microfiber cloth moistened with a standard household cleaning solution. Never use solvents or abrasive or corrosive compounds on the frame. The base should be cleaned at regular intervals to remove dust and dirt. Inspect for mechanical damage; worn or broken parts should be replaced.

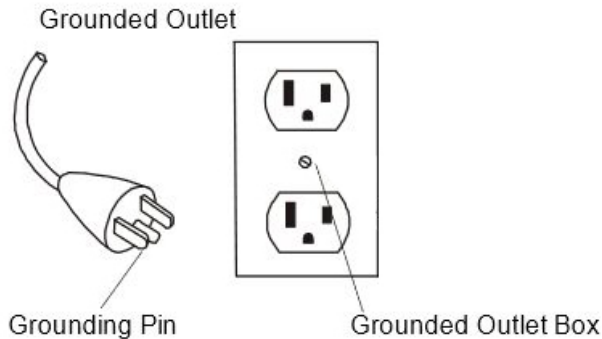

WARNING: Always plug this desk into a grounded, 3-prong outlet. Use the power cord provided with the product.

CLEANING THE DESKTOP

All desktops are manufactured with a "3D lamination" process that results in an extremely durable surface, similar to what's often used in hospital environments. As such, it can stand up to most cleaning solutions without risk of discoloration or degradation. Anti-bacterial solutions may be used. Always test new cleaning solutions on a less-seen surface before first using on the entire desktop.

EXTENDED NON-USE

Unplug the power cord if you do not intend to use the desk for a long period of time.



WARNING: The components used are quite heavy and care should be exercised when lifting and moving the base and desk both during assembly and during use.

SPECIFICATIONS

CASCADE/ENERGIZE™ BASE

Lift Capacity: 220 lbs.
Height Adjustment Range: 22.5" to 48"
*Range figures are based on the frame only.
For true height range figures, add your desk top thickness.*
Width Adjustment Range: 48" to 72"
Noise Level: 55 dB
Travel Speed: 1.3" per second
Controller: Digital – Programmable with 2 saved positions
Feet: 23 5/8" long
Anti-Collision: Yes
Power Consumption: .1W standby
Manufacturing Origin: Europe (GSA compliant)
Warranty: 10 years on all parts
THIS WARRANTY APPLIES ONLY IN THE U.S. AND CANADA. WARRANTIES OUTSIDE OF THE UNITED STATES MAY VARY. PLEASE CONTACT YOUR LOCAL DEALER FOR DETAILS.

CASCADE/ENERGIZE™ TABLETOP

Lamination type: Omnova Surf(x) ultra durable
Tabletop thickness: 3/4" or 1 1/8"
Available sizes: 24" or 30" depth; 47", 53", 59", 65", 71" length
Recessed Nuts : Yes – on 1 1/8" tabletops
Grommets: Dual 60mm (2.35") fully laminated grommet holes
Manufacturing Origin: Michigan, USA
Warranty: 5 years on the tabletop
THIS WARRANTY APPLIES ONLY IN THE U.S. AND CANADA. WARRANTIES OUTSIDE OF THE UNITED STATES MAY VARY. PLEASE CONTACT YOUR LOCAL DEALER FOR DETAILS.

WARRANTY

The iMovR Cascade/Energize warranty coverage includes 10 years on all the component parts and 5 years on the tabletop.

THIS WARRANTY only covers defects as specified herein and does not include defects or damages attributable to improper installation, misuse or normal surface weathering, or defects or damages caused by accidents or fire or other casualty or Acts of God, or any other causes, or occurrences beyond the manufacturer's control. The exclusive remedial action provided for the customer hereunder shall be repair, restoration or replacement of the components as are found to be defective.

TABLE TOP: The replacement of new materials for those as may result in a color variance in comparison to the originally installed laminates due to slight color or texture changes by laminate manufacturers and is not indicative of a defect. IMovR reserves the right to substitute such laminates as are then being manufactured and is only obligated to match color and quality with such products as its manufacturing at the time of replacement.

ELECTRIC BASE FRAME: New base frames may have paint defects or scratches on components that are hidden beneath the surface of the desk, which are normal. Painted components that are normally visible to sitting or standing users after installation of the table top, that arrive in damaged condition, will be replaced under this warranty if iMovR is notified before the component is installed.

THIS WARRANTY is limited to repair, restoration and/or replacement by iMovR of any defective unit provided the manufacturer: (a) receives a written, faxed or e-mailed notice of claim under this warranty, including sufficiently high resolution photographs that clearly show the nature of the damage, and (b) within 30 days after notice of claim, is in receipt of the defective unit at its place of business, unless this requirement is waived by iMovR. The manufacturer will arrange for retrieval of the defective product via its carrier-of-choice. In some cases the manufacturer may elect not to retrieve the defective component, and may opt to send a replacement product based only on photographic evidence of warranted defects. If upon receipt and inspection of the returned component it is determined that the damage was not due to a manufacturing flaw but rather one of the exempted reasons stated above, the costs of shipping the units to and from the manufacturer, plus the cost of the replacement component, shall be charged back to the customer.

LIMITATION OF LIABILITY: IT IS UNDERSTOOD AND AGREED THAT MANUFACTURER'S LIABILITY, WHETHER IN CONTRACT, IN TORT UNDER ANY WARRANTY, IN NEGLIGENCE OR OTHERWISE, SHALL NOT EXCEED THE RETURN OF THE AMOUNT OF PURCHASE PRICE FOR THE DEFECTIVE ITEM PAID BY PURCHASER AND UNDER NO CIRCUMSTANCES SHALL SELLER BE LIABLE FOR SPECIAL, INDIRECT OR CONSEQUENTIAL DAMAGES. NO ACTION, REGARDLESS OF FORM, ARISING OUT OF THE TRANSACTIONS UNDER THIS AGREEMENT MAY BE BROUGHT BY THE PURCHASER MORE THAN ONE YEAR AFTER THE CAUSE OF THE ACTION HAS ACCRUED.

SOME STATES DO NOT ALLOW LIMITATIONS ON HOW LONG AN IMPLIED WARRANTY LASTS, AND SOME STATES DO NOT ALLOW THE EXCLUSION OR LIMITATION OF INCIDENTAL OR CONSEQUENTIAL DAMAGES, SO THE ABOVE LIMITATIONS OR EXCLUSIONS HEREIN MAY NOT APPLY TO YOU. THIS WARRANTY GIVES YOU SPECIFIC LEGAL RIGHTS, AND YOU MAY ALSO HAVE OTHER RIGHTS, WHICH VARY, FROM STATE TO STATE. THIS WARRANTY APPLIES ONLY IN THE U.S. AND CANADA. WARRANTIES OUTSIDE OF THE UNITED STATES MAY VARY. PLEASE CONTACT YOUR LOCAL DEALER FOR DETAILS.

TO OBTAIN warranty repair please contact the iMovR Customer Care Department with the contact information provided below.

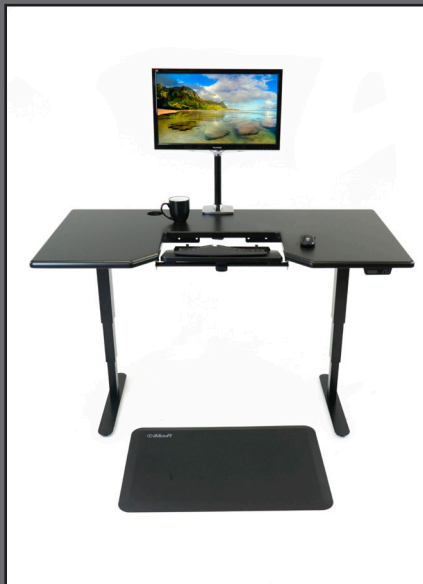

IMovR Contact Information:

Phone: (888) 208-6770 or (425) 999-3550

Fax: (425) 999-3550

E-mail: customer care@iMovR.com

Live Chat: www.iMovR.com