

A

Shelf Bracket
111604-124

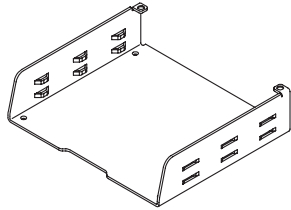

D

Shelf
111629-124

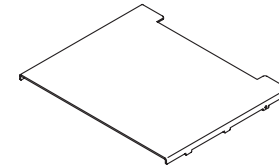

B

Enclosure
111603-124

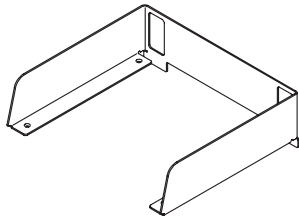

E

Cover
111605-248

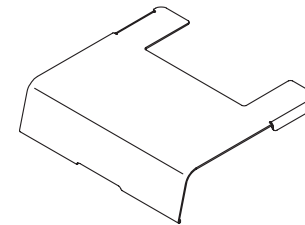

C

#6 x 3/4" FHPhS
711880

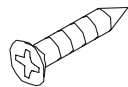

1

Place the platform base on the work surface. Align the platform tabs at the back of the work surface as shown.

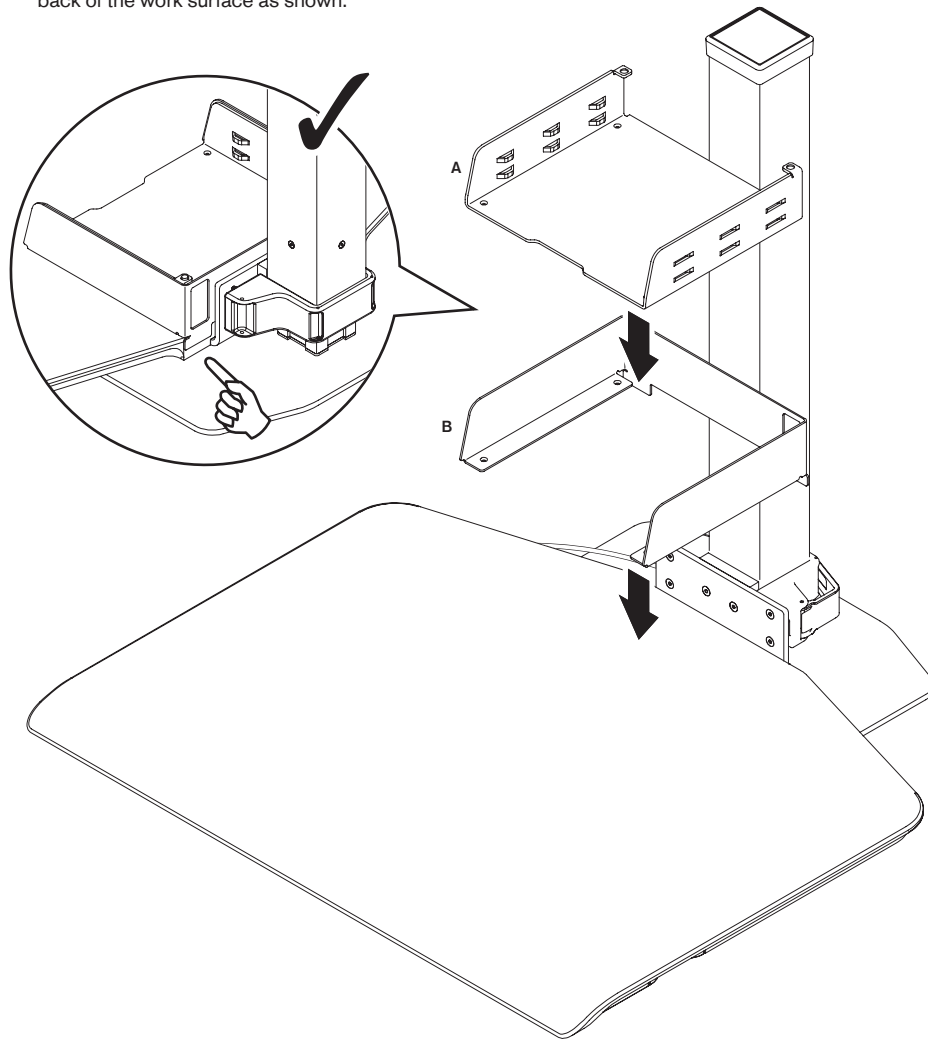

2

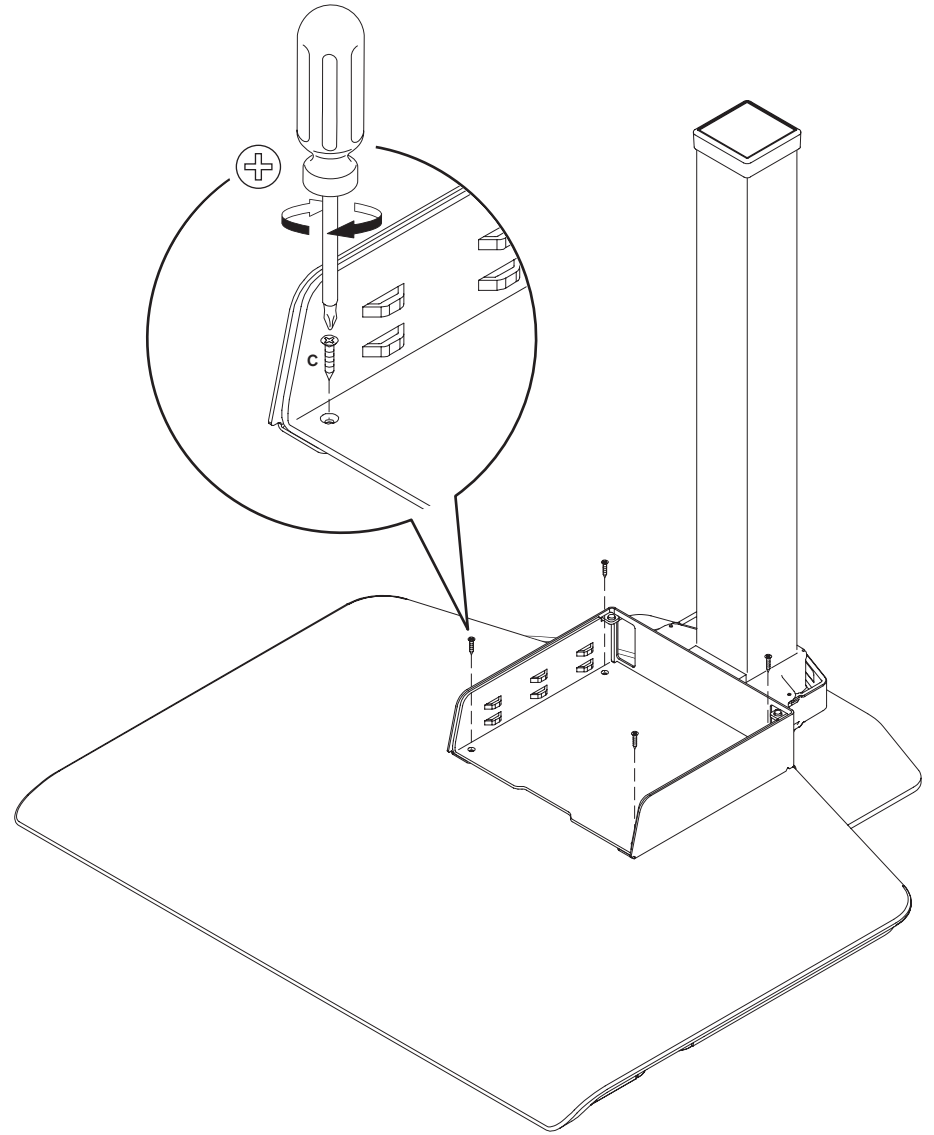

3

Choose from **three height settings** for your iMac.

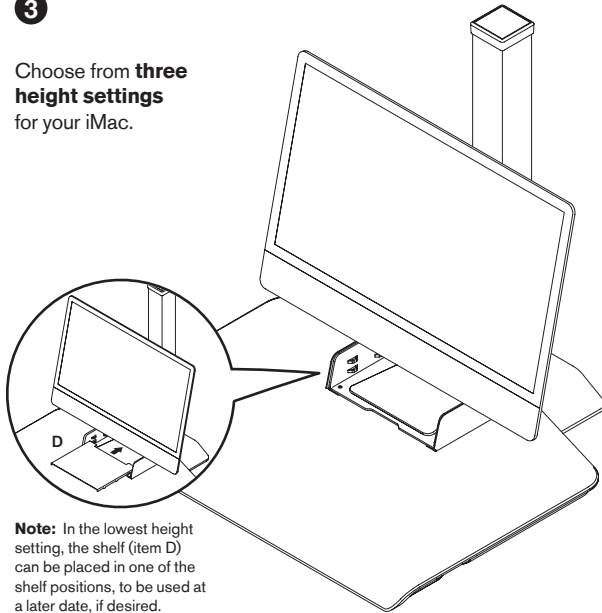

Note: In the lowest height setting, the shelf (item D) can be placed in one of the shelf positions, to be used at a later date, if desired.

OR

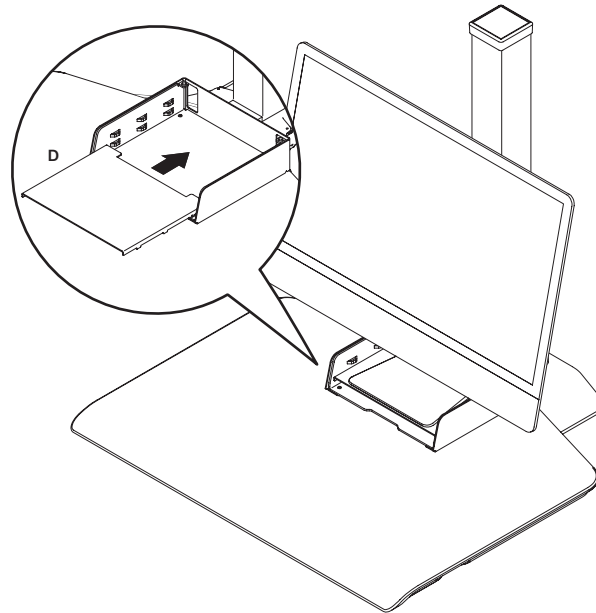

OR

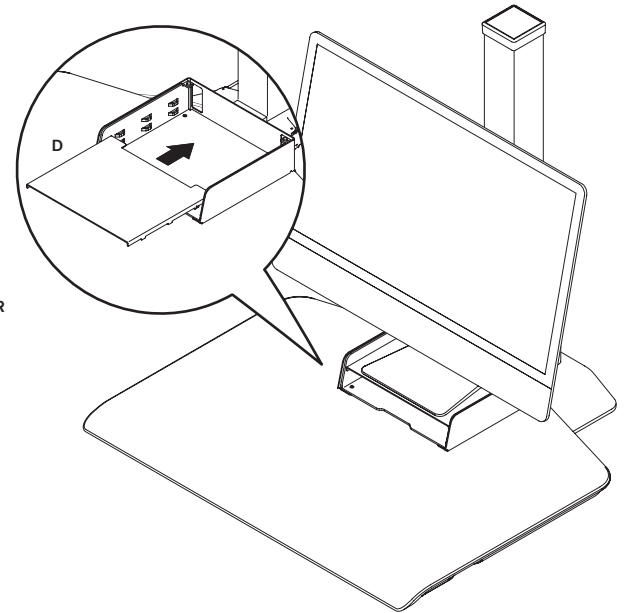

4

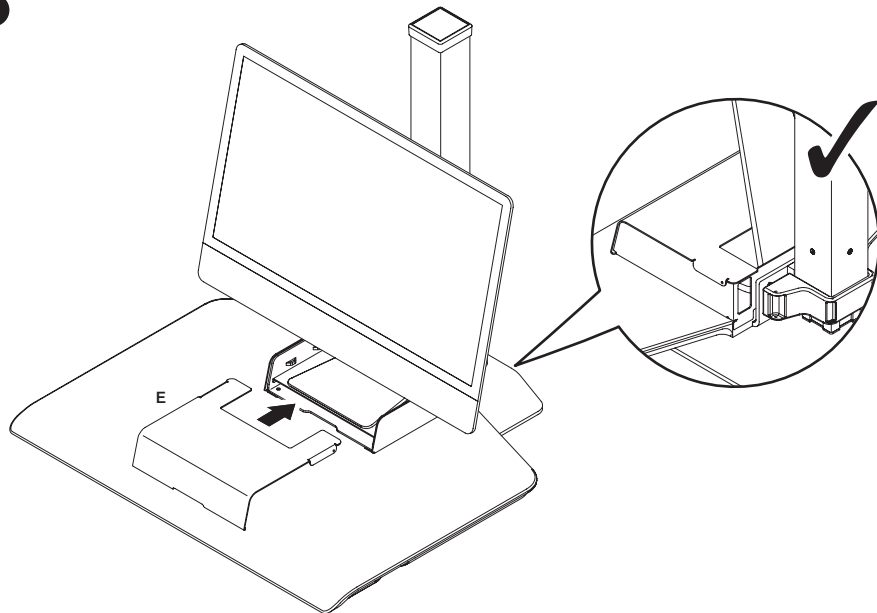

i

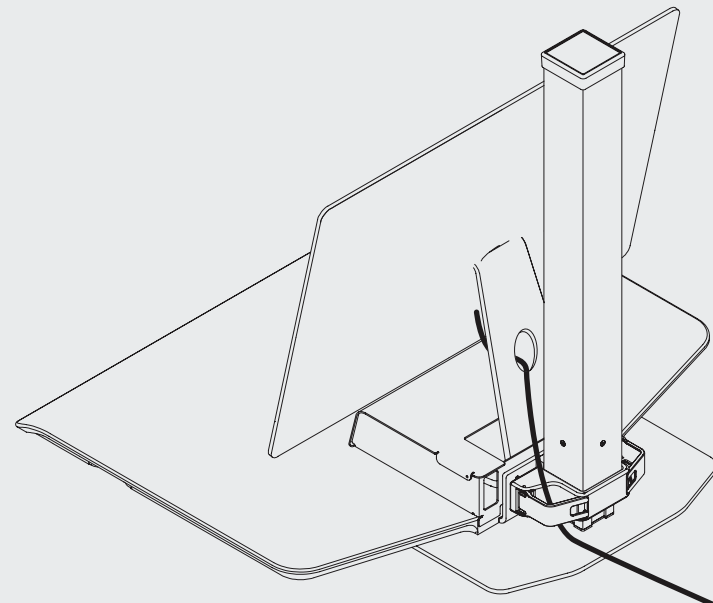

STEP 1 | COLUMN..... Page 3

STEP 2 | MOUNT..... Page 4

STEP 3 | WORK SURFACE..... Page 5

STEP 4 | BEAM..... Page 6

STEP 5 | MONITOR TILTER..... Page 7

STEP 6 | MONITOR CUPS..... Page 8

STEP 7 | CABLE MANAGEMENT..... Page 9

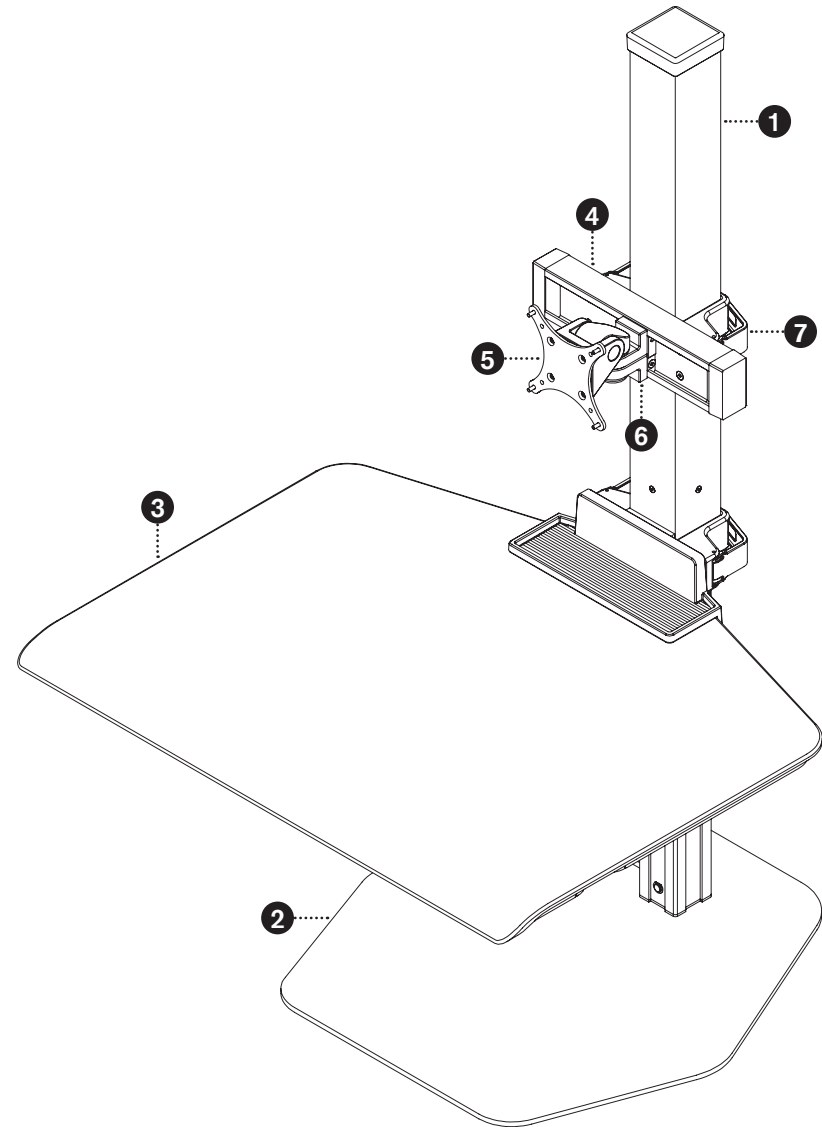











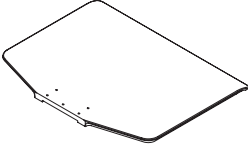



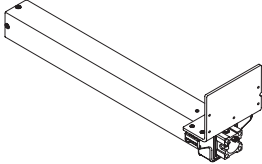
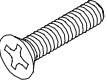
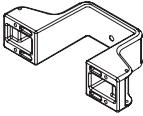

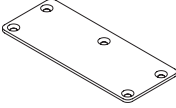
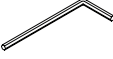

NOTE: Depending on your Winston Workstation® configuration, you may not receive all the parts shown within this instruction booklet.

Installation may require two people.

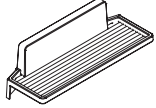
Depending on your Winston Workstation® configuration, **you may not receive all parts** shown below.

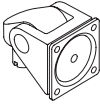
WNST-APL-1 & WNST-APL-2

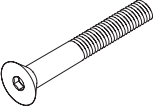
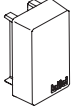
Winston Workstation® for Apple iMac | Parts List

<p>A</p> <p>Work Surface 111435</p> 	<p>F</p> <p>3/8-16 x 1" FHSCS 701124</p> 	<p>K</p> <p>Center Beam (10" or 30") 111098-10 or 111098-30</p> 	<p>P</p> <p>Column Cap 111275-708</p> 	<p>U</p> <p>Monitor Cup 411351</p> 
<p>B</p> <p>Column 411470</p> 	<p>G</p> <p>Screws 713273</p> 	<p>L</p> <p>Column Clamp 111040</p> 	<p>Q</p> <p>10-32 x 3/8" PhPHS 702281</p> 	<p>V</p> <p>Dog Washer 111230-603</p> 
<p>C</p> <p>Felt Pad 111464</p> 	<p>H</p> <p>Top Plate 111736</p> 	<p>M</p> <p>1/8" Allen Wrench 701312</p> 	<p>R</p> <p>75/100 mm VESA Adapter 105587</p> 	<p>W</p> <p>10-32 x 1/2" FHSCS 711240</p> 
<p>D</p> <p>Freestanding Base 111248</p> 	<p>I</p> <p>Utility Tray 113025</p> 	<p>N</p> <p>7/32" Allen Wrench 701127</p> 	<p>S</p> <p>Standard Monitor Tilter 405397</p> 	<p>X</p> <p>Column Cable Clip 111203-708</p> 
<p>E</p> <p>Cable Retainer 111735</p> 	<p>J</p> <p>FHSCS 10-32 x 1-1/2" 711101</p> 	<p>O</p> <p>End Cap 111159-708</p> 	<p>T</p> <p>M4 x 12mm PhPHS 702096</p> 	

STEP 1

COLUMN

IMPORTANT: Do not pull excessively on cable – doing so may result in accidental actuation of column.

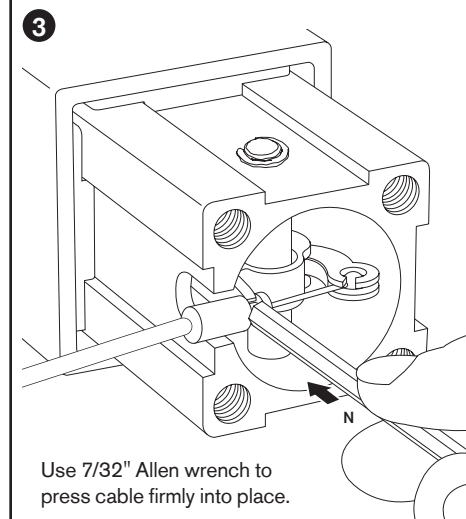
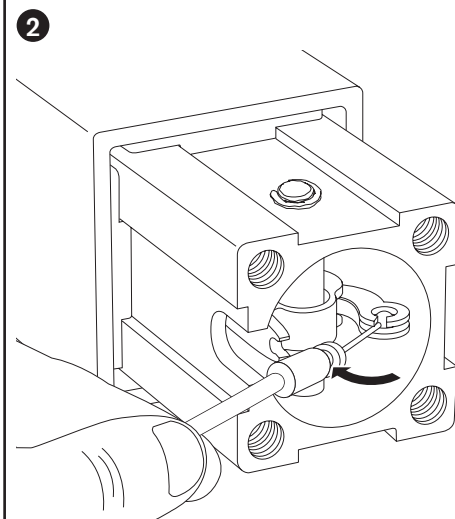
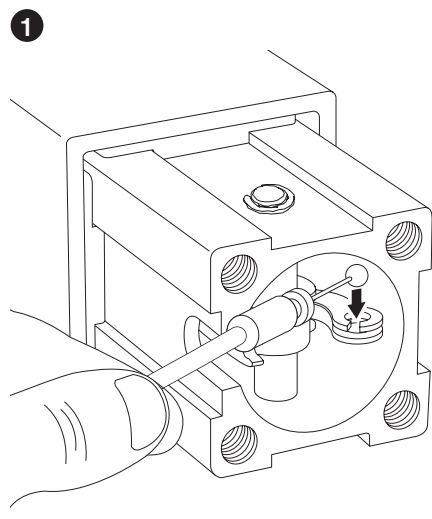
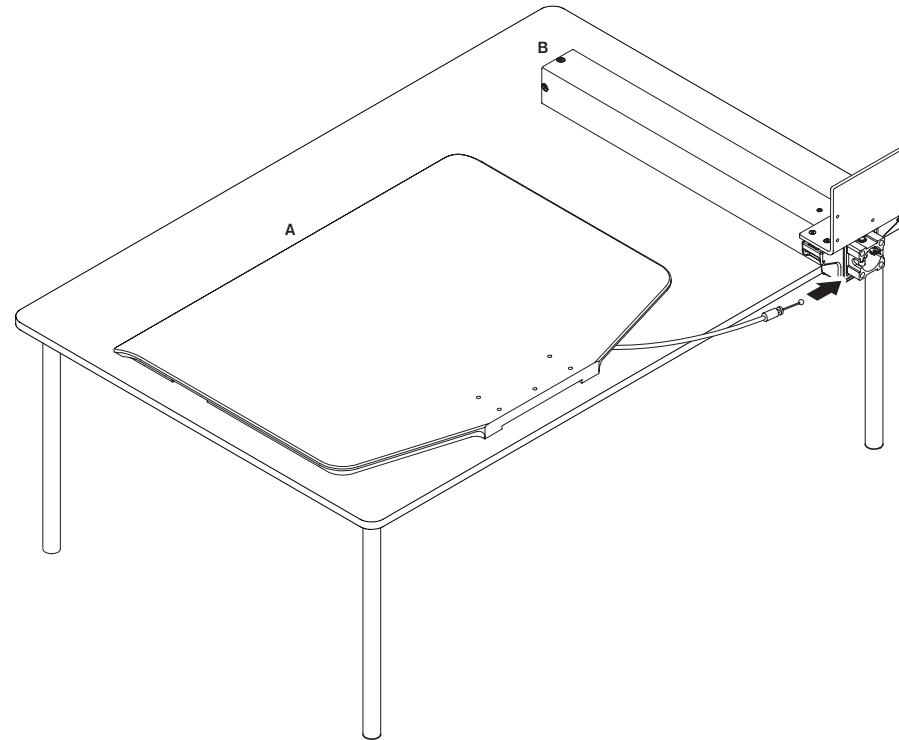

Use 7/32" Allen wrench to press cable firmly into place.

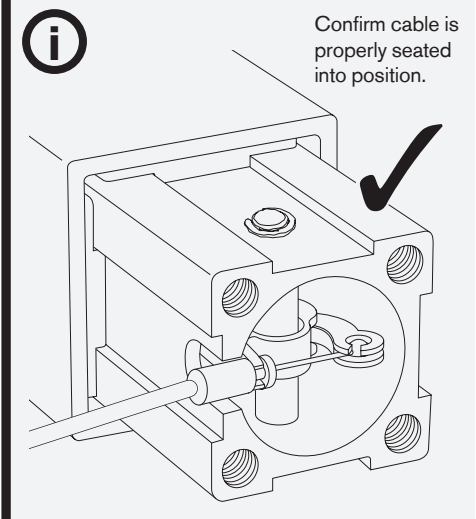

Confirm cable is properly seated into position.

STEP 2

MOUNT

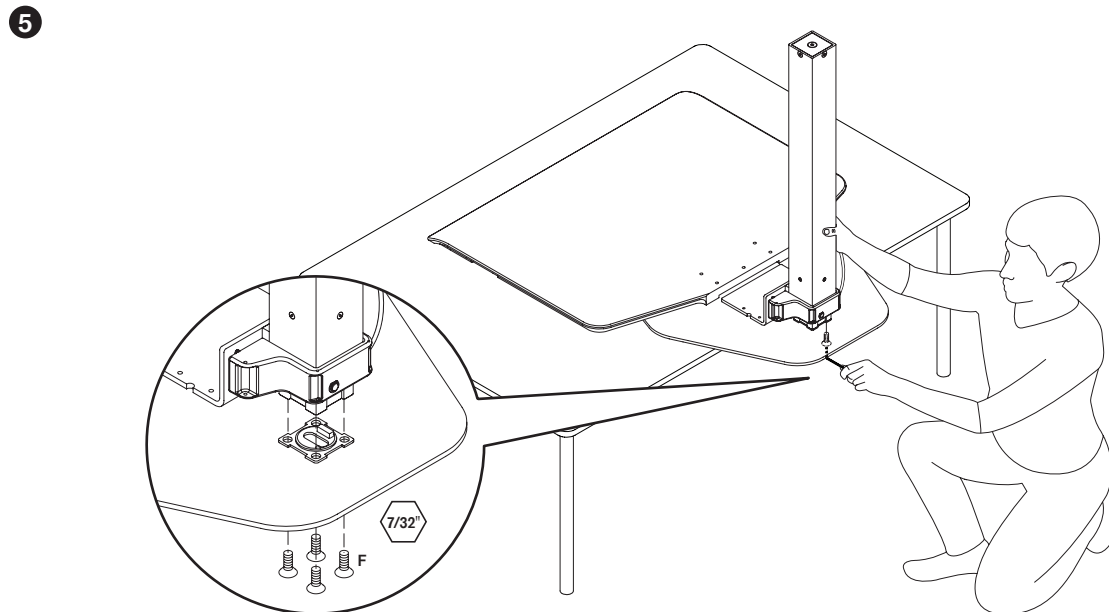
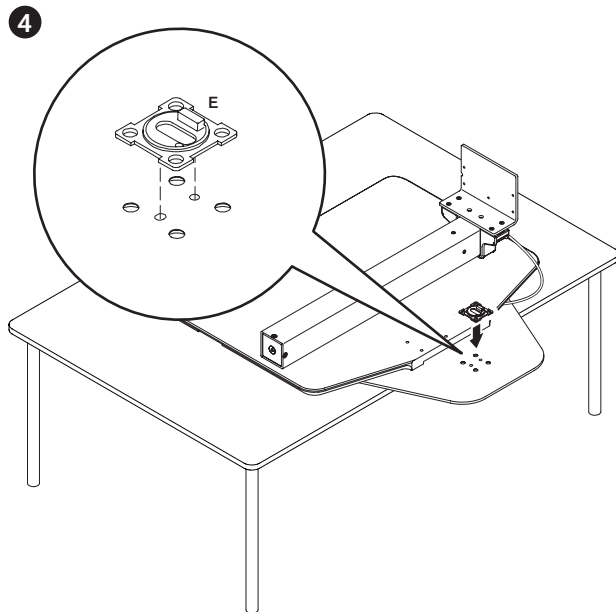
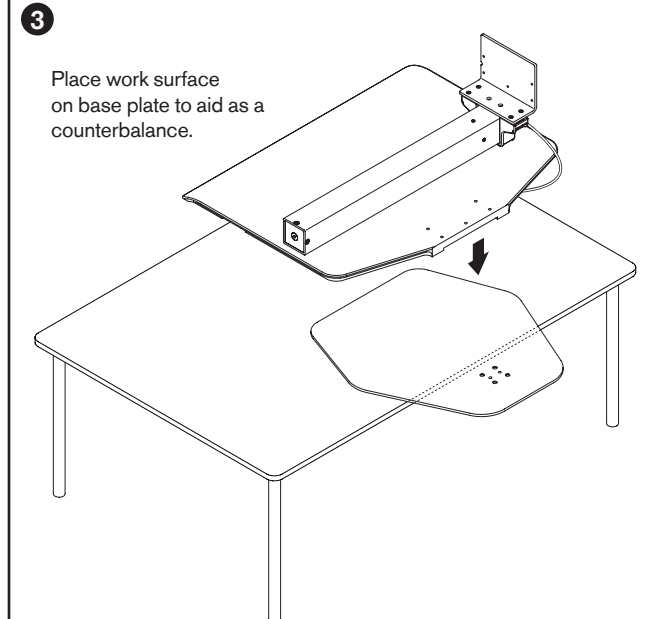
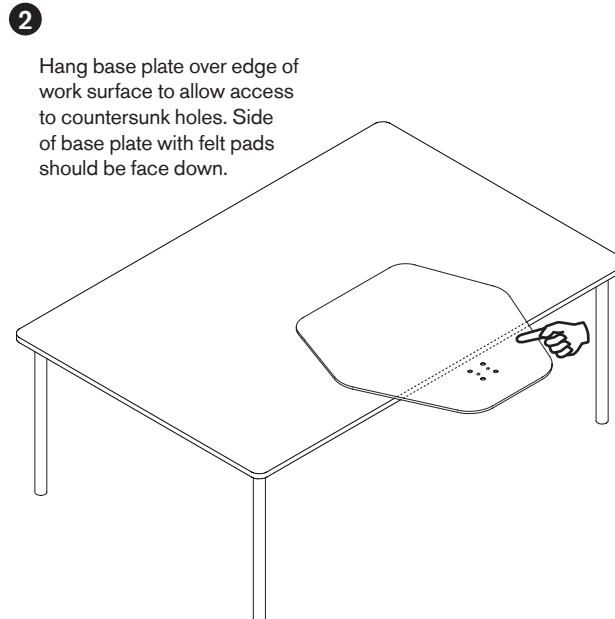
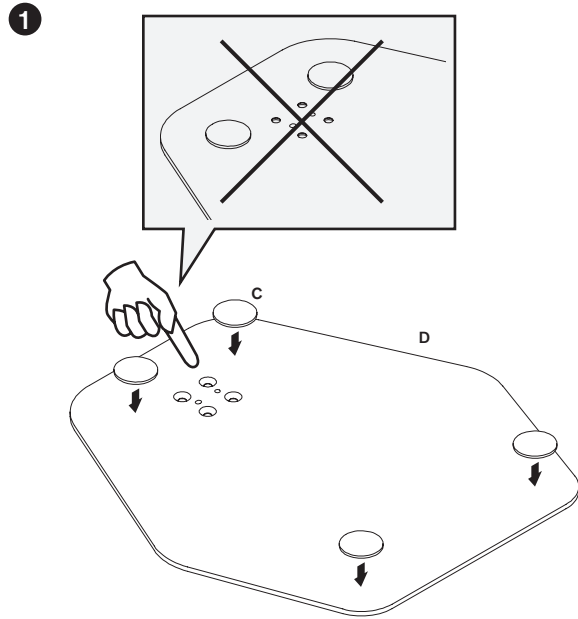

STEP 3

WORK SURFACE

1

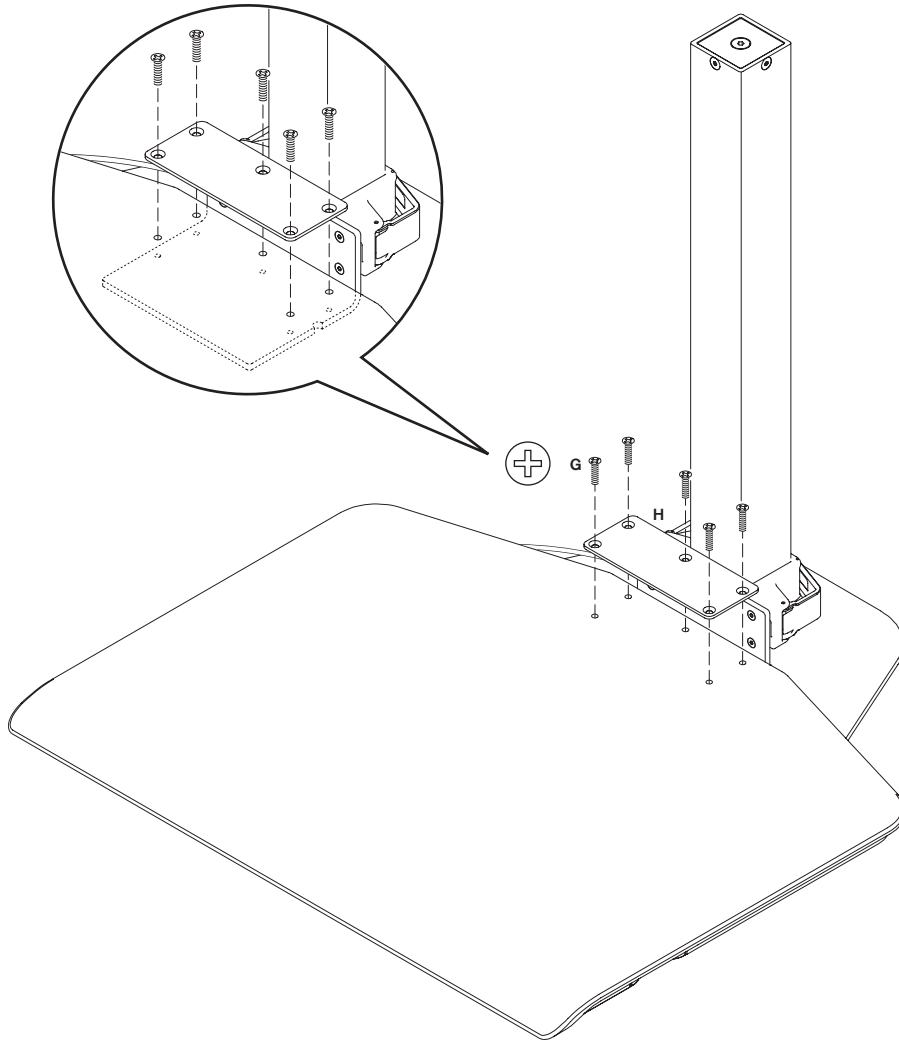

2

Slide utility tray onto work surface.
Utility tray simply rests on top of
work surface.

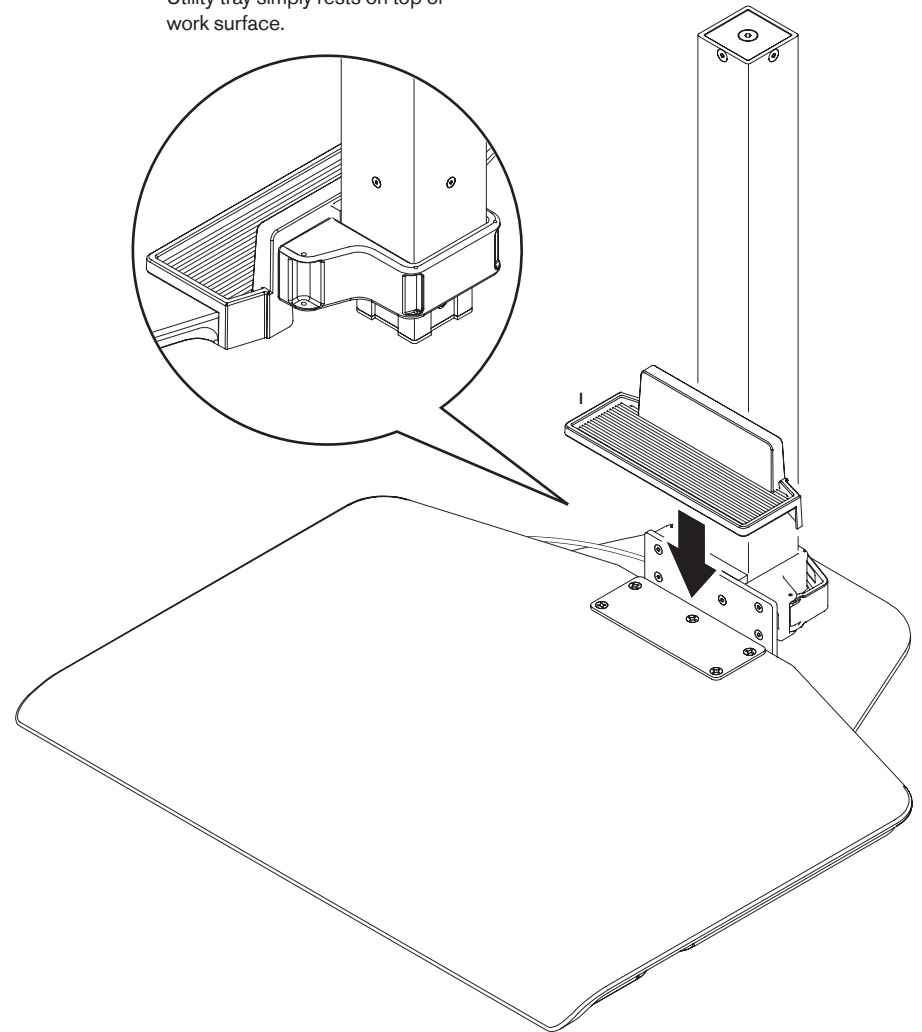

STEP 4

BEAM

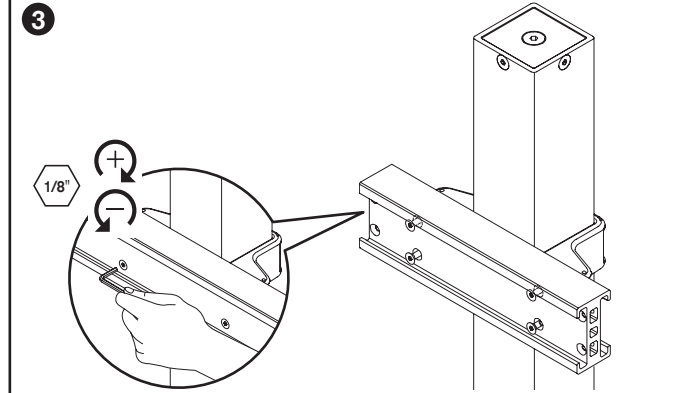
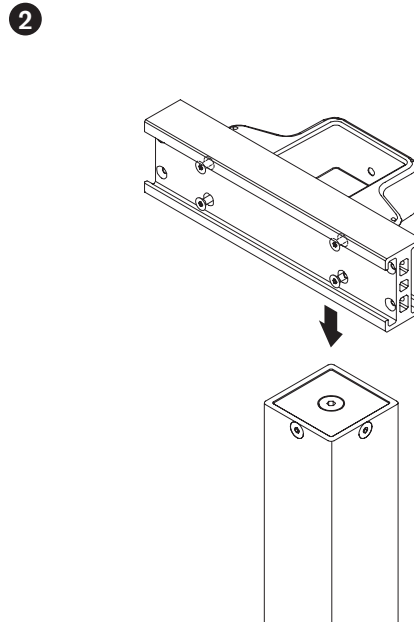
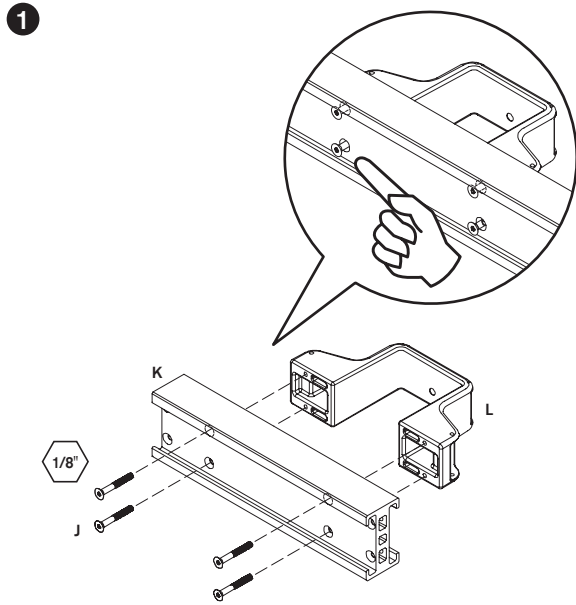

IMPORTANT: Tighten bolts evenly. The beam should sit flush against the column, ensure there are no gaps. Also, it is important the work surface clamp is level.

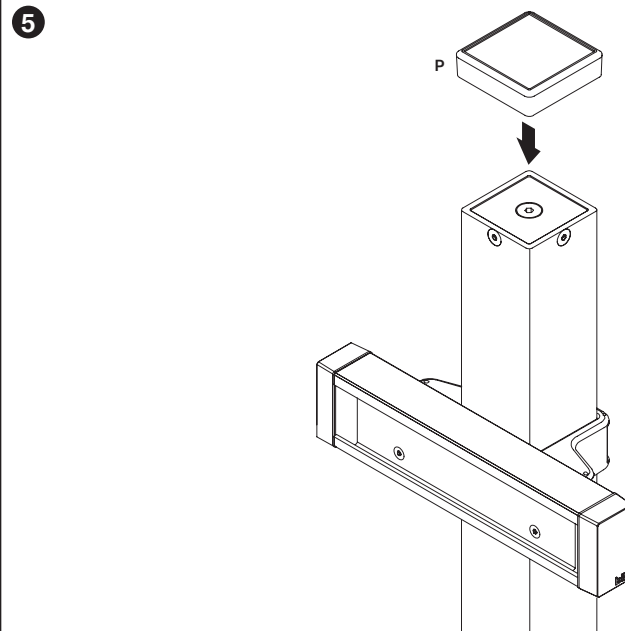
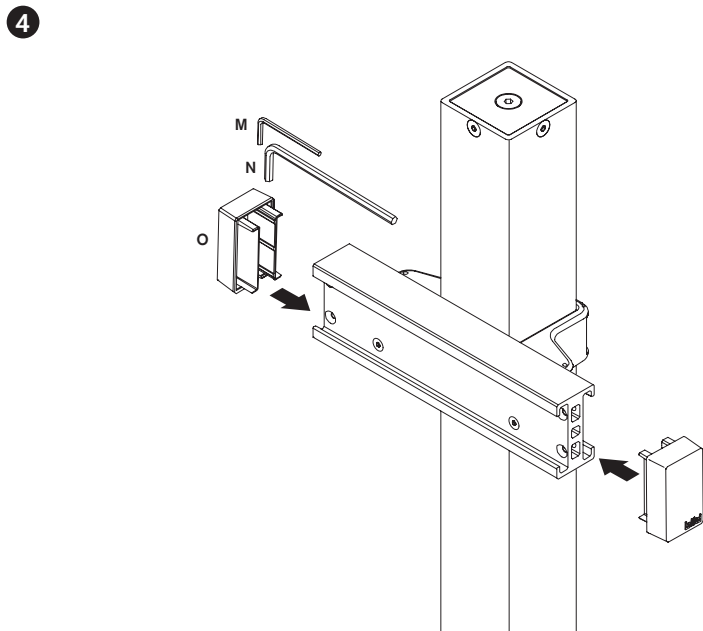
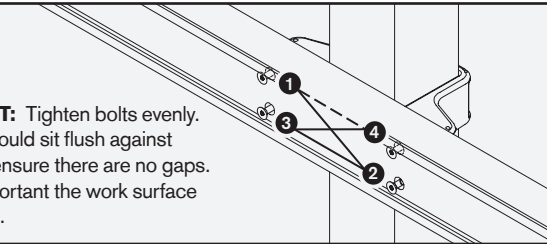

STEP 5

MONITOR TILTER

1

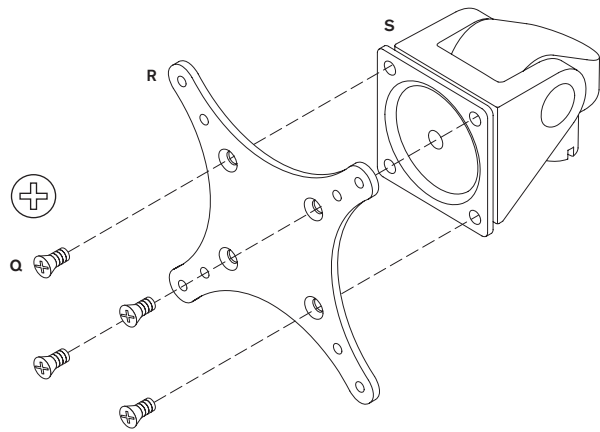

2

NOTE:
Requires VESA compatible iMac
or Apple VESA adapter
(not included).

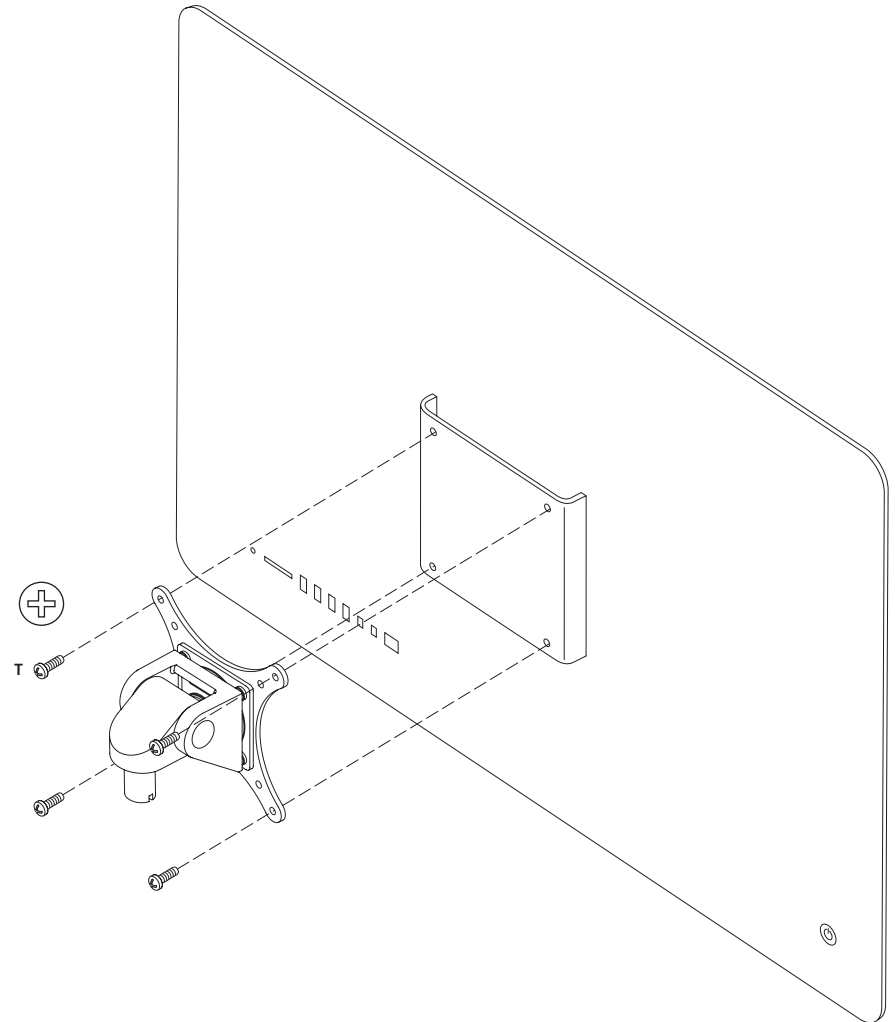

STEP 6

MONITOR CUPS

1

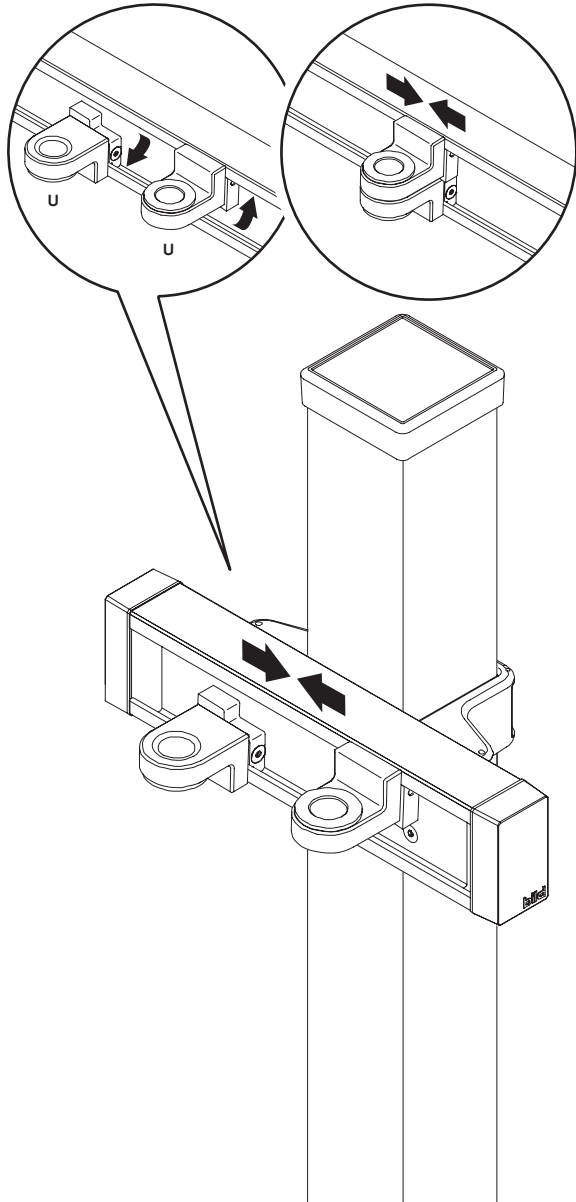

2

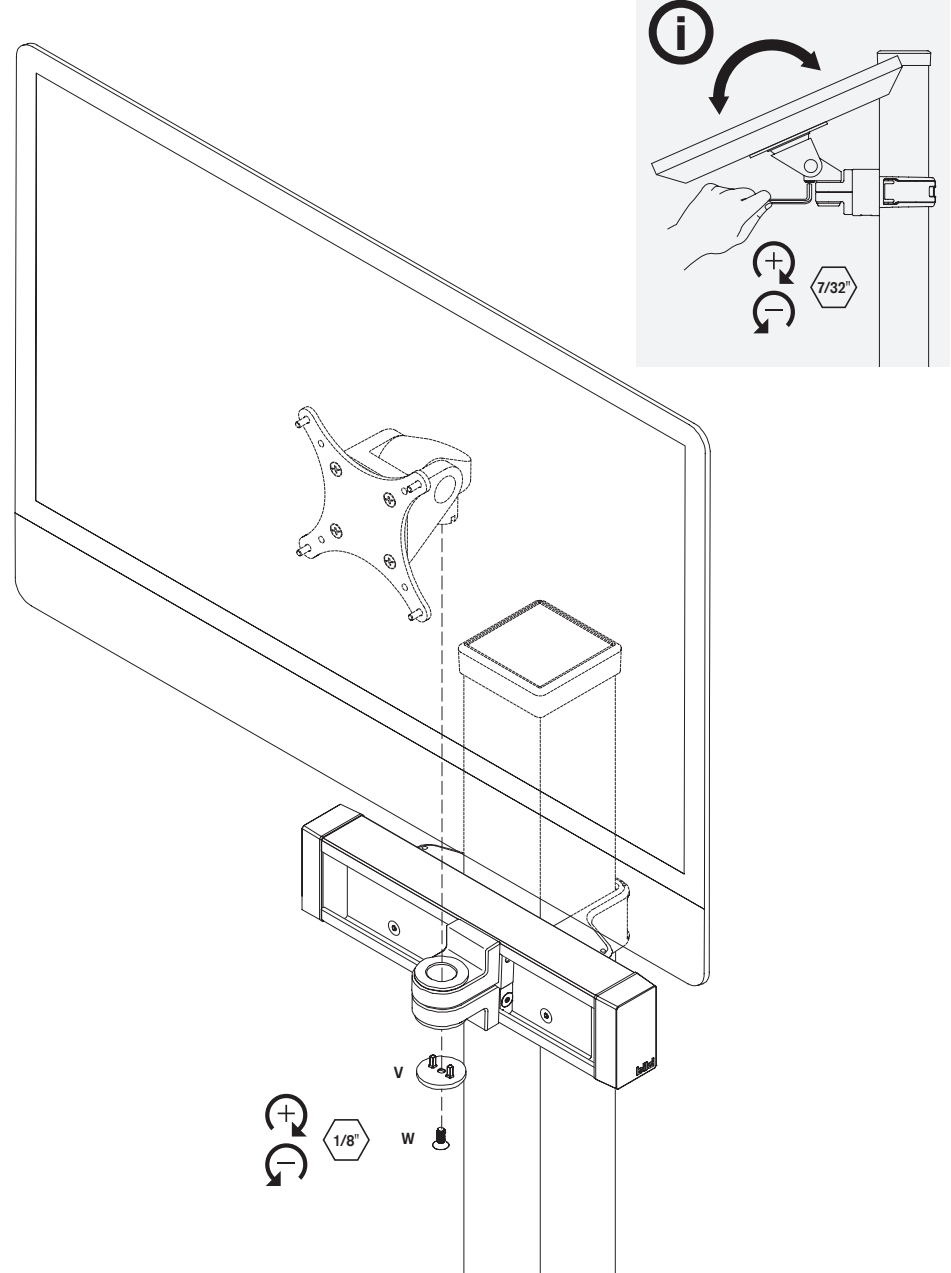

STEP 7

CABLE MANAGEMENT

1

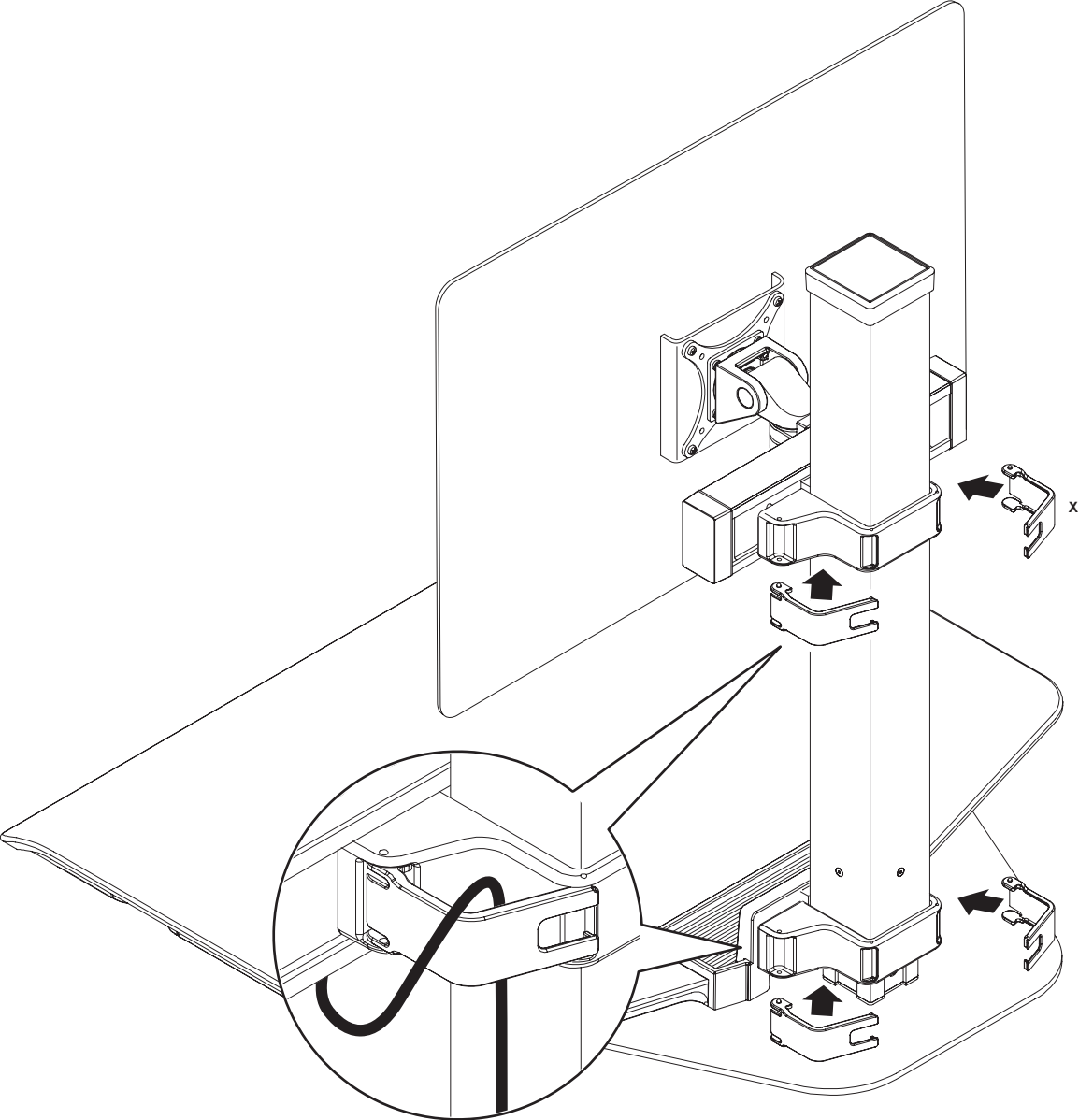

HEIGHT ADJUSTMENT

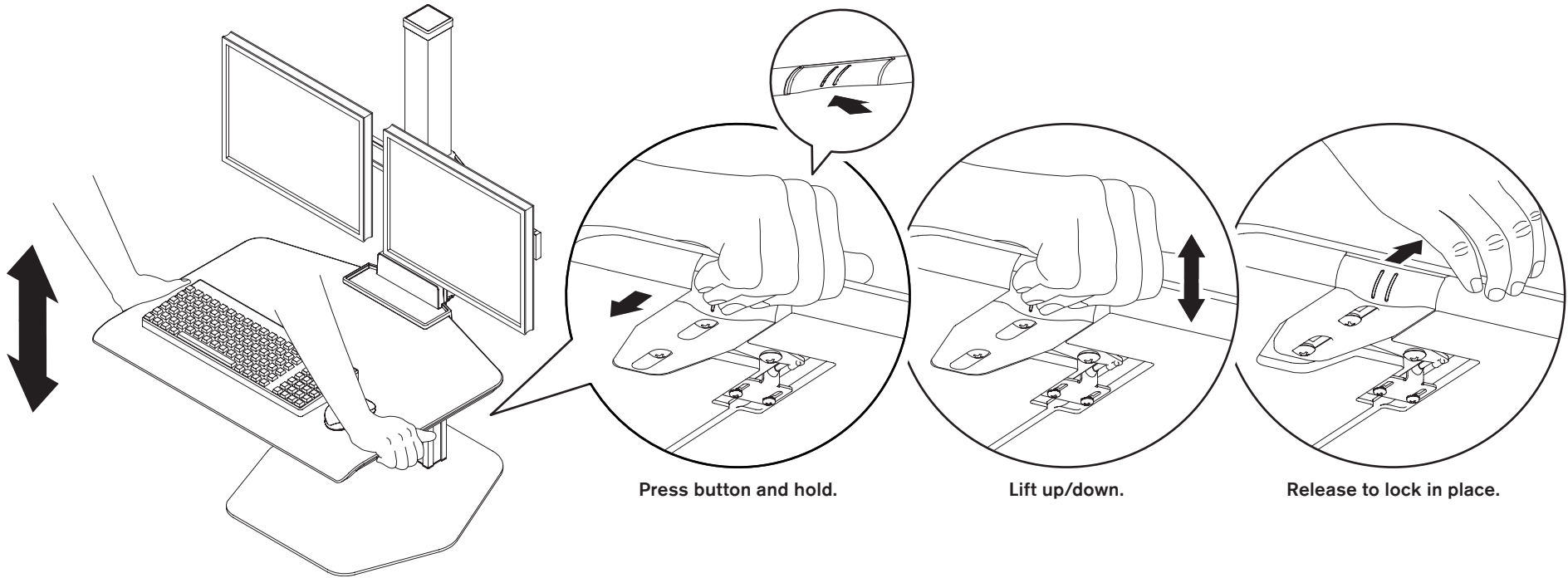

i Is your height adjust button not working? If so, make the adjustments below.

- 1 Slide workstation so that the work surface hangs over desk edge to allow access to underneath the work surface.
- 2 Loosen the two screws as shown.
- 3 Slide bracket in the direction shown and tighten screws.
- 4 Test height adjust button – readjust by repeating the steps above as necessary.

