

	A	B	C	D	E
1	1x	1x	1x	4x M4 x 7mm	1x M3 x 6mm
2		2x	6x	4x M4 x 10mm	1x M5 x 8mm
3			4x	4x M6 x 7mm	2x M6 x 30mm
4		4x	4x M6 x 25mm	1x 4mm	2x M6 x 35mm

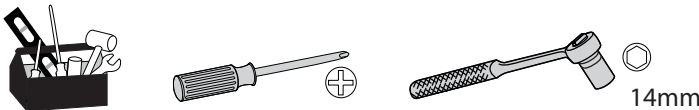

For the latest User Installation Guide please visit: www.ergotron.com



User's Guide - English
 Guía del usuario - Español
 Manuel de l'utilisateur - Français
 Gebrauchsanweisung - Deutsch
 Benutzerhandbuch - Nederlands
 Guida per l'utente - Italiano
 Användarhandbok - svenska
 ユーザーガイド : 日本語
 用户指南 : 汉语



Includes
 Constant Force™
 Technology



www.ergotron.com







USA: 1-800-888-8458
 Europe: +31 (0)33-45 45 600
 China: 400-120-3051

Japan: japansupport@ergotron.com

Hazard Symbols Review

These symbols alert users of a safety condition that demands attention. All users should be able to recognize and understand the significance of the following Safety Hazards if encountered on the product or within the documentation. Children who are not able to recognize and respond appropriately to Safety Alerts should not use this product without adult supervision!

Symbol	Signal Word	Level of Hazard
	NOTE	A NOTE indicates important information that helps you make better use of this product.
	CAUTION	A CAUTION indicates either potential damage to hardware or loss of data and tells you how to avoid the problem.
	WARNING	A WARNING indicates either potential for property damage, personal injury, or death.
	ELECTRICAL	An Electrical indicates an impending electrical hazard which, if not avoided, may result in personal injury, fire and/or death.

Safety



Important! You will need to adjust this product after installation is complete. Make sure all your equipment is properly installed on the product before attempting adjustments. This product should move smoothly and easily through the full range of motion and stay where you set it. If movements are too easy or difficult or if product does not stay in desired positions, follow the adjustment instructions to create smooth and easy movements. Depending on your product and the adjustment, it may take many turns to notice a difference. Any time equipment is added or removed from this product, resulting in a change in the weight of the mounted load, you should repeat these adjustment steps to ensure safe and optimum operation.

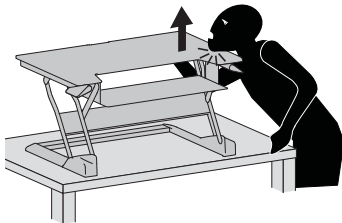

Warning: Impact Hazard! Moving Parts can Crush and Cut.
 Raise worksurface to top of vertical adjustment **BEFORE** removing equipment.
 Failure to heed this warning may result in serious personal injury and or property damage!

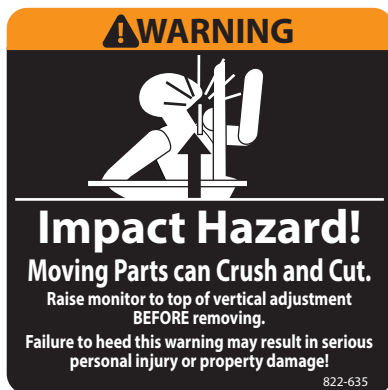

Warning: Impact Hazard! Moving Parts can Crush and Cut.
 Raise monitor to top of vertical adjustment before removing.

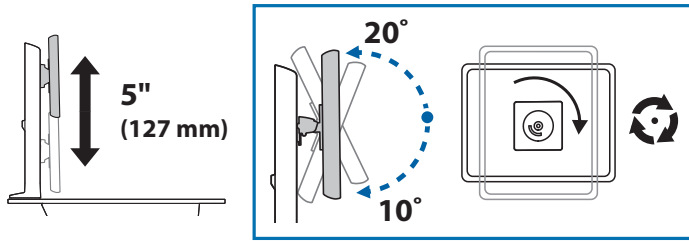

WorkFit-T

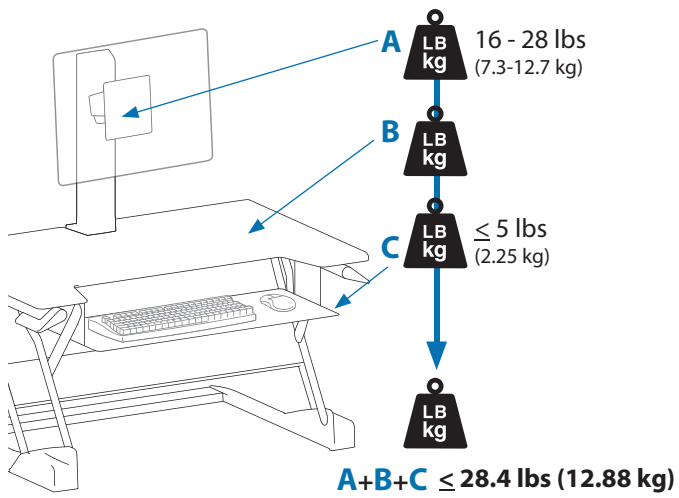

WorkFit-PD

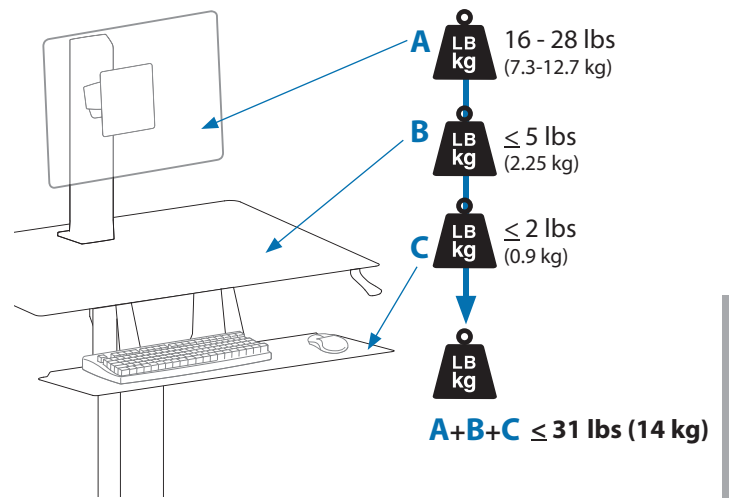

WorkFit-T

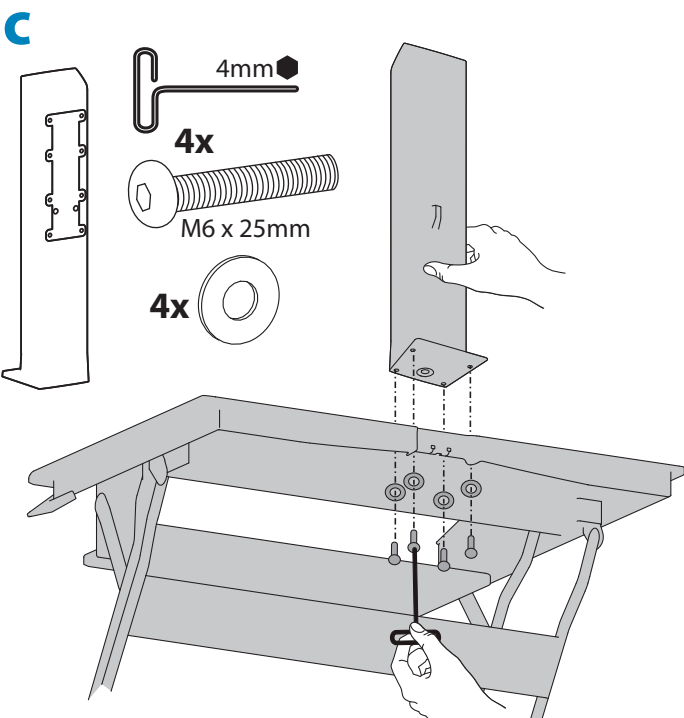
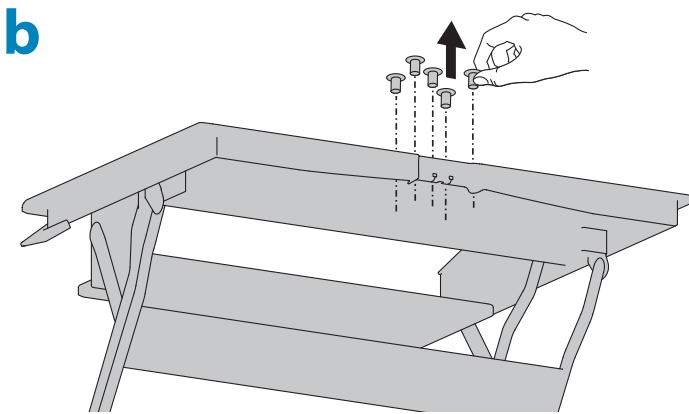
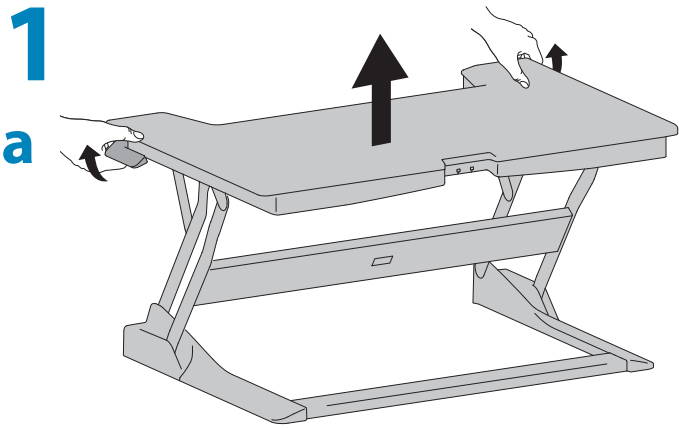

WorkFit-PD

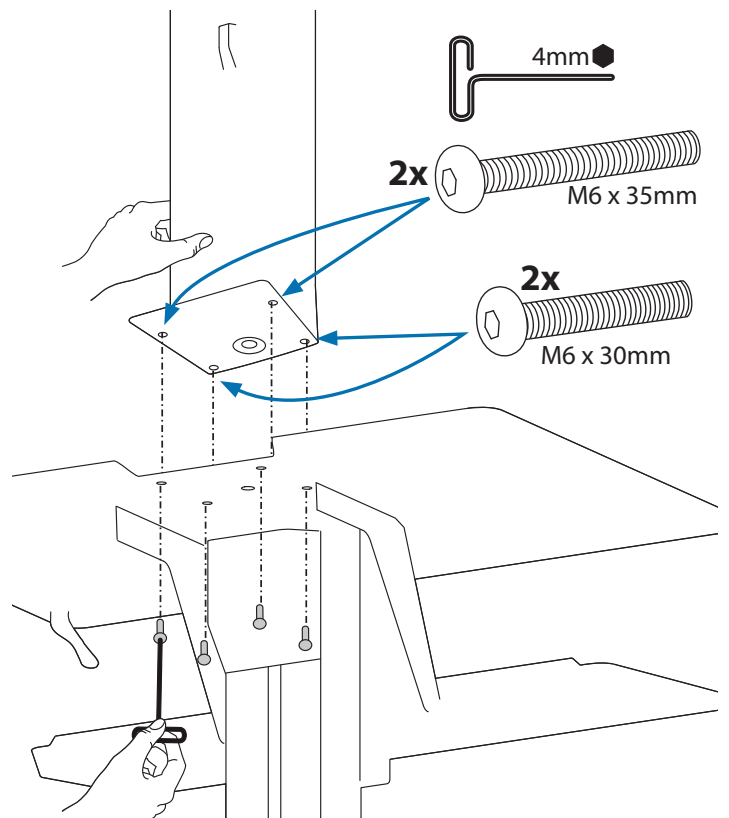
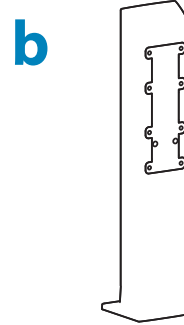
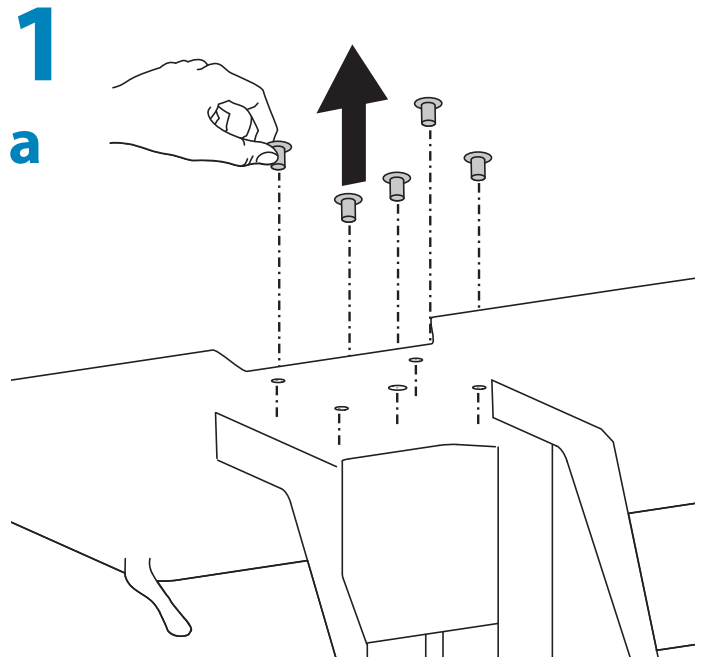

2

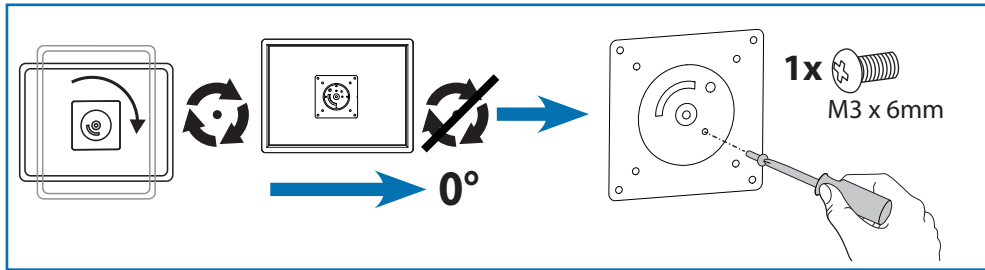
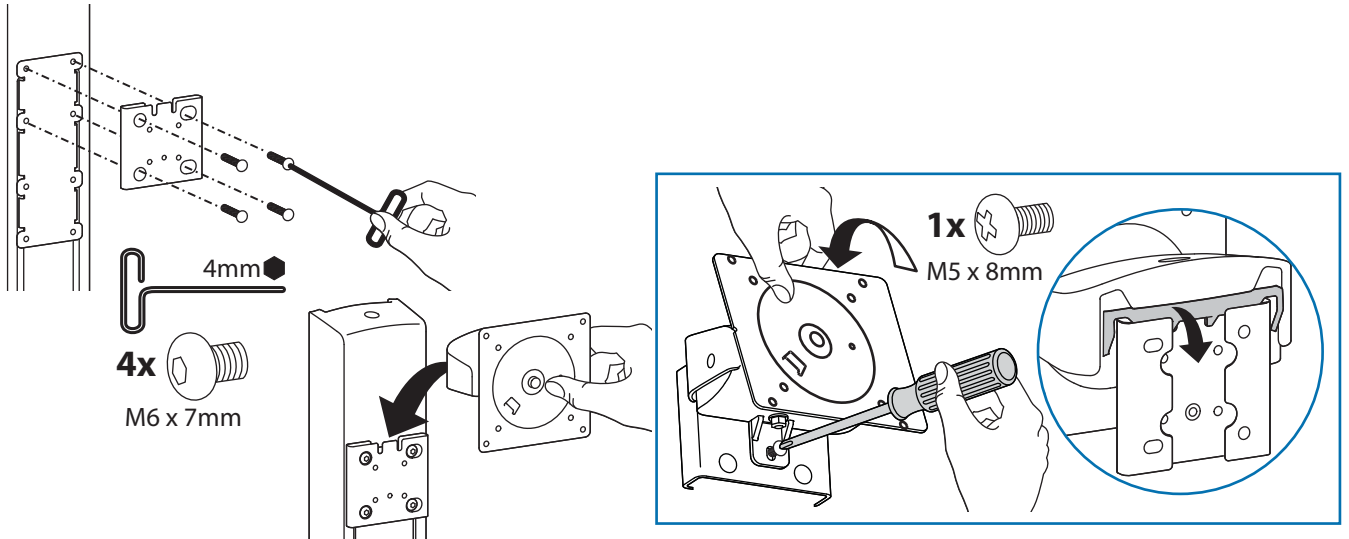

3

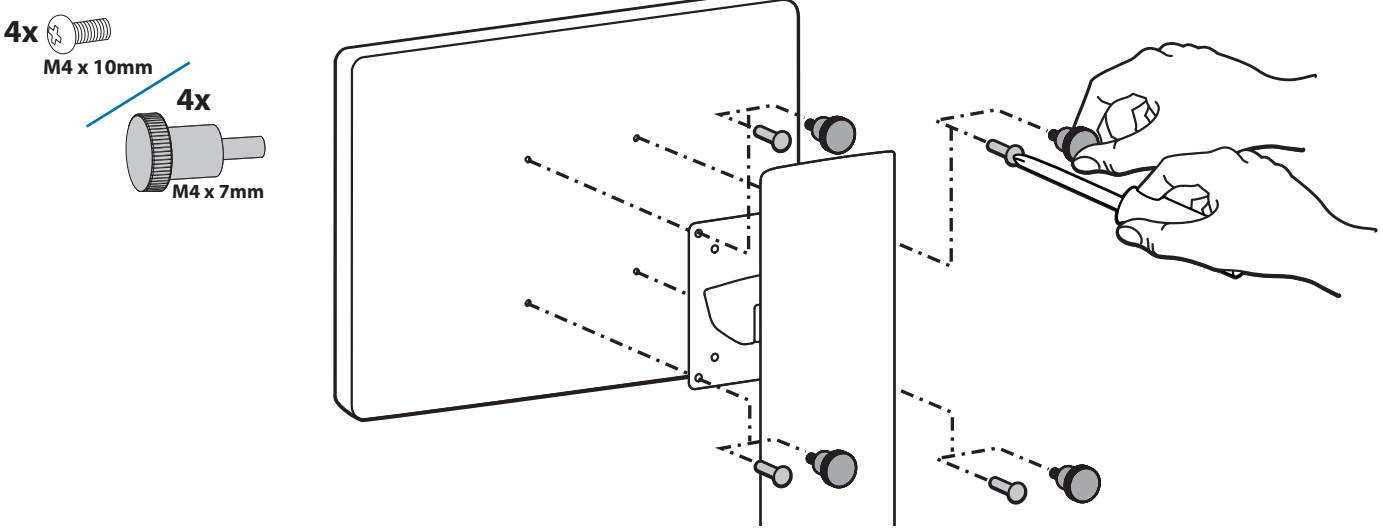

4

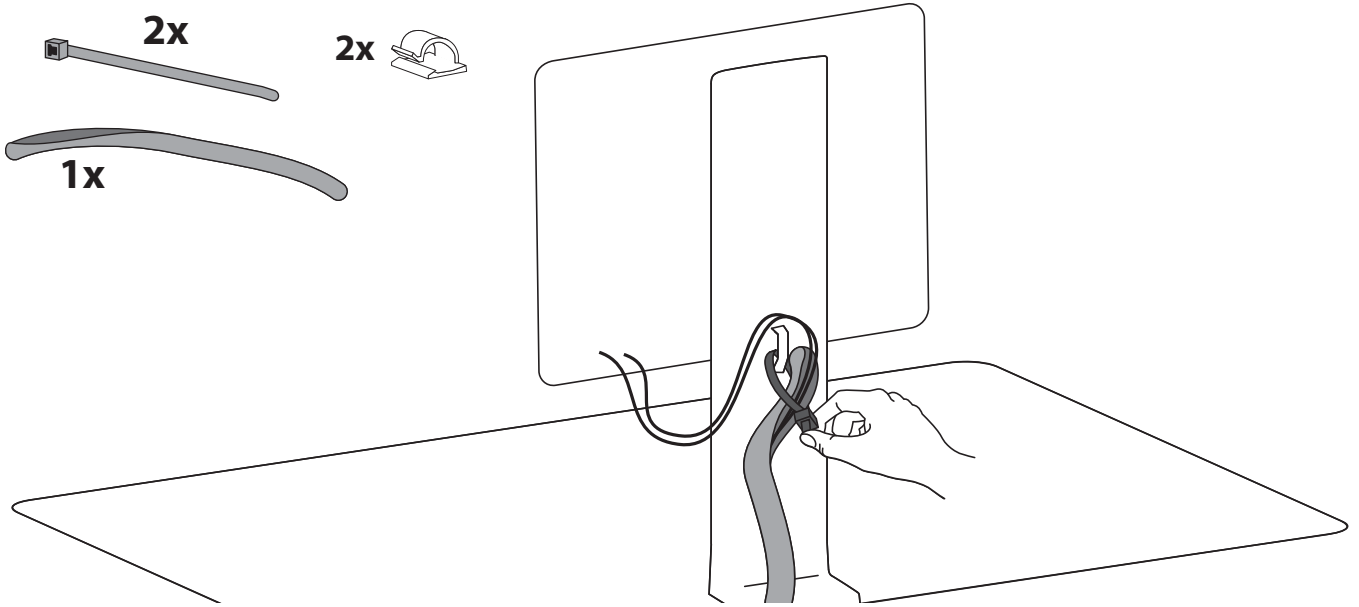

5 Adjustment Step

Important! You will need to adjust this product after installation is complete. Make sure all your equipment is properly installed on the product before attempting adjustments. This product should move smoothly and easily through the full range of motion and stay where you set it. If movements are too easy or difficult or if product does not stay in desired positions, follow the adjustment instructions to create smooth and easy movements. Depending on your product and the adjustment, it may take many turns to notice a difference. Any time equipment is added or removed from this product, resulting in a change in the weight of the mounted load, you should repeat these adjustment steps to ensure safe and optimum operation.

a

+ **LB kg**
Increase Lift Strength
 If the mounted weight is too heavy or this product does not stay up when raised, then you'll need to increase Lift Strength:

- **LB kg**
Decrease Lift Strength
 If the mounted weight is too light or this product does not stay down when lowered, then you'll need to decrease Lift Strength:

4mm

ENGLISH

b

+ **LB kg**
Increase Friction
 If this product moves too easily, then you'll need to increase friction:

- **LB kg**
Decrease Friction
 If this product is too difficult to move, then you'll need to decrease friction:

4mm

WorkFit-PD only

! WARNING IMPACT HAZARD

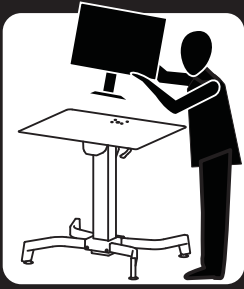

Moving Parts Can Crush And Cut!

Minimize Lift Tension BEFORE:

- Removing Mounted Equipment
- Shipping Cart or Storing Cart

To Minimize Lift Tension

1. With cart upright, lower worksurface to lowest position.
2. Turn adjustment nut at bottom of riser counterclockwise until it stops (Adjustment may require 40-60 revolutions):



Failure to heed this warning may result in serious personal injury or property damage!



Cart Must Remain Upright! Tipping Cart On Side May Cause the Work Surface to Disengage Causing Serious Personal Injury and Property Damage.

For More information and instructions refer to product guide at www.ergotron.com or contact Ergotron Customer Care at **1-800-888-8458**.

826-152-00

C

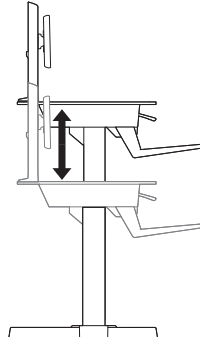

1

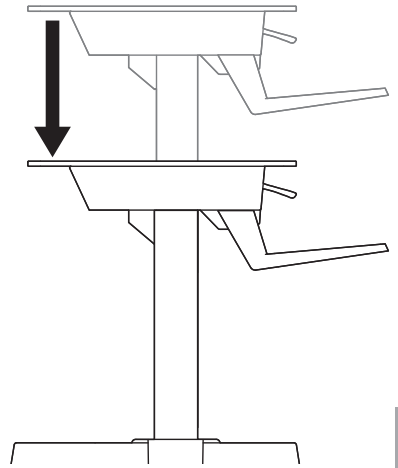

2



Increase Lift Strength

If the mounted weight is too heavy or this product does not stay up when raised, then you'll need to increase Lift Strength:



Decrease Lift Strength

If the mounted weight is too light or this product does not stay down when lowered, then you'll need to decrease Lift Strength:

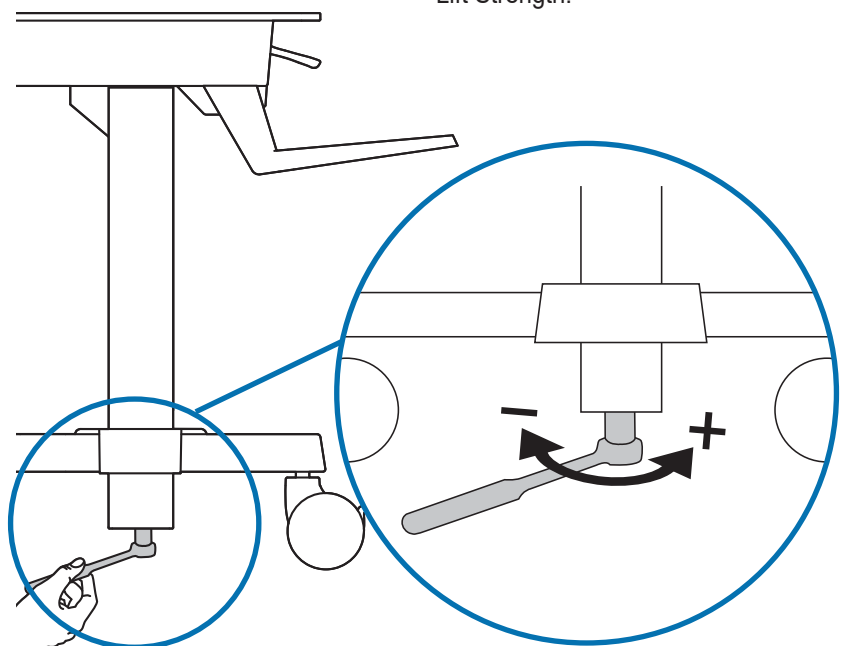

Set Your Workstation to Work For YOU!

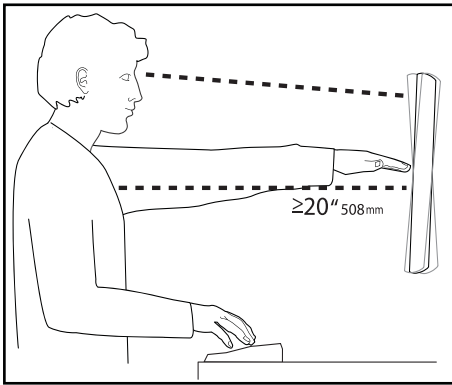

Learn more about ergonomic computer use at:
www.computingcomfort.org

- Height** Position top of screen slightly below eye level.
Position keyboard at about elbow height with wrists flat.
- Distance** Position screen an arm's length from face—at least 20" (508mm).
Position keyboard close enough to create a 90° angle in elbow.
- Angle** Tilt screen to eliminate glare.
Tilt the keyboard back 10° so that your wrists remain flat.

To Reduce Fatigue

- Breathe - Breathe deeply through your nose.
- Blink - Blink often to avoid dry eyes.
- Break • 2 to 3 minutes every 20 minutes
- 15 to 20 minutes every 2 hours.

For Warranty visit: www.ergotron.com/warranty

For Service visit: www.ergotron.com

For local customer care phone numbers visit: <http://contact.ergotron.com>

ERGOTRON®

Americas Sales and Corporate Headquarter	EMEA Sale	APAC Sale	Worldwide OEM Sales
St. Paul, MN USA (800) 888-8458 +1-651-681-7600 www.ergotron.com sales@ergotron.com	Amersfoort, The Netherlands +31 33 45 45 600 www.ergotron.com info.eu@ergotron.com	Tokyo, Japan www.ergotron.com apaccustomerservice@ergotron.com	www.ergotron.com info.oem@ergotron.com

© 2014 Ergotron, Inc. All rights reserved.

While Ergotron, Inc. makes every effort to provide accurate and complete information on the installation and use of its products, it will not be held liable for any editorial errors or omissions (including those made in the process of translation from English to another language), or for incidental, special or consequential damages of any nature resulting from furnishing this instruction and performance of equipment in connection with this instruction. Ergotron, Inc. reserves the right to make changes in the product design and/or product documentation without notification to its users. For the most current product information, or to know if this document is available in languages other than those herein, please contact Ergotron. No part of this publication may be reproduced, stored in a retrieval system, or transmitted in any form or by any means, electronic, mechanical, photocopying, recording or otherwise without the prior written consent of Ergotron, Inc., 1181 Trapp Road, Eagan, Minnesota, 55121, USA. Patents Pending and Patented U.S. & Foreign. Ergotron is a registered trademark of Ergotron, Inc.