

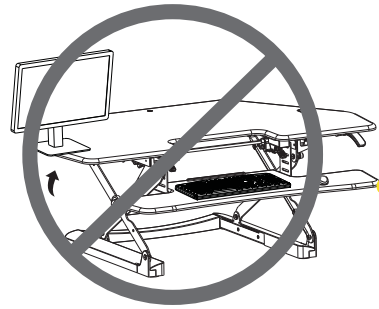

Do not place your hands near the strut during adjustment. The angle of the strut joints will change during the adjustment of the desktop height and it may hurt you.

Warning!



Please make sure all the devices are stably placed on the desktop. Do not exceed the edge of the desktop to prevent property damage or personal injury.

Caution!

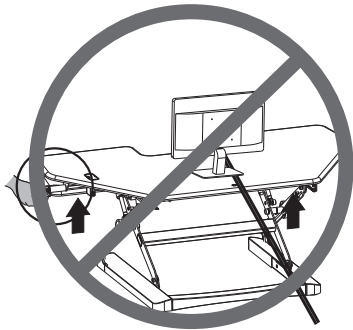

Do not tie the cable too tight. Allow the devices to move vertically to prevent property damage or personal injury.

Caution!

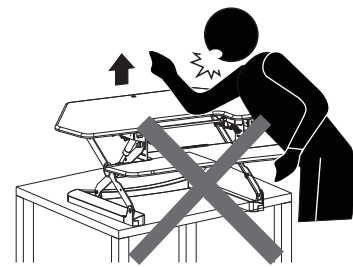

Lift the desktop to the top position before taking off the computer devices in order to prevent property damage or personal injury.

Warning!



The product must be moved by at least two people to avoid collision of moving parts and prevent property damage or personal injury.

Warning!

Loctek

— ERGONOMIC —

Model No.: LXC41

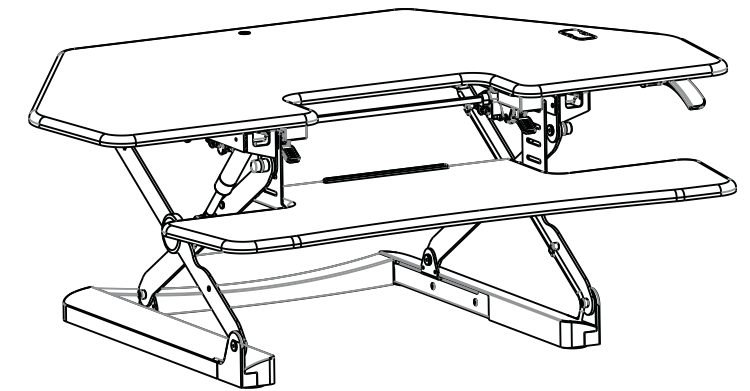
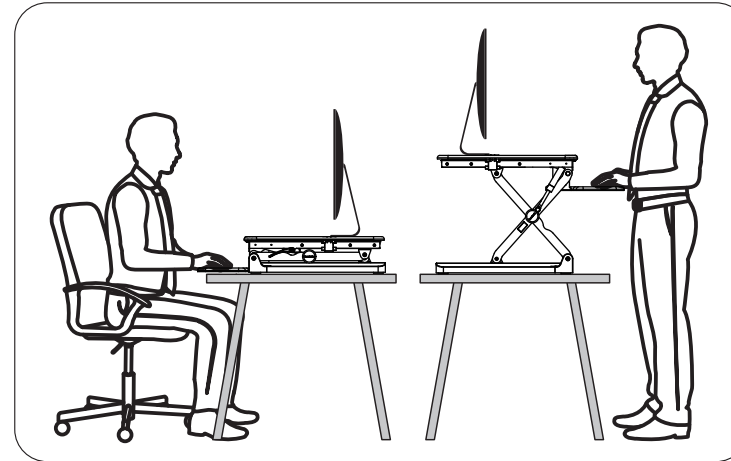

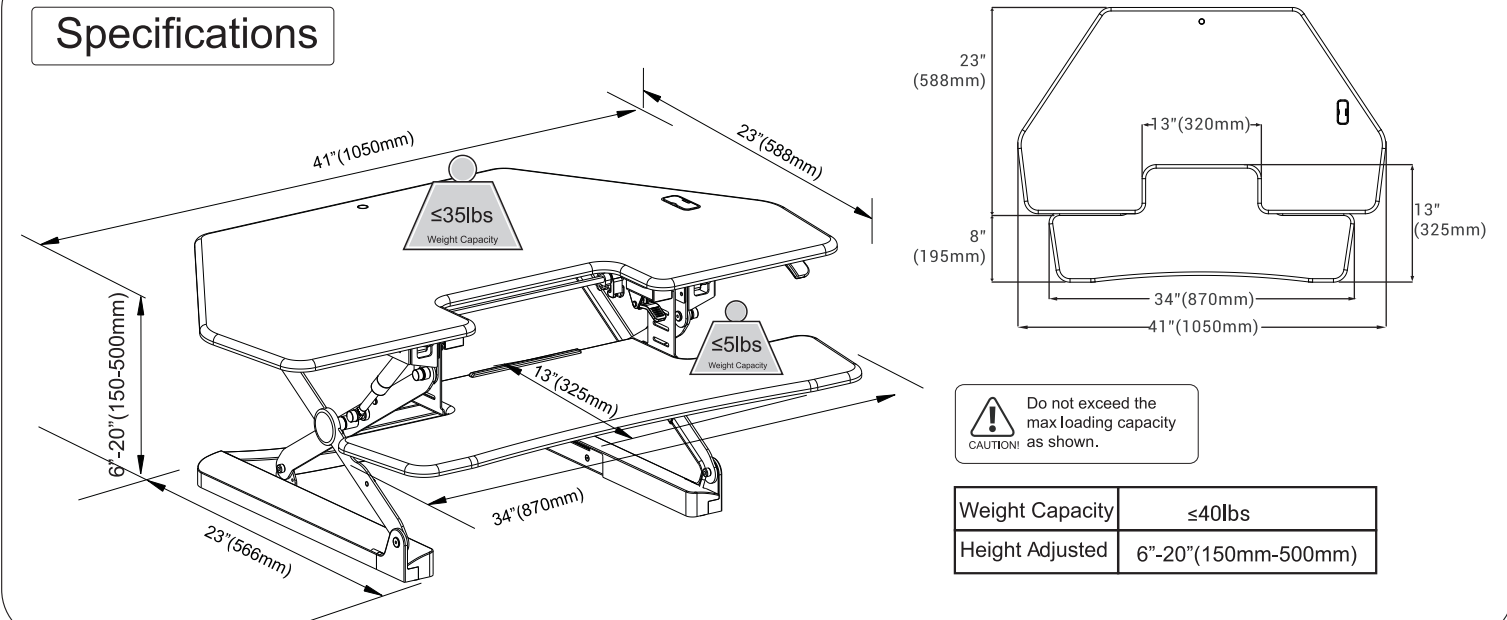

Specifications



Parts Included

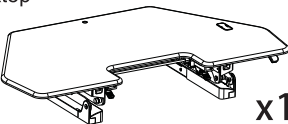
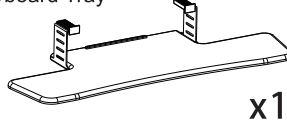

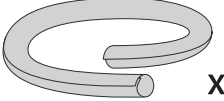
A	B	C
Desktop  x1	Keyboard Tray  x1	Cable Ties  x4
D	E	
Decorative Covers  x2	Cable Organizer  x1	

LOCTEK INC.

Address: 6475 Las Positas Rd, Livermore, CA 94551 United States

4290 Concorde Rd, Memphis, TN 38118 United States

Tel: 1-855-421-2808

Website: www.loctek.us

Step 1

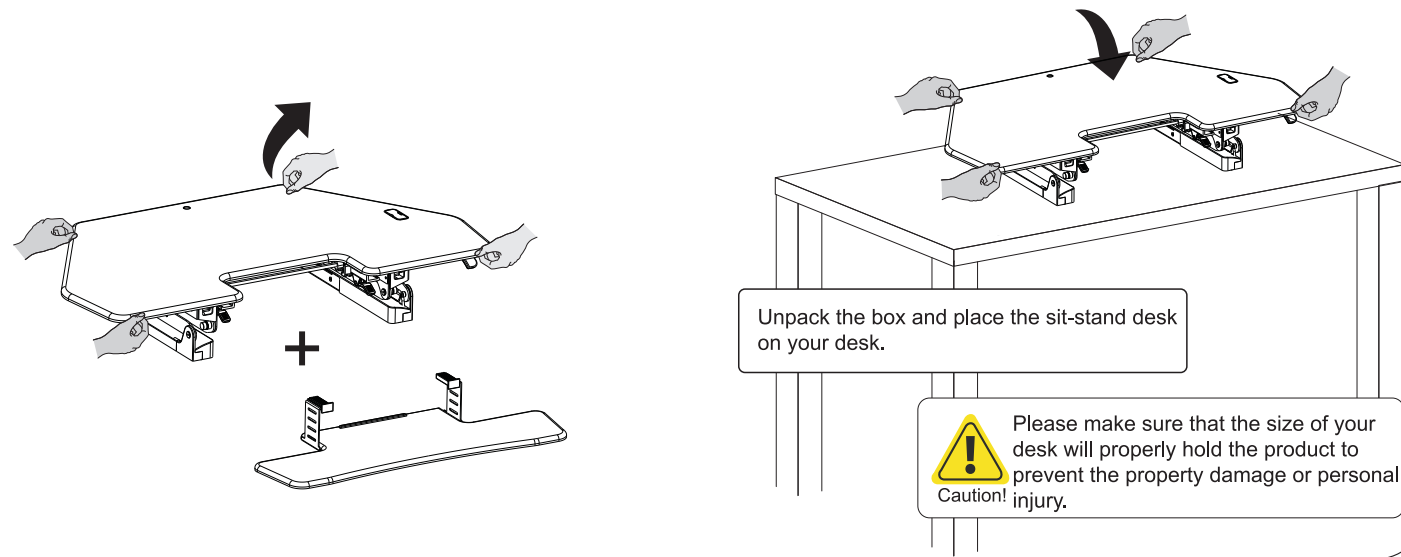

Step 2

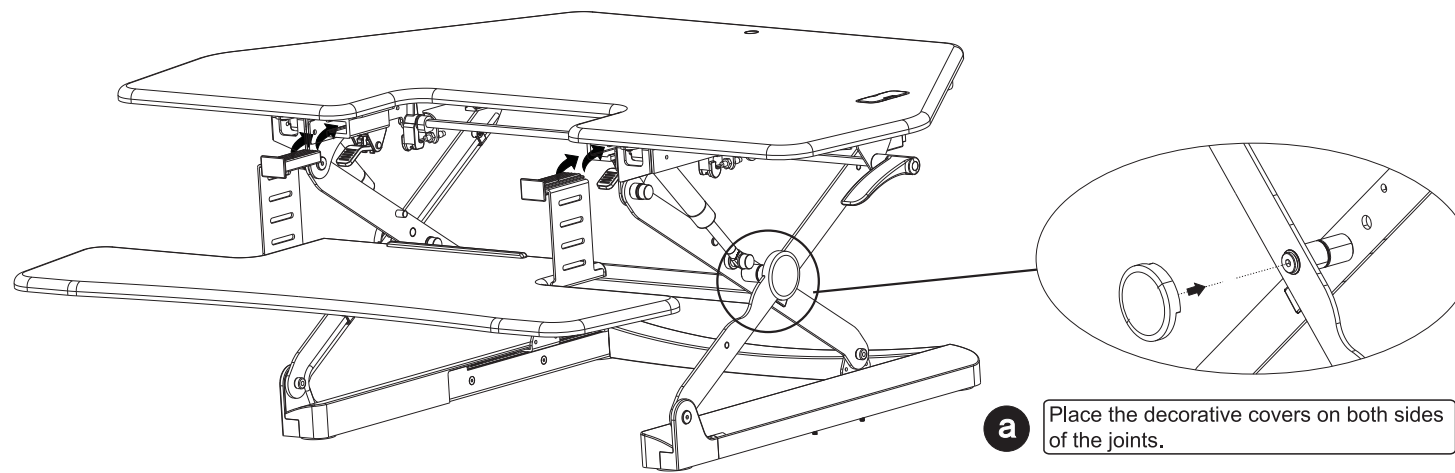

Install the connecting plates to the corresponding slide, and lock the levers.

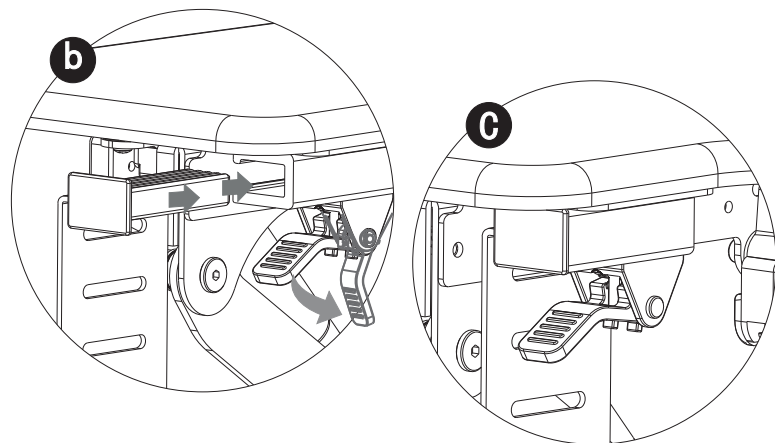

To remove the keyboard tray, unlock the levers. Caution!

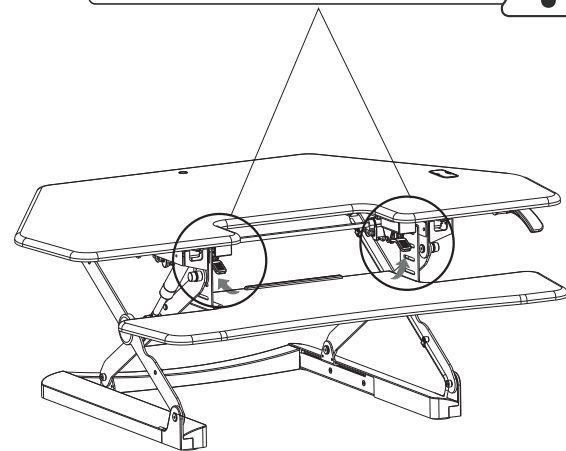

Step 3

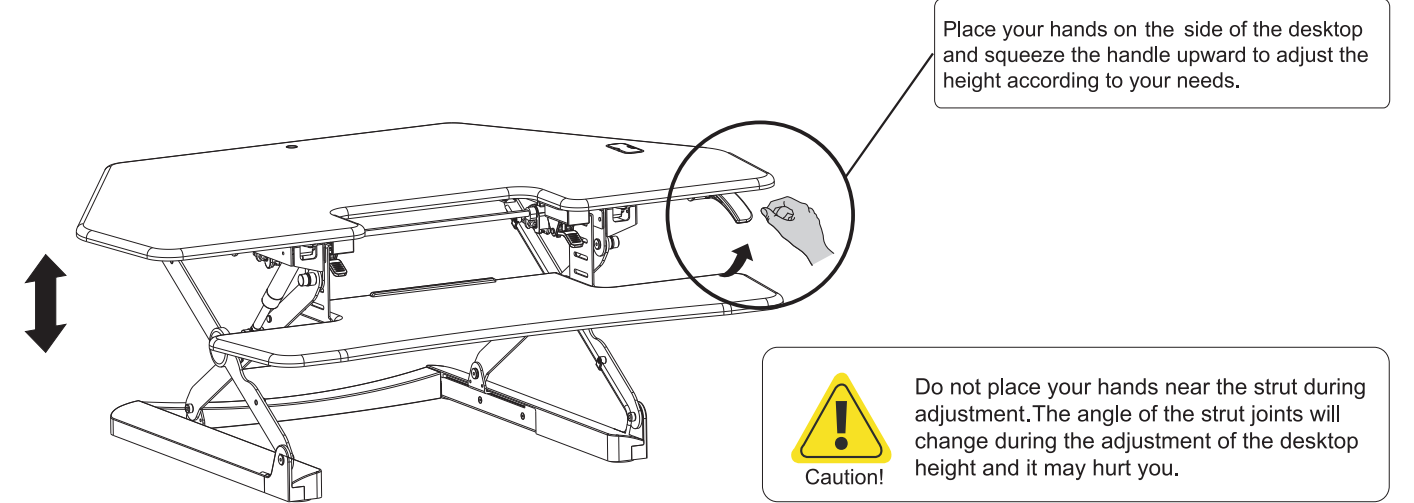

Step 4

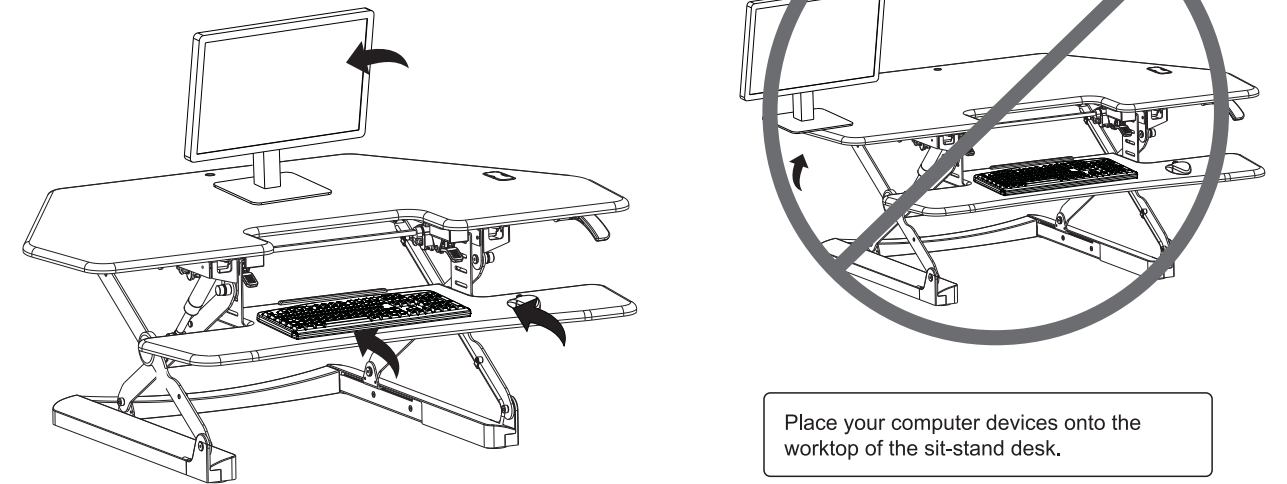

Step 5

