

# FLEXISPOT

**Model : M5B/M5W/M5N**

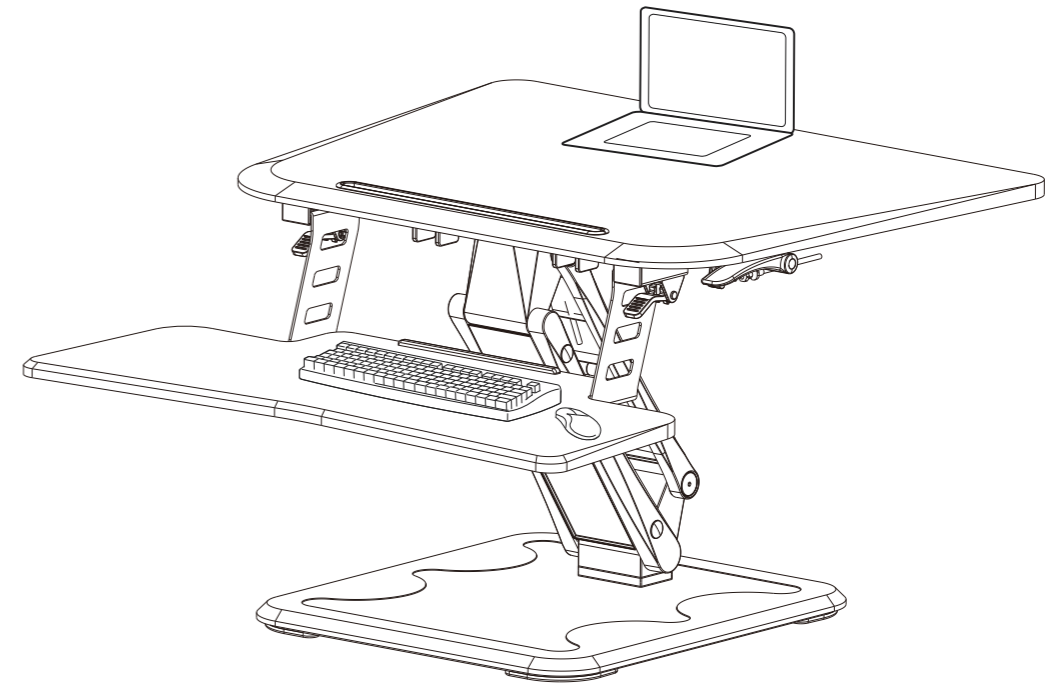





Installation Guide



Specifications	
Desktop Weight Capacity	≤ 33 lbs (15 KG)
Keyboard Tray Weight Capacity	≤ 4.4 lbs (2 KG)
Height Adjustable Range	6.7" - 17" (170 - 430mm)

## Parts Included:

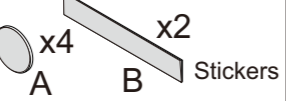
The diagram shown is for reference only and may not accurately depict all parts. Please contact customer service if there is any part missing.

Part#	Part Name	Qty	Part#	Part Name	Qty	Part#	Part Name	Qty	Part#	Part Name	Qty
①	 Desktop	1	②	 Keyboard tray	1	③	 Connecting Plates	1	④	 screws 8	8
⑤	 5x5 Hex Key	1	⑥	 x4 A x2 B Stickers		⑦	 Cable Sleeve x1				

Attach the connecting plate to the keyboard tray and tighten with 6pcs screws.

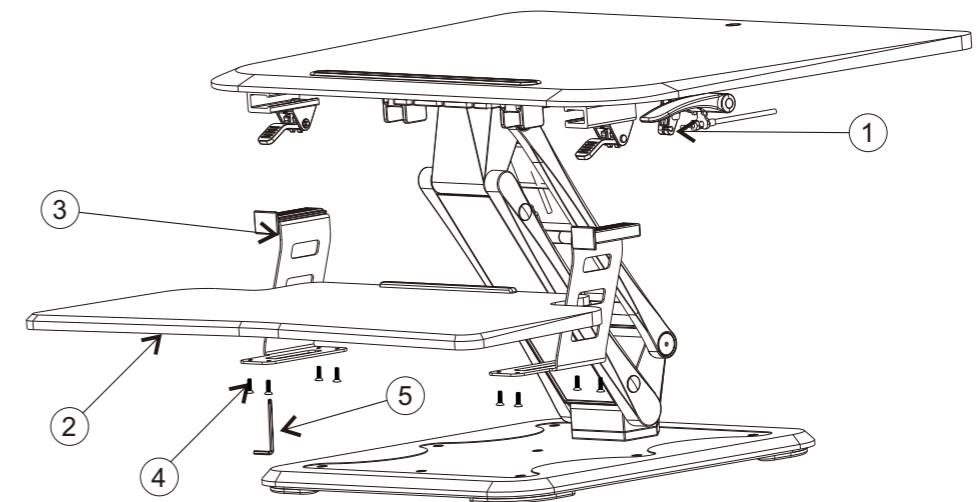
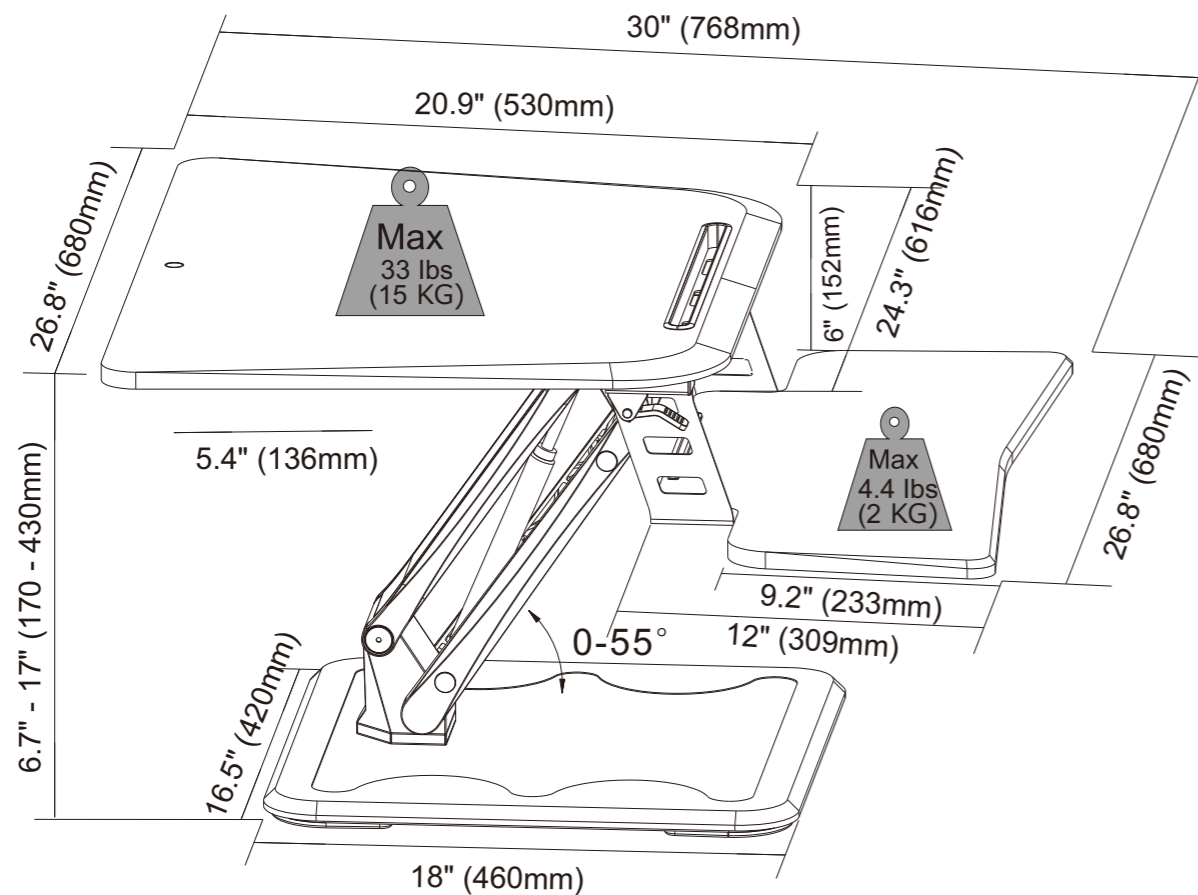

## Step 1: Place the desktop body on an even surface



Unlock the handle to release the main body part. Caution: Be careful when unlocking the handle because the surface will bounce up.

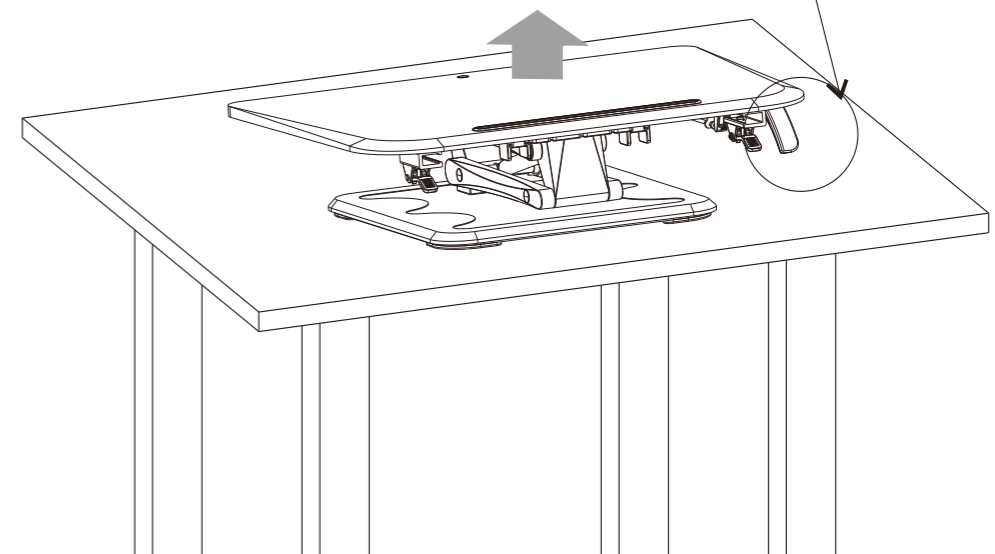

## Step 2: Connect the Keyboard Tray

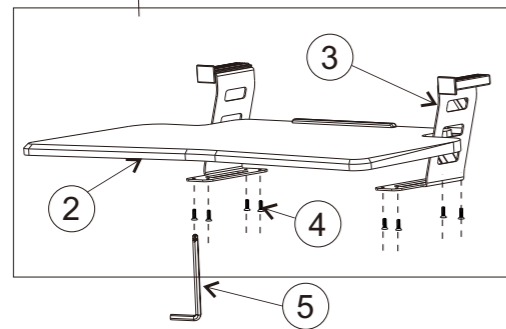
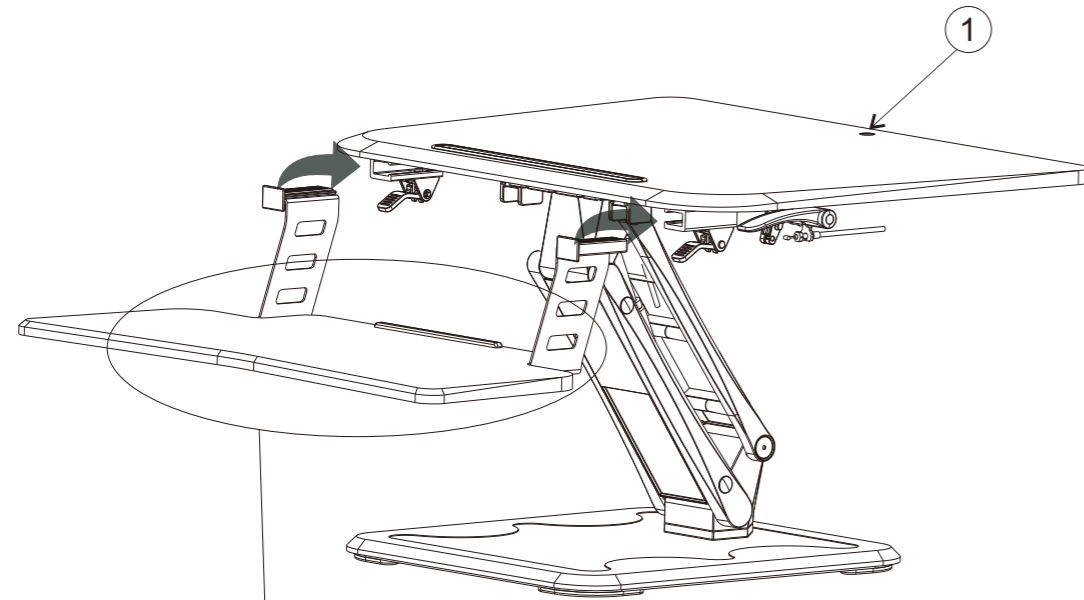

Attach the connecting plates to the keyboard tray and tighten with 8 screws.



Connect the keyboard tray (2) to the desktop plate.  
Note: The keyboard tray can be added or removed depending on your preference. It is not required for proper functioning of the unit.

Connect the keyboard tray to the desktop plate.

Unlock the handle grips on both sides then attach the keyboard tray as shown in the diagram. Lock the handle grips down to finish the assembly.

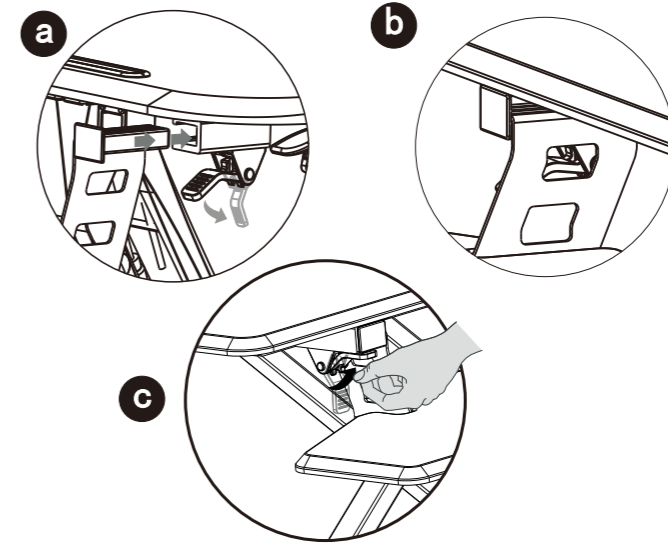

Remove the keyboard tray.

Please open the handle grips on both sides, then take out the keyboard tray.

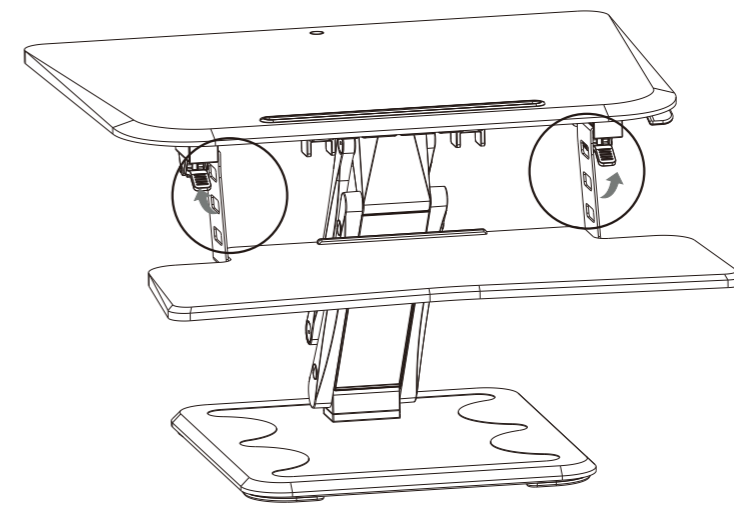

### Step 3: Place Your Devices Onto The Workstation

Press the handle grips on both sides simultaneously, and adjust the workstation to the proper height. The height adjustable range is 6.7" - 17" (170 - 430mm).

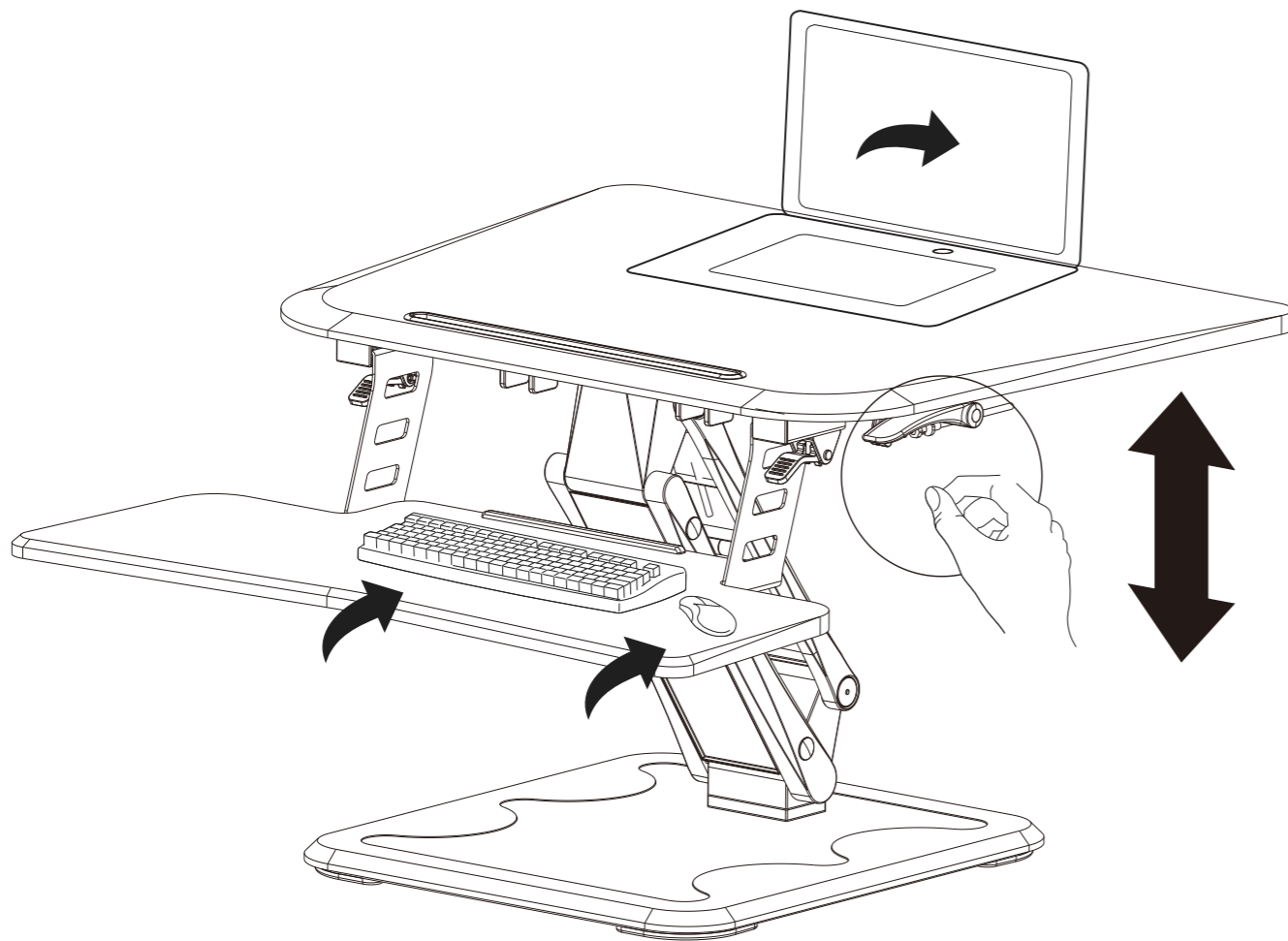

### Step 4: Use stickers to attach monitor to your desktop unit



Caution: Please make sure the desk surface is bigger than the base plate of the workstation. Failure to do so may result in damage to the device or physical injury.

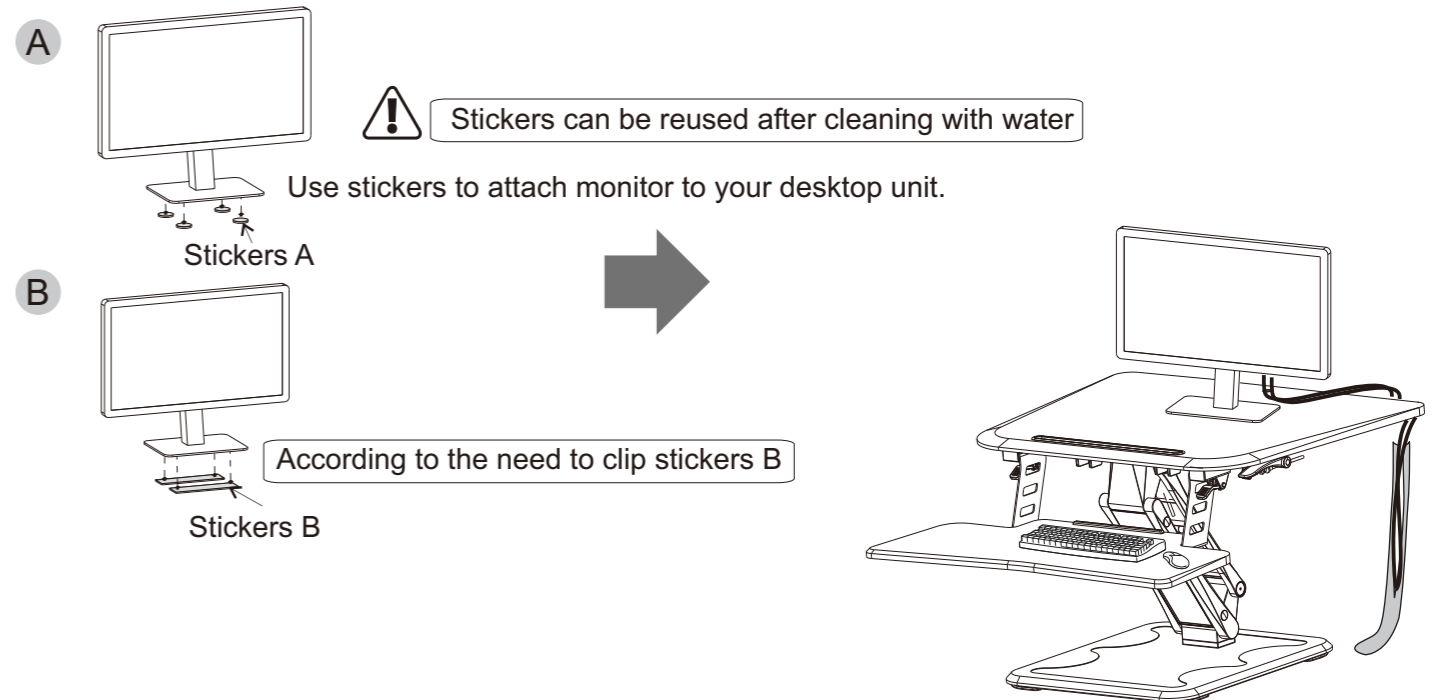
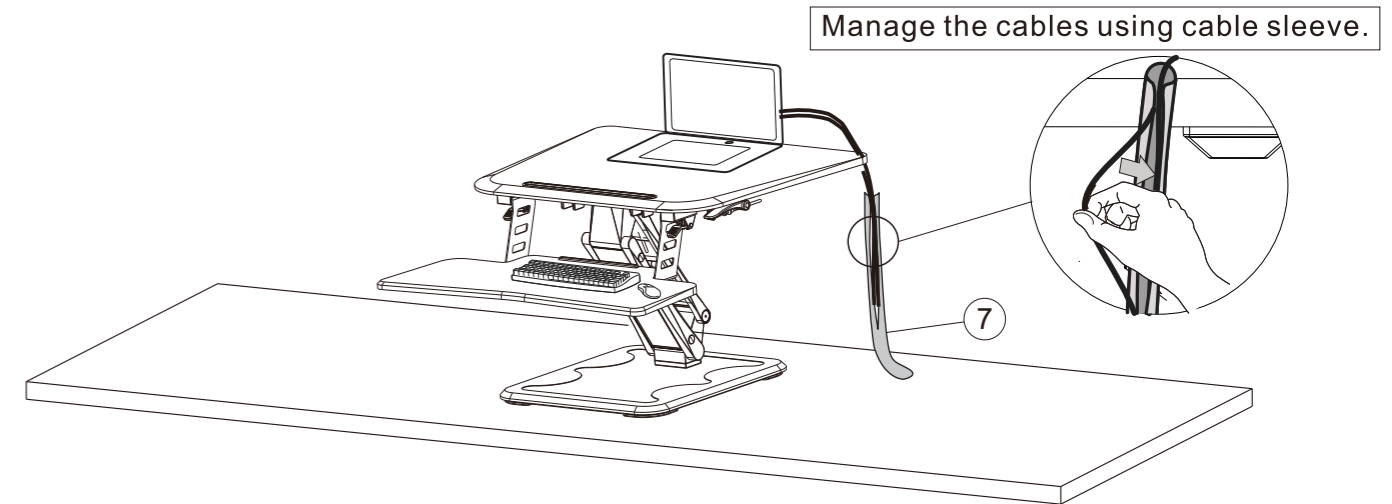

**Warning!**

This product contains small items that could be a choking hazard if swallowed. Keep these items away from young children.

- Make sure these instructions are read and completely understood before attempting installation. If you are unsure of any part of this installation, please contact a professional installer for assistance.
- Proper tools must be used. A minimum of two people are required for this installation. Failure to install properly can result in property damage or serious injury.
- Check joint parts every two months, making sure the screws have not loosened.

Note: This product is intended for indoor use only. Use of this product outdoors could lead to product damage or physical injury.

**WARNING**

Hand Pinching

Do not place your hands near the "scissor" part of the desk. The lifting mechanism will change when raising or lowering the desktop. Please be aware of all moving parts to avoid hurting your hands.



**Warning!**

Please do not place your hand near the scissor lift. The scissor lift angle will change when lifting or lowering the desktop and it may hurt your hands.



**Warning!  
No Climbing**



**Warning!**

Please make sure to install all equipment on a level surface.

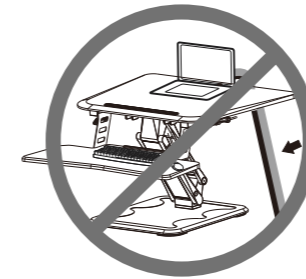

**Warning!**

Cable management tie is included to help organize your cables. When organizing cables, make sure you have sufficient cord length to reach the top height when the desktop unit is fully extended upwards. Failure to do so may result in damage to corded device.

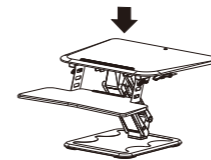

**Warning!**

If the device placed on your desktop weighs less than 6.6 lbs, press the handle grips and force down the desktop to prevent the workstation from bouncing up. Failure to do so may result in damage to the device or physical injury.



## FlexiSpot Limited Warranty

This limited warranty offered by FlexiSpot covers defects in material or workmanship in new FlexiSpot products. This warranty extends to the original purchaser only and is non-transferable. Only consumers purchasing FlexiSpot products from authorized FlexiSpot retailers or resellers may benefit from our limited warranty.

### What is Covered?

The FlexiSpot limited warranty covers our products against defects in material or workmanship as follows:

- FlexiSpot Height Adjustable Desk Frames

All height-adjustable desks purchased on or after October 5, 2016 include a 5-year warranty for the frame, and a 3-year warranty for the motor, controller and switch, electronics and other mechanisms.

- FlexiSpot Sit-Stand Desktop Workstations

All standing desks purchased on or after October 5, 2016 include a 5-year warranty for the frame, medium-fiber desktop, and a 3-year warranty for the gas spring system and other mechanisms.

- FlexiSpot Desk Bikes

All desk bikes purchased on or after October 5, 2016 include a 3-year warranty for the frame, and a 1-year warranty for the electronics and other mechanisms.

- FlexiSpot Mini Steppers

All desk bikes purchased on or after October 5, 2016 include a 1-year warranty for the frame, and other mechanisms.

- Accessories

All monitor mounts purchased on or after October 5, 2016 include a 5-year warranty for the arms, and 3-year warranty for gas spring system and mechanisms.

### What are your Remedies?

FlexiSpot will replace at no charge to the consumer the defective parts only or, at FlexiSpot's option, replace any product or part of the product that is defective because of improper workmanship and/or material, under normal installation, use, service and maintenance. If FlexiSpot is unable to provide a replacement and repair is not practical or cannot be completed in a timely fashion, FlexiSpot may elect to refund the purchase price in exchange for the return of the product. In the rare event that your FlexiSpot product is defective, we will provide you with a replacement item shipped at no cost to you within the continental United States. The shipping method for replacement products is FedEx Ground, but expedited shipping is available if you choose to pay the additional expense. In addition, you will need to pay the shipping costs if any products need to be shipped to you at an address outside the continental United States.

**REPAIR OR REPLACEMENT (OR, IN LIMITED CIRCUMSTANCES, REFUND OF THE PURCHASE PRICE) AS PROVIDED UNDER THIS WARRANTY IS THE EXCLUSIVE REMEDY OF THE PURCHASER. FLEXISPOT NEITHER ASSUMES NOR AUTHORIZES ANY PERSON TO CREATE FOR IT ANY OTHER OBLIGATION OR LIABILITY IN CONNECTION WITH THIS PRODUCT.**

## FlexiSpot Limited Warranty

### What is Not Covered?

Our limited warranty does not cover any problem that is caused by:

1. Conditions, malfunctions or damage not resulting from defects in material or workmanship.
2. Conditions, malfunctions or damage resulting from normal wear and tear, improper installation, improper maintenance, misuse, abuse, negligence, accident or alteration.
3. Accessories, connected materials and products, or related products not manufactured by FlexiSpot.
4. Conditions, malfunctions or damage resulting from failure to follow the instructions and guidelines relating to the product's intended use.

Our limited warranty is void if a product is returned with removed, damaged or tampered labels or any alterations (including removal of any component or external cover).

### How to File a Claim?

In order to receive the benefit of our limited warranty, you need to process your claim in compliance with the terms of this limited warranty and follow proper return procedure. To request warranty service, please contact customer service via email at [contact@FlexiSpot.com](mailto:contact@FlexiSpot.com) or toll free at 855-421-2808. You will need to provide the sales receipt or other evidence of the date and place of purchase for your FlexiSpot product.

### Implied Warranties and Limitation of Damages

**EXCEPT TO THE EXTENT PROHIBITED BY APPLICABLE LAW, ALL IMPLIED WARRANTIES (INCLUDING WARRANTIES OF MERCHANTABILITY AND FITNESS FOR A PARTICULAR PURPOSE) SHALL BE LIMITED IN DURATION TO THE DURATION OF THIS WARRANTY, AND FLEXISPOT SHALL NOT BE LIABLE FOR ANY INCIDENTAL, INDIRECT, SPECIAL, OR CONSEQUENTIAL DAMAGES, INCLUDING BUT NOT LIMITED TO LOSS OF PROFITS OR REVENUE, RESULTING FROM ANY BREACH OF EXPRESS OR IMPLIED WARRANTY OR CONDITION, OR UNDER ANY OTHER LEGAL THEORY, EVEN IF FLEXISPOT HAS BEEN ADVISED OF THE POSSIBILITY OF SUCH DAMAGES.** Some jurisdictions do not allow limitations on the duration of an implied warranty or the exclusion or limitation of special, indirect, incidental or consequential damages, so the above limitations or exclusions may not apply to you.

### Governing Law

This Warranty shall be governed by the laws of the State of California, USA, without giving effect to any conflict of laws principles that may provide the application of the law of another jurisdiction.

### How State Law Applies

This Warranty gives you specific legal rights, and you may also have other rights which vary from state to state.