

30" x 19" Sit-Stand Desktop Workstation

Instruction Manual

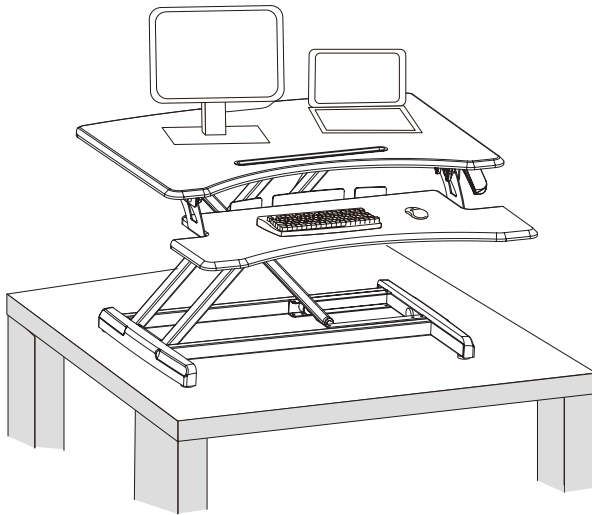

SKU: DESK-V000M



Scan the QR code with your mobile device or follow the link for helpful videos and specifications related to this product.

<https://vivo-us.com/products/desk-v000m>



help@vivo-us.com



www.vivo-us.com



1-800-371-5654

⚠ WARNING!

If you do not understand these directions, or if you have any doubts about the safety of the installation, please call a qualified technician. Check carefully to make sure there are no missing or defective parts. Improper installation may cause damage or serious injury. Do not use this product for any purpose that is not explicitly specified in this manual and do not exceed weight capacity. We cannot be liable for damage or injury caused by improper mounting, incorrect assembly or inappropriate use.

PACKAGE CONTENTS



A (x1)
Adjustable
Desktop



B (x2)
Keyboard
Hinge



C (x1)
Keyboard
Tray



D (x6)
Screw



E (x2)
Cable Tie

TOOLS NEEDED



Phillips
Screwdriver

**⚠ WARNING
PINCH POINT**

DO NOT place hands on or near support bars. Moving parts can crush and cut. Pinch points are created during lifting and lowering the worksurface. Failure to follow these instructions may result in serious personal injury.



DO NOT EXCEED WEIGHT CAPACITY.
Failure to do so may result in serious injury.



ASSEMBLY STEPS

STEP 1

Carefully remove desk frame and contents from packaging. Remove straps from desktop (A).

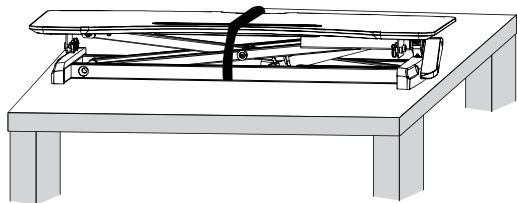

STEP 2

Screw keyboard hinges (B) onto keyboard tray (C), using screws (D).

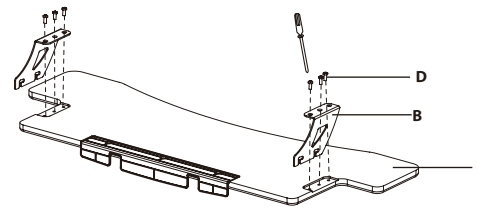

Screw assembled keyboard tray and hinges (B) onto adjustable desktop.

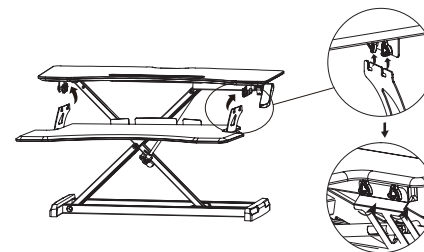

STEP 3

Squeeze the handle on the right side, then raise or lower desktop to desired height.

Place monitor and other items on desktop and manage cables using cable ties (E).

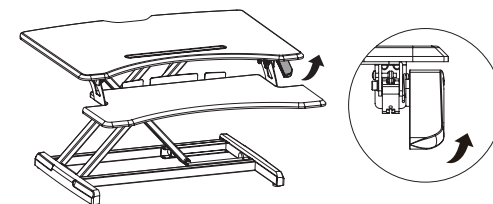

⚠ CAUTION!



Keep monitor and laptop base fully on the desktop.

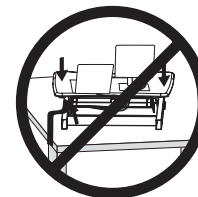

Follow the cable routing instructions to avoid the potential to pinch cables.



Leave enough slack in cable to allow for full range of vertical motion (15" / 38 cm).



Raise desktop slowly to keep items stable.

Failure to follow these instructions may result in property damage and/or personal injury.



Love your new VIVO setup and want to share?

Tag us in your photo! **@vivo_us**

Last Updated: 11/09/2018



If any parts are received damaged or defective, please contact us. We are happy to replace parts to ensure you have a fully functioning product.



help@vivo-us.com



www.vivo-us.com



1-800-371-5654

For more VIVO products, check out our website at:
www.vivo-us.com.