

LifeSpan Workplace

C3-DT3
Under Desk Bike



*Desk not included

DISPLAY READOUTS Pedaling time, level, calories, distance, and speed

RESISTANCE LEVELS 16

SEAT ADJUSTMENT 19 levels

WARRANTY

FRAME Lifetime

PARTS 2 Years

LABOR 1 Year



LifeSpan Workplace

www.LifeSpanFitness.com | 877.654.3837 option 2

Contact a Sales Specialist for further assistance
in space planning at 877.654.3878 Option 2.

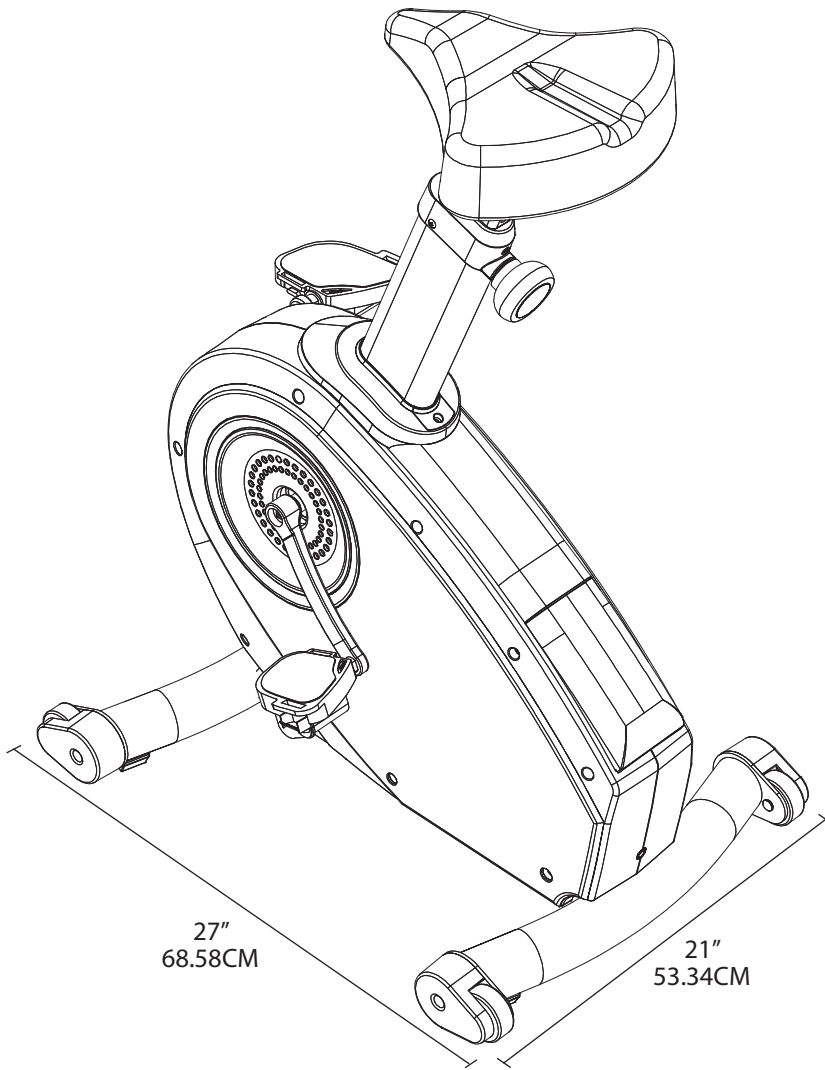

PRODUCT **C3-DT3**

COLORS

COVERS



PANTONE®
431 C

FRAME



PANTONE®
877 C

DIMENSIONS

BIKE 27" L x 21" W x 36.5" to 46.5" H
68.58CM x 53.34CM x 92.7CM to 118.1CM

WEIGHT

BIKE 94 LBS/42.64 KG
CONSOLE 3 LBS/1.36 KG

36.5" to 46.5"
92.7CM to 118.1CM

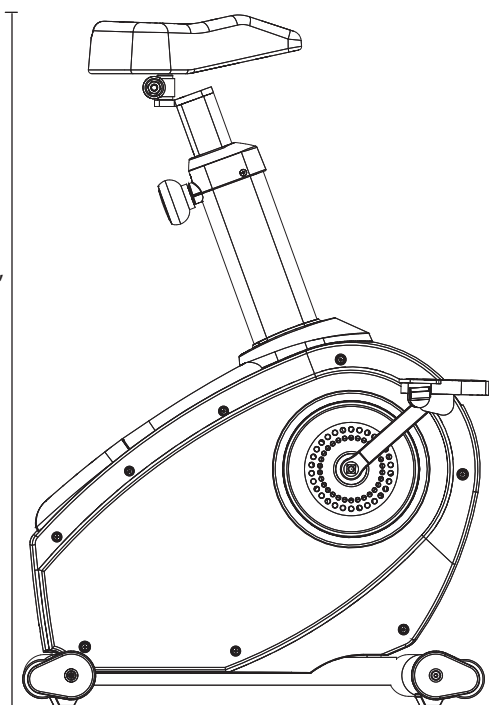

27"
68.58CM

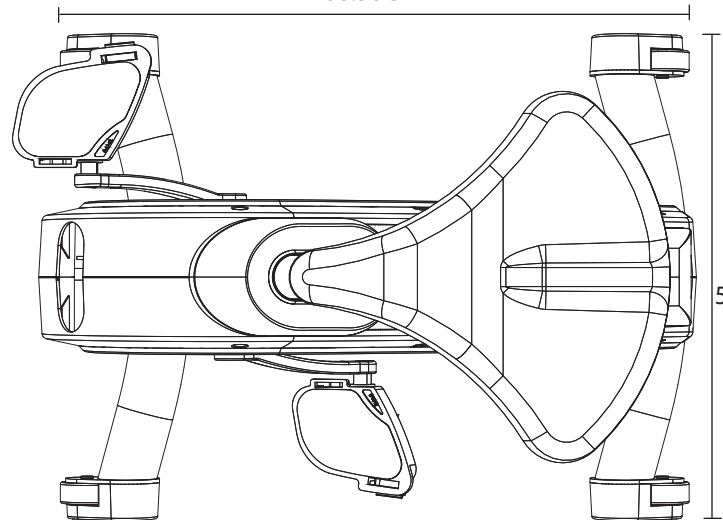

21"
53.34CM

*DESK NOT INCLUDED WITH THIS MODEL