

Diagram

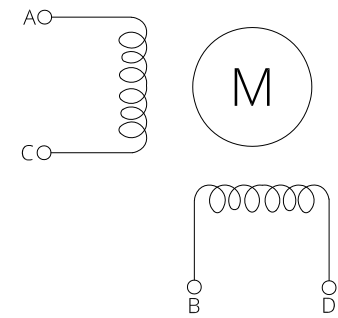

Items	Specification	Items	Specification
Phase Number	2	Step Angle	1.8° ± 5%
Rated Voltage	DC 3.3V / Phase	Rated Current	DC 1.4A / Phase
Phase Resistance	2.4x(1±10%) Ω	Phase Inductance	5.5x(1±20%) mH
Holding Torque	230mN-m MIN	Detent Torque	15 mN-m REF.
Rotation Direction	A-AB-B CW	Insulation Resistance	100Mohm(DC500V)
HI-POT	AC600V/1mA/1S	Insulation Class	Class B 130°C
Rotor Inertia	32 g-cm <sup>2</sup> REF.	Weight	0.15 Kg REF

VIEW

SCALE: NA

**LDO Motors Co., Ltd.**

Part NO. **1.8° NEMA17 Stepper Motor**

DRAWN BY	CHECKED BY	APPR. BY	DATE	FACTORY CODE	SHEET NO.
					1/1