

Pro CC Linkage Kit

Install Instructions

Fits all 2019+ POLARIS INDY PRO-CC
128-129/136-137 Rear Suspensions

Item	Description	Qty
1	PRO-CC Link Rods	1
2	PRO-CC Cam	1
3	Locknut	1
4	Reducer Pin	1
5	Hex Head Bolt	1
6	Mid Bearing	2
7	Mid Grease Seal	2
8	Lower Bearing	2
9	lower Grease Seal	2

PN# 73-35-042-R

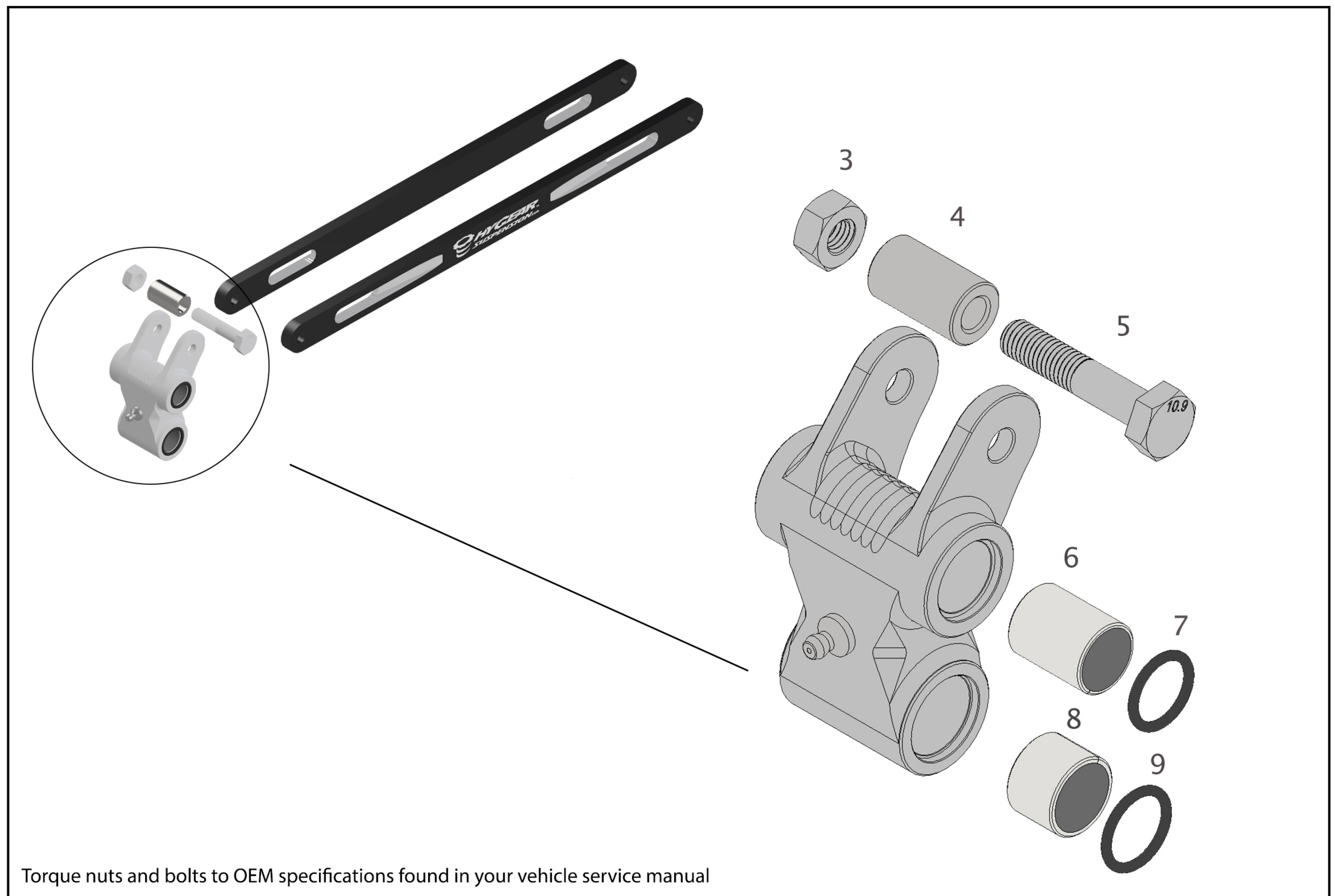

Torque nuts and bolts to OEM specifications found in your vehicle service manual



Important! Read all instructions carefully and double check your work. Failure to follow instructions may result in damage to suspension components. After installation is complete be sure to cycle the suspension through it's motion. We are not responsible for any damage that can occur from improper installation. We are not responsible for any damage that can occur from wear to shock surfaces or related components.

73-35-042-R 7/2024 SH

If in doubt, just ask!



- This is a progressive rate linkage system that installs directly in place of the OEM, Link and Link rods. No modifications to frame and chassis are needed. All idler wheels will maintain their original factory position.

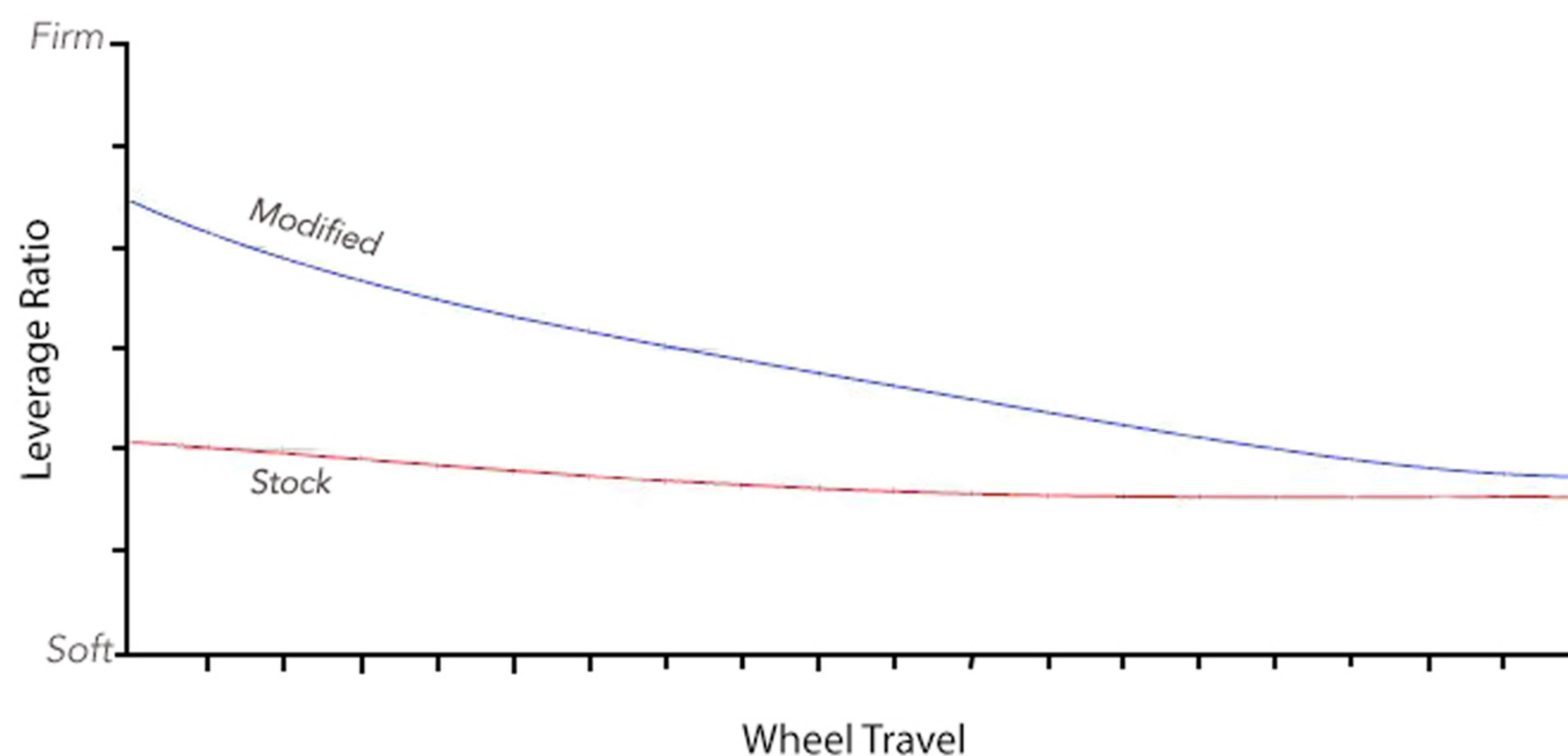

- The Pro CC Linkage incorporates a rising rate motion ratio designed to enhance ride comfort and feel when using stiffer shock calibrations. For optimal performance it's recommended to use a stiffer calibration designed for progressive rate motion. Sold Separately.

- Compatibility with All 2019+ POLARIS INDY PRO-CC 128-129/136-137 Rear Suspensions

***Note** -128/129 applications require 73-35-043-R Gullwing Bracket. This is needed to add clearance for the cam pivot. Sold Separately.

- There are multiple ways to install the linkage. The following steps show the linkage system being installed with the rear suspension mounted in the vehicle.



308 Peruville Rd. Freeville, NY 13068

If in doubt, just ask!

info@hygearsuspension.com

Page 2 of 6

We always recommend taking photos of your stock suspension to reference before removal of any components. Start by removing idler wheels or components that may interfere with access to mounting hardware.

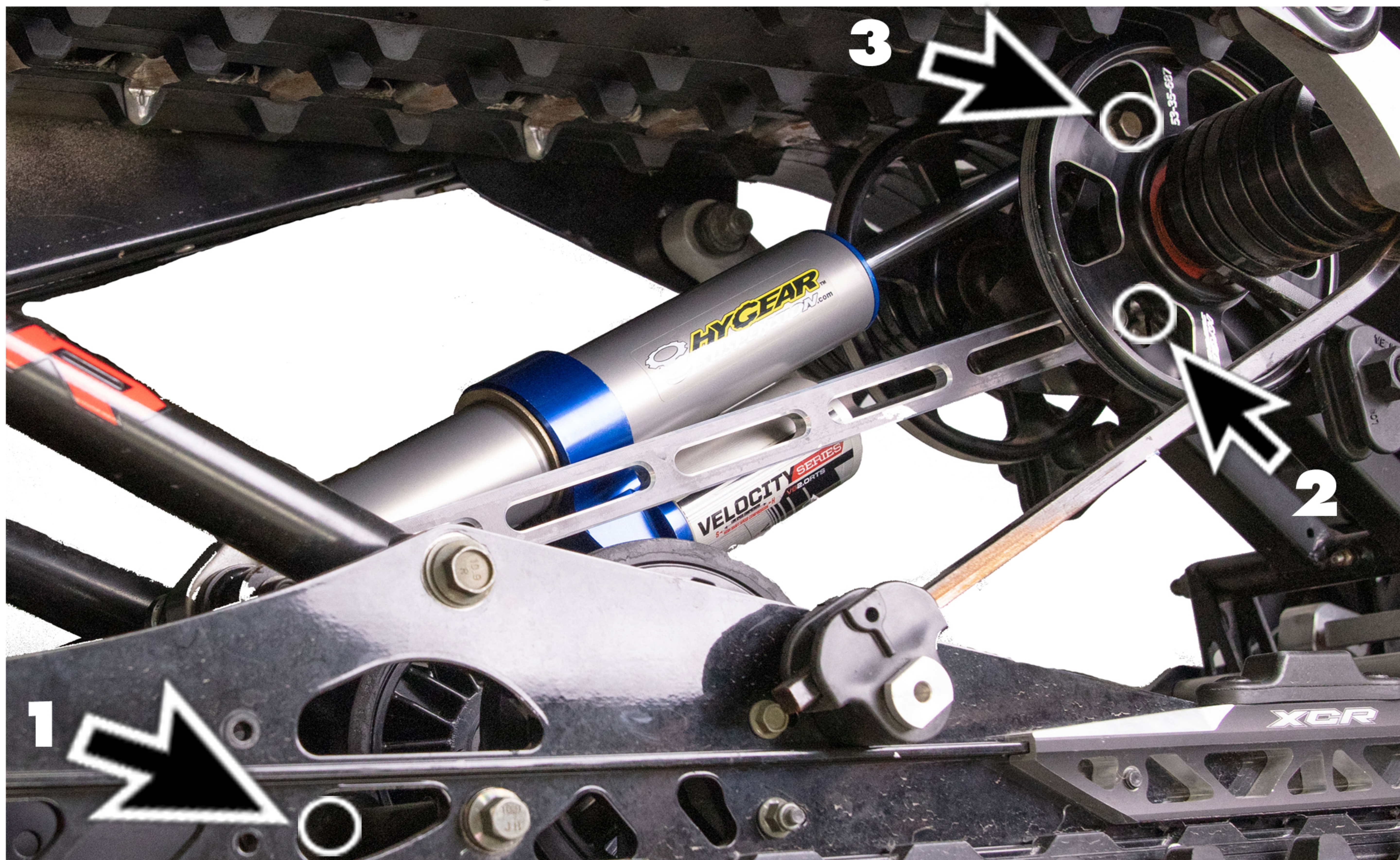

To remove the OEM linkage and shock assembly start by removing mounting bolts in the order of: 1,2,3 as shown.



Note* Some images in this instruction may display larger diameter rear arm idler wheels. These are not required for installation.



The rear arm idler wheels have access holes to remove the rear shock mount and link rod pivot bolts.



Remove the OEM shock and link rod assembly from the rear suspension.

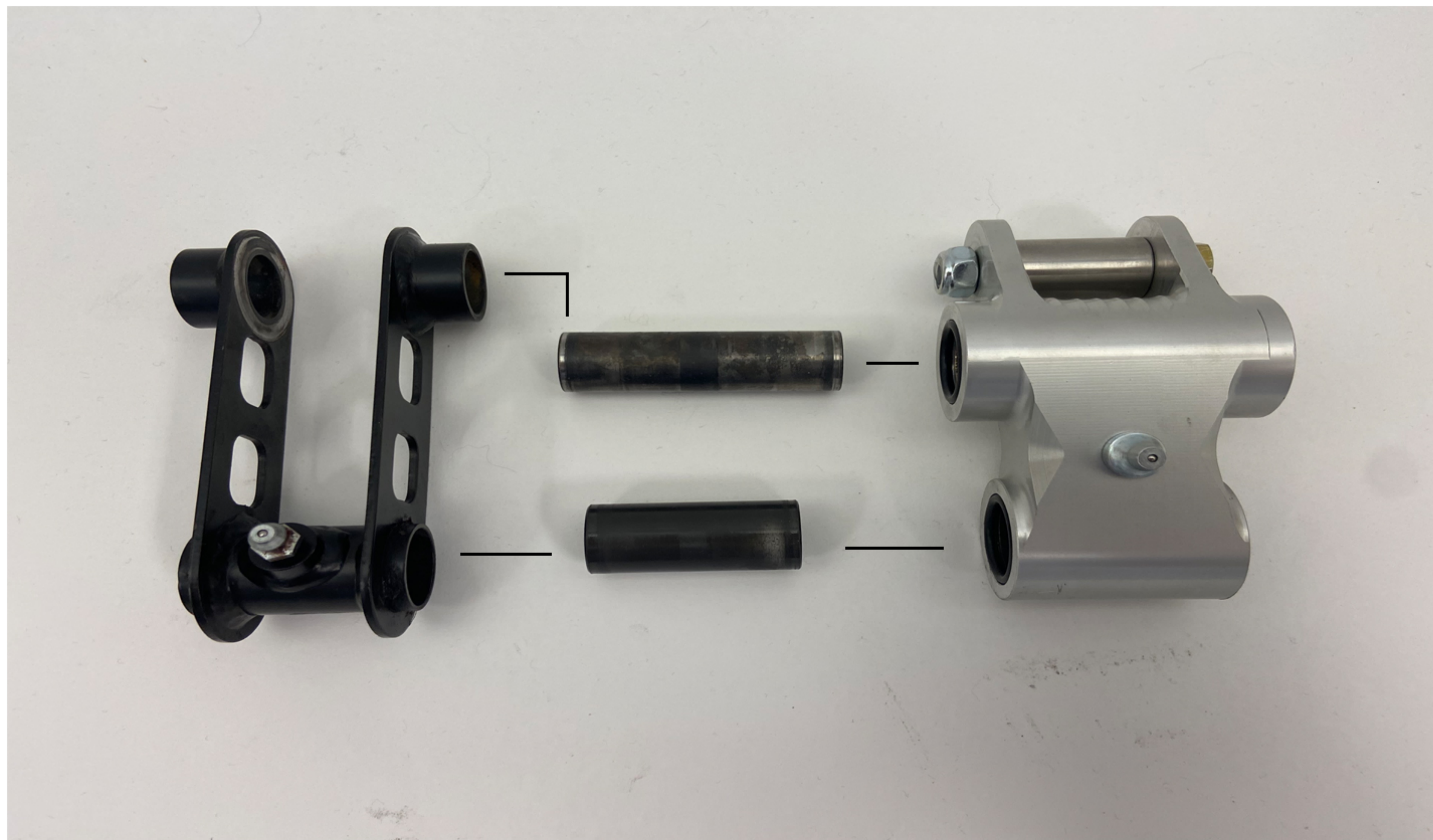

Reuse the two mounting pins from the OEM link. Install both into the cam and ensure the O-ring seals are properly seated.



Note the shock mounting orientation and the direction of logo placement on the link rods for proper assembly before installing back into the suspension.



Start by installing mounting bolts in the order of: 1, 2, 3 as shown.

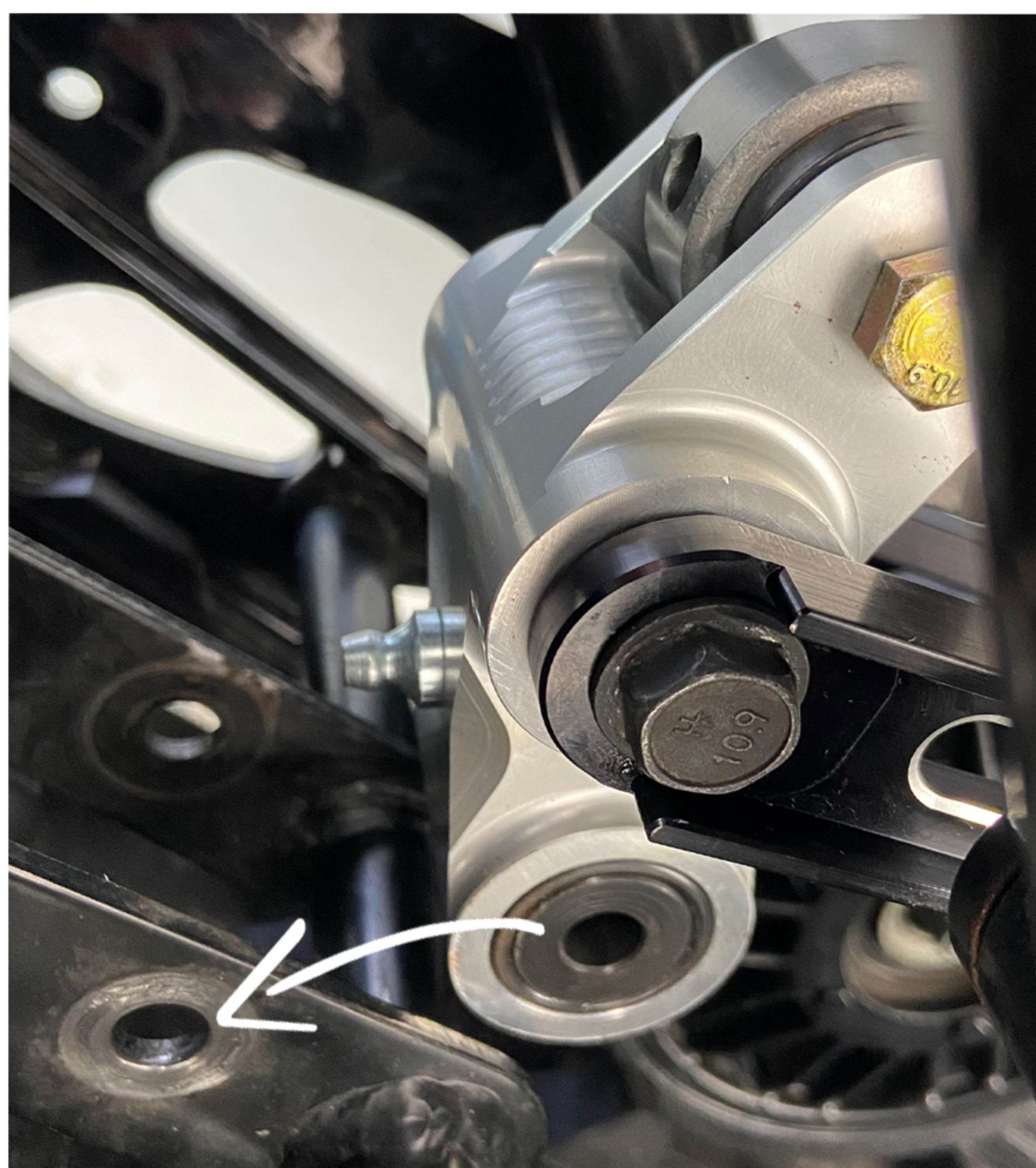

The cam will need to be levered into position in order to install the lower mounting bolt.



Note* Added protection is recommended when levering the cam into position to prevent cosmetic damage.

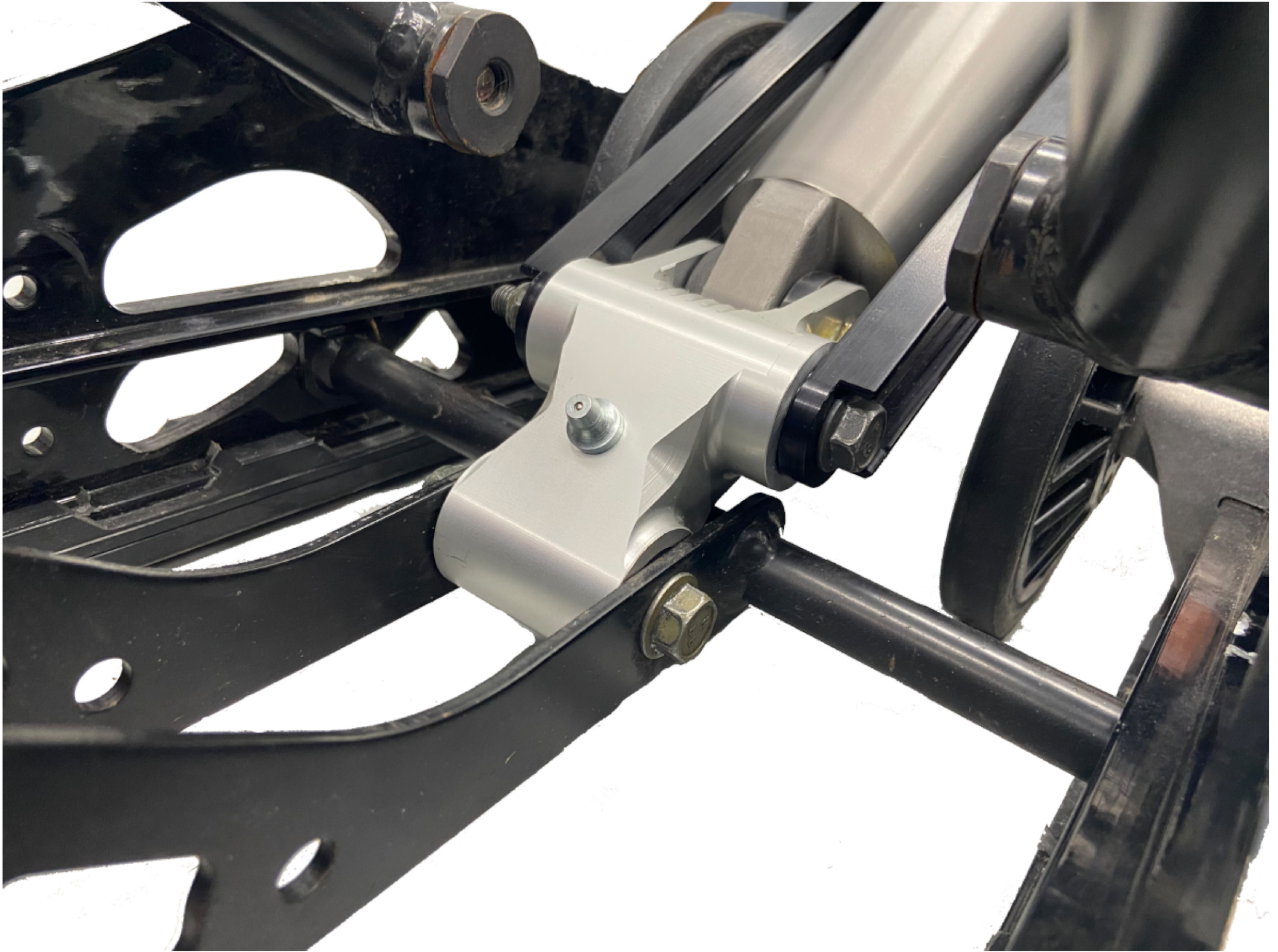

When installing the linkage system with the suspension removed from your vehicle. You may find the shock position overcame from std orientation. This is due to the factory length shock. This will be corrected once the front and rear arms are mounted into chassis. To assist with the install, you can either remove the lower cam bolt. (Ref. Page#5) Or you can install a .625" id x .75" tlg spacer inside the shock. (PN#71-35-004-A Sold Separately) This is not required but helps with instances of frequent shock removal and installation.



308 Peruville Rd. Freevile, NY 13068

If in doubt, just ask!

info@hygearsuspension.com

Page 6 of 6