

SERVING THE FOOD INDUSTRY SINCE 1951

## SOLID DOOR BOTTLE KEG COOLERS WITH BEER DISPENSERS

Item: 50066 (Model: BD-CN-0007-HC)

Item: 50067 (Model: BD-CN-0019-HC)

Item: 50068 (Model: BD-CN-0023-HC)

Item: 50063 (Model: BB-CN-0012-DH)

Item: 50064 (Model: BB-CN-0016-DH)

Item: 50065 (Model: BB-CN-0020-DH)

Item: 50069 (Model: BD-CN-0032-HC)



Designed with enduring quality and value. The exterior comprises of attractive corrosion resistant vinyl on steel in black finish. Durable stainless steel top, interior walls, floor and ceiling. Self-closing doors with locks. It comes with LED lights.



Authorized Dealer



**WARRANTY**

1 YEAR PARTS AND LABOR  
5 YEARS PARTS ON COMPRESSOR



Intertek

Intertek

# REFRIGERATION

BEER DISPENSERS WITH SINGLE DOOR AND 1 SPOUT

# NELLA

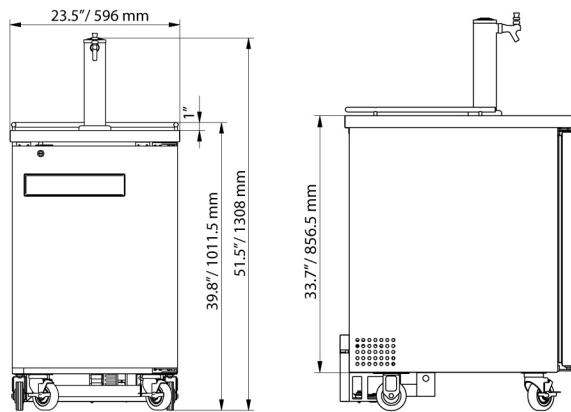

## Features:

- Durable stainless steel top, interior walls, floor and ceiling
- Exterior construction is attractive corrosion resistant vinyl on steel in black finish
- Refrigeration system keeps the drinks at safe temperatures between 33°F and 41°F (0.5°C to 5°C)
- Shelves: Adjustable heavy-duty PVC coated shelves
- Self-Closing doors with locks
- LED interior lighting
- Removable installation board makes it easy to access condenser coil for cleaning and service
- Refrigerant: HYDRO-CARBON R290



Stainless steel top tray cover



Optional order (Item 44224):  
Double tap tower



Thermometer

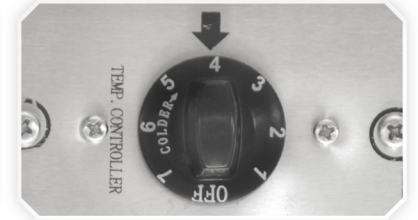

Mechanical temperature controller

## TECHNICAL SPECIFICATION

ITEM NUMBER	50066	COMPRESSOR HP	1/6
MODEL	BD-CN-0007-HC	ELECTRICAL	115V / 60Hz / 1Ph
POWER	1/6 HP	AMPS	1.92A
PRODUCT CAPACITY	One 1/2 barrel	OVERALL DIMENSIONS (DWH)	30.8" x 23.5" x 51.5" / 782 x 596 x 1308 mm
NUMBER OF DOORS	1	INTERIOR DIMENSIONS	19.5" x 25.8" x 28.6" / 496 x 655 x 726 mm
TEMPERATURE RANGE	0.5 - 5 °C / 33 - 41 °F	PACKAGING DIMENSIONS	25.2" x 32" x 48" / 640 x 815 x 1220 mm
CAPACITY	6.5 cu. ft.	WEIGHT	70 kg/ 154 lbs
NUMBER OF SHELVES	N/A	PACKAGING WEIGHT	80 kg/ 176 lbs

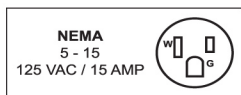

# NELLA

Telephone: 416-740-2424  
Email: [help@nellaonline.com](mailto:help@nellaonline.com)  
Website: [www.nellaonline.com](http://www.nellaonline.com)

# REFRIGERATION

## BEER DISPENSERS WITH DOUBLE DOOR AND 1 SPOUT

# NELLA

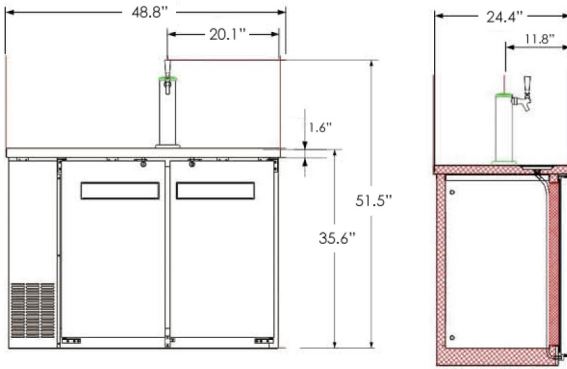

### Features:

- Durable stainless steel top, interior walls, floor and ceiling
- Exterior construction is attractive corrosion resistant vinyl on steel in black finish
- Refrigeration system keeps the drinks at safe temperatures between 33°F and 41°F (0.5°C to 5°C)
- Shelves: Adjustable heavy-duty PVC coated shelves
- Self-Closing doors with locks
- LED interior lighting
- Removable installation board makes it easy to access condenser coil for cleaning and service
- Refrigerant: HYDRO-CARBON R290



Stainless steel top tray cover



Optional order (Item 44224):  
Double tap tower



Shelf

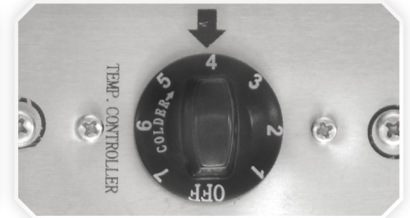

Mechanical temperature controller

### TECHNICAL SPECIFICATION

ITEM NUMBER	50063	COMPRESSOR HP	1/5 HP
MODEL	BB-CN-0012-DH	ELECTRICAL	115V / 60Hz / 1Ph
POWER	150 kW	AMPS	3
PRODUCT CAPACITY	Two 1/2 barrels	OVERALL DIMENSIONS (DWH)	48.8" x 24.4" x 35.6" / 1240 x 620 x 905 mm
NUMBER OF DOORS	2	INTERIOR DIMENSIONS	36 1/4" x 18 1/2" x 30 1/2" / 920 x 470 x 775 mm
TEMPERATURE RANGE	0.5 - 5 °C / 33 - 41 °F	PACKAGING DIMENSIONS	51 1/8" x 27 4/8" x 42 3/8" / 1300 x 700 x 1075 mm
CAPACITY	11.8 cu. ft.	WEIGHT	98 kg. / 216 lbs.
NUMBER OF SHELVES	4	PACKAGING WEIGHT	118 kg. / 260 lbs.

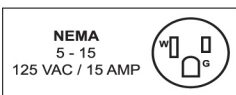

# NELLA

Telephone: 416-740-2424  
Email: [help@nellaonline.com](mailto:help@nellaonline.com)  
Website: [www.nellaonline.com](http://www.nellaonline.com)

# REFRIGERATION

BEER DISPENSERS WITH DOUBLE DOOR  
AND 1 SPOUT

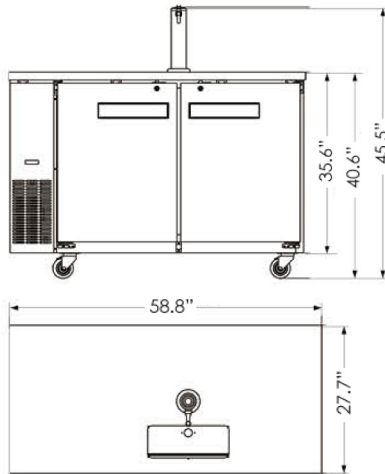

## Features:

- Durable stainless steel top, interior walls, floor and ceiling
- Exterior construction is attractive corrosion resistant vinyl on steel in black finish
- Refrigeration system keeps the drinks at safe temperatures between 33°F and 41°F (0.5°C to 5°C)
- Shelves: Adjustable heavy-duty PVC coated shelves
- Self-Closing doors with locks
- LED interior lighting
- Removable installation board makes it easy to access condenser coil for cleaning and service
- Refrigerant: HYDRO-CARBON R290



Stainless steel top tray cover



Optional order (Item 44224):  
Double tap tower



Shelf

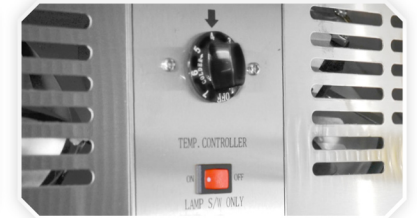

Mechanical temperature  
controller

## TECHNICAL SPECIFICATION

ITEM NUMBER	50067	COMPRESSOR HP	1/5
MODEL	BD-CN-0019-HC	ELECTRICAL	110V / 60Hz / 1Ph
POWER	150 kW	AMPS	2.88
PRODUCT CAPACITY	Two 1/2 barrels	OVERALL DIMENSIONS (DWH)	58.8" x 27.7" x 35.6" / 1495 x 705 x 905 mm
NUMBER OF DOORS	2	INTERIOR DIMENSIONS	46" x 21.8" x 28.9" / 1170 x 555 x 735 mm
TEMPERATURE RANGE	0.5 - 5 °C / 33 - 41 °F	PACKAGING DIMENSIONS	61 28" x 30 4/8" x 41 6/8" / 1555 x 775 x 1060 mm
CAPACITY	19 cu. ft.	WEIGHT	127 kg. / 279 lbs.
NUMBER OF SHELVES	4	PACKAGING WEIGHT	142 kg. / 312 lbs.

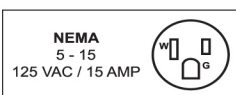

# NELLA

Telephone: 416-740-2424  
Email: [help@nellaonline.com](mailto:help@nellaonline.com)  
Website: [www.nellaonline.com](http://www.nellaonline.com)

# REFRIGERATION

## BEER DISPENSERS WITH DOUBLE DOOR AND 2 SPOUTS

# NELLA

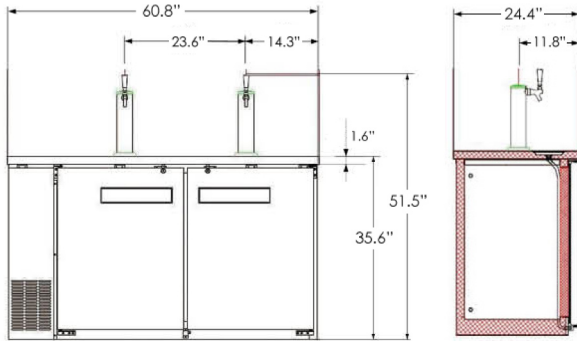

### Features:

- Durable stainless steel top, interior walls, floor and ceiling
- Exterior construction is attractive corrosion resistant vinyl on steel in black finish
- Refrigeration system keeps the drinks at safe temperatures between 33°F and 41°F (0.5°C to 5°C)
- Shelves: Adjustable heavy-duty PVC coated shelves
- Self-Closing doors with locks
- LED interior lighting
- Removable installation board makes it easy to access condenser coil for cleaning and service
- Refrigerant: HYDRO-CARBON R290



Stainless steel top tray cover



Optional order (Item 44224):  
Double tap tower



Shelf

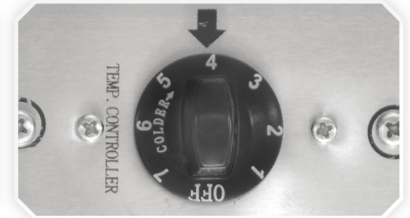

Mechanical temperature controller

### TECHNICAL SPECIFICATION

ITEM NUMBER	50064	COMPRESSOR HP	1/5 HP
MODEL	BB-CN-0016-DH	ELECTRICAL	115V / 60Hz / 1Ph
POWER	150 kW	AMPS	3
PRODUCT CAPACITY	Two 1/2 barrels	OVERALL DIMENSIONS (DWH)	60.8" x 24.4" x 35.6" / 1544 x 620 x 905 mm
NUMBER OF DOORS	2	INTERIOR DIMENSIONS	48 1/4" x 18 1/2" x 30 1/2" / 1224 x 470 x 775 mm
TEMPERATURE RANGE	0.5 - 5 °C / 33 - 41 °F	PACKAGING DIMENSIONS	63 3/8" x 27 4/8" x 42 3/8" / 1610 x 700 x 1075 mm
CAPACITY	15.8 cu. ft.	WEIGHT	116 kg. / 255 lbs.
NUMBER OF SHELVES	4	PACKAGING WEIGHT	145 kg. / 319 lbs.

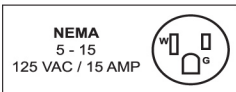

# NELLA

Telephone: 416-740-2424  
Email: [help@nellaonline.com](mailto:help@nellaonline.com)  
Website: [www.nellaonline.com](http://www.nellaonline.com)

# REFRIGERATION

BEER DISPENSERS WITH DOUBLE DOOR  
AND 2 SPOUTS

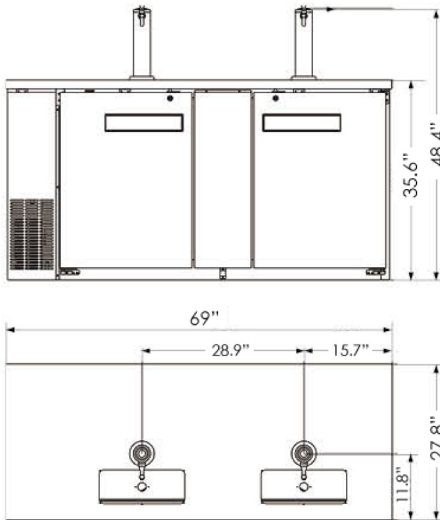

## Features:

- Durable stainless steel top, interior walls, floor and ceiling
- Exterior construction is attractive corrosion resistant vinyl on steel in black finish
- Refrigeration system keeps the drinks at safe temperatures between 33°F and 41°F (0.5°C to 5°C)
- Shelves: Adjustable heavy-duty PVC coated shelves
- Self-Closing doors with locks
- LED interior lighting
- Removable installation board makes it easy to access condenser coil for cleaning and service
- Refrigerant: HYDRO-CARBON R290



Stainless steel top tray cover



Optional order (Item 44224):  
Double tap tower



Shelf

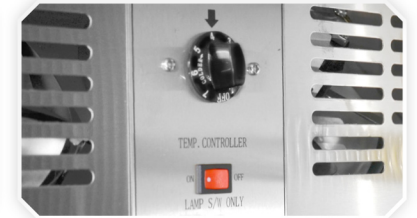

Mechanical temperature controller

## TECHNICAL SPECIFICATION

ITEM NUMBER	50068	COMPRESSOR HP	1/5
MODEL	BD-CN-0023-HC	ELECTRICAL	110V / 60Hz / 1Ph
POWER	150 kW	AMPS	3.6
PRODUCT CAPACITY	Three 1/2 barrels	OVERALL DIMENSIONS (DWH)	69.1" x 27.8" x 35.6" / 1755 x 705 x 905 mm
NUMBER OF DOORS	2	INTERIOR DIMENSIONS	56.3" x 21.8" x 29" / 1430 x 555 x 735 mm
TEMPERATURE RANGE	0.5 - 5 °C / 33 - 41 °F	PACKAGING DIMENSIONS	71 4/8" x 30 4/8" x 41 6/8" / 1815 x 775 x 1060 mm
CAPACITY	23.3 cu. ft.	WEIGHT	148 kg. / 326 lbs.
NUMBER OF SHELVES	4	PACKAGING WEIGHT	167 kg. / 367 lbs.

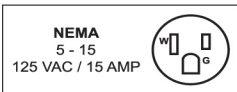

Telephone: 416-740-2424  
Email: [help@nellaonline.com](mailto:help@nellaonline.com)  
Website: [www.nellaonline.com](http://www.nellaonline.com)

# REFRIGERATION

## BEER DISPENSERS WITH TRIPLE DOOR AND 2 SPOUTS

# NELLA

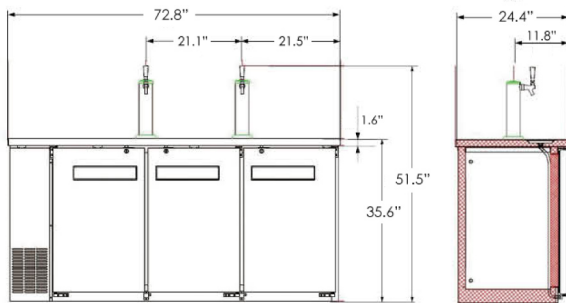

### Features:

- Durable stainless steel top, interior walls, floor and ceiling
- Exterior construction is attractive corrosion resistant vinyl on steel in black finish
- Refrigeration system keeps the drinks at safe temperatures between 33°F and 41°F (0.5°C to 5°C)
- Shelves: Adjustable heavy-duty PVC coated shelves
- Self-Closing doors with locks
- LED interior lighting
- Removable installation board makes it easy to access condenser coil for cleaning and service
- Refrigerant: HYDRO-CARBON R290

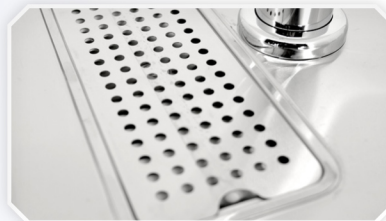

Stainless steel top tray cover



Optional order (Item 44224):  
Double tap tower



Shelf

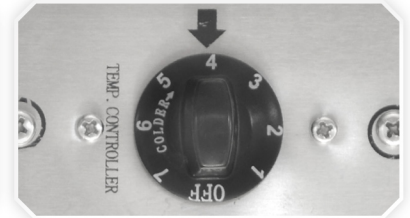

Mechanical temperature controller

### TECHNICAL SPECIFICATION

ITEM NUMBER	50065	COMPRESSOR HP	1/4+
MODEL	BB-CN-0020-DH	ELECTRICAL	115V / 60Hz / 1Ph
POWER	196 kW	AMPS	4
PRODUCT CAPACITY	Three 1/2 barrels	OVERALL DIMENSIONS (WDH)	72.8" x 24.4" x 35.6" / 1848 x 620 x 905 mm
NUMBER OF DOORS	3	INTERIOR DIMENSIONS	60 1/8" x 18 1/2" x 30 1/2" / 1528 x 470 x 775 mm
TEMPERATURE RANGE	0.5 - 5 °C / 33 - 41 °F	PACKAGING DIMENSIONS	75 2/8" x 27 4/8" x 42 3/8" / 1910 x 700 x 1075 mm
CAPACITY	19.6 cu. ft.	WEIGHT	141 kg. / 310 lbs.
NUMBER OF SHELVES	6	PACKAGING WEIGHT	175 kg. / 385 lbs.

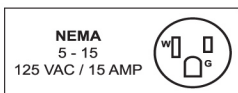

# NELLA

Telephone: 416-740-2424  
Email: [help@nellaonline.com](mailto:help@nellaonline.com)  
Website: [www.nellaonline.com](http://www.nellaonline.com)

# REFRIGERATION

BEER DISPENSERS WITH TRIPLE DOOR  
AND 2 SPOUTS

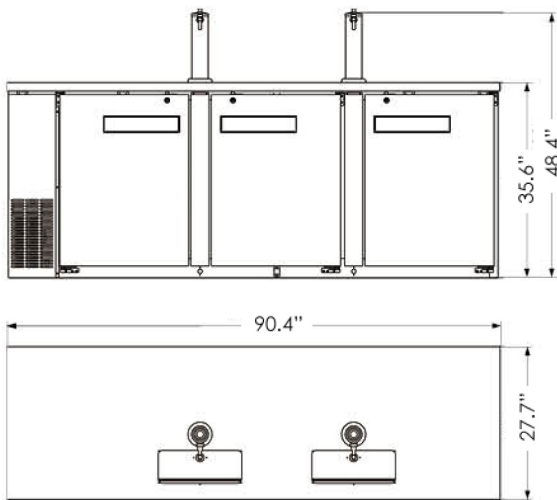

### Features:

- Durable stainless steel top, interior walls, floor and ceiling
- Exterior construction is attractive corrosion resistant vinyl on steel in black finish
- Refrigeration system keeps the drinks at safe temperatures between 33°F and 41°F (0.5°C to 5°C)
- Shelves: Adjustable heavy-duty PVC coated shelves
- Self-Closing doors with locks
- LED interior lighting
- Removable installation board makes it easy to access condenser coil for cleaning and service
- Refrigerant: HYDRO-CARBON R290



Stainless steel top tray cover



Optional order (Item 44224):  
Double tap tower



Shelf



Mechanical temperature controller

### TECHNICAL SPECIFICATION

ITEM NUMBER	50069	COMPRESSOR HP	1/4+
MODEL	BD-CN-0032-HC	ELECTRICAL	110V / 60Hz / 1Ph
POWER	196 kW	AMPS	4.7
PRODUCT CAPACITY	Four 1/2 barrels	OVERALL DIMENSIONS (WDH)	90.4" x 27.7" x 35.6" / 2295 x 705 x 905 mm
NUMBER OF DOORS	3	INTERIOR DIMENSIONS	77.5" x 21.8" x 29" / 1970 x 555 x 735 mm
TEMPERATURE RANGE	0.5 - 5 °C / 33 - 41 °F	PACKAGING DIMENSIONS	91 6/8" x 30 4/8" x 41 6/8" / 2330 x 775 x 1060 mm
CAPACITY	32 cu. ft.	WEIGHT	170 kg. / 374 lbs.
NUMBER OF SHELVES	6	PACKAGING WEIGHT	195 kg. / 429 lbs.

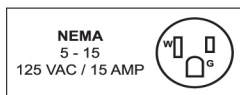

Telephone: 416-740-2424  
Email: [help@nellaonline.com](mailto:help@nellaonline.com)  
Website: [www.nellaonline.com](http://www.nellaonline.com)