

HOTDOG & SNEEZE GUARDS (OPTIONAL)

Item: 44131
Model: FW-CN-0005-E

Item: 44132
Model: FW-CN-0007-E

Item: 44133
Model: FW-CN-0009-E

Item: 44152
(Sneeze guard for 44131)

Item: 44153
(Sneeze guard for 44132)

Item: 44154
(Sneeze guard for 44133)

FEATURES

- Made of stainless steel
- Individual temperature control knobs (0-250°C) for front and back
- Removable drip tray for excessive oil and food
- Non-skid rubber feet prevent sliding
- Easy to use and clean
- Perfect for movie theater, snack bar, farmer market, sport events, concessions stand and even your kitchen



WARRANTY
PARTS AND LABOR



Authorized Dealer



COOKING EQUIPMENT

HOTDOG ROLLER - 5 ROLLERS

NELLA



Rear side

TECHNICAL
DRAWING WITH
DIMENSIONS

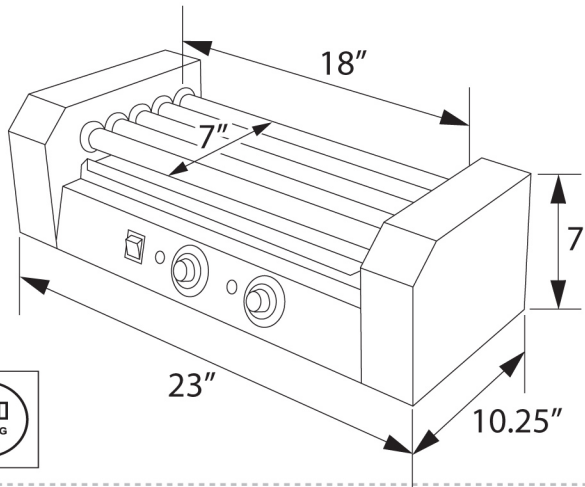

NEMA
5 - 15
125 VAC / 15 AMP



Individual temperature controls



5 Stainless steel rollers

TECHNICAL SPECIFICATION

ITEM NUMBER	44131
MODEL	FW-CN-0005-E
NUMBER OF ROLLERS	5
CAPACITY (QTY. OF HOTDOG)	12
LENGTH OF ROLLERS	17" / 431.8 mm
TEMPERATURE (FRONT & BACK)	0 - 250°C / 32 - 482°F
ELECTRICAL	110v/60hz/1ph
POWER	0.7 kW
NET WEIGHT	15 lbs/ 6.8 kg.
GROSS WEIGHT	16.5 lbs./ 7.5 kg.
NET DIMENSIONS	10.25" x 23" x 7" / 260.4 x 584 x 178 mm
GROSS DIMENSIONS	23.6" x 12" x 7" / 600 x 300 x 178 mm
OPTIONAL ITEM	44152 (Sneeze guard)



Optional sneeze guard

NELLA

Telephone: 416-740-2424
Email: help@nellaonline.com
Website: www.nellaonline.com

COOKING EQUIPMENT

HOTDOG ROLLER - 7 ROLLERS

NELLA



Rear side

TECHNICAL
DRAWING WITH
DIMENSIONS

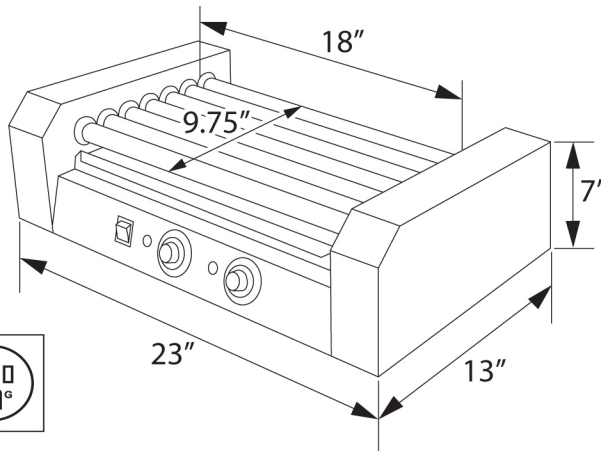

NEMA
5 - 15
125 VAC / 15 AMP



Individual temperature controls



7 Stainless steel rollers



Optional sneeze guard

TECHNICAL SPECIFICATION

ITEM NUMBER	44132
MODEL	FW-CN-0007-E
NUMBER OF ROLLERS	7
CAPACITY (QTY. OF HOTDOG)	18
LENGTH OF ROLLERS	17" / 431.8 mm
TEMPERATURE (FRONT & BACK)	0 - 250°C / 32 - 482°F
ELECTRICAL	110v/60hz/1ph
POWER	0.9 kW
NET WEIGHT	19 lbs. / 8.6 kg.
GROSS WEIGHT	20 lbs. / 9 kg.
NET DIMENSIONS	13" x 23" x 7" / 330 x 584 x 178 mm
GROSS DIMENSIONS	24" x 19" x 7" / 609.6 x 482.6 x 178 mm
OPTIONAL ITEM	44153 (Sneeze guard)

NELLA

Telephone: 416-740-2424
 Email: help@nellaonline.com
 Website: www.nellaonline.com

COOKING EQUIPMENT

HOTDOG ROLLER - 9 ROLLERS

NELLA



Rear side

TECHNICAL
DRAWING WITH
DIMENSIONS

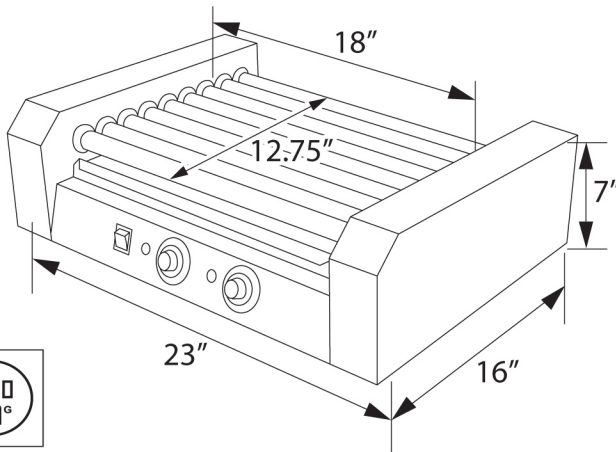

NEMA
5 - 15
125 VAC / 15 AMP



Individual temperature controls



9 Stainless steel rollers

TECHNICAL SPECIFICATION

ITEM NUMBER	44133
MODEL	FW-CN-0009-E
NUMBER OF ROLLERS	9
CAPACITY (QTY. OF HOTDOG)	24
LENGTH OF ROLLERS	17" / 431.8 mm
TEMPERATURE (FRONT & BACK)	0 - 250°C / 32 - 482°F
ELECTRICAL	110v/60hz/1ph
POWER	1.2 kW
NET WEIGHT	24 lbs. / 10.88 kg.
GROSS WEIGHT	25 lbs / 11 kg.
NET DIMENSIONS	16" x 23" x 7" / 406 x 584 x 178 mm
GROSS DIMENSIONS	24" x 19" x 7" / 609.6 x 482.6 x 178 mm
OPTIONAL ITEM	44154 (Sneeze guard)



Optional sneeze guard

NELLA

Telephone: 416-740-2424
Email: help@nellaonline.com
Website: www.nellaonline.com