

SERVING THE FOOD INDUSTRY SINCE 1951

COUNTERTOP SINGLE AND DOUBLE BULB HEAT LAMP

Item #:39602/ 39601

Model: FW-CN-0736/ FW-CN-0936



- Great for fast food restaurants, snack bars, catering, concession stands and buffets
- Perfect for keeping potato wedges, french fries, chicken or onion rings warm and ready to serve
- CE certified



Detail Shots



275 Watt
Infrared Bulbs



Ventilated Reflectors



Comes with a drip tray



One switch per lamp



110-120V
Electrical connector

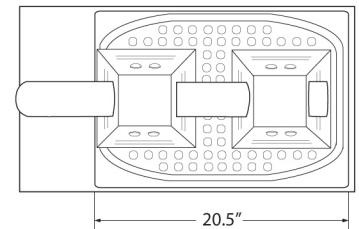
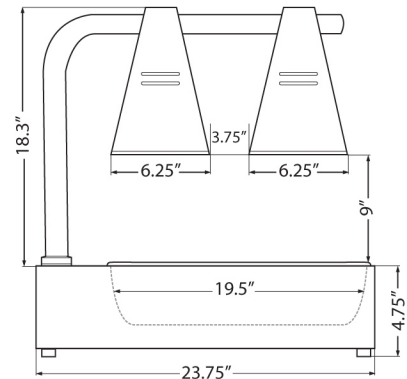
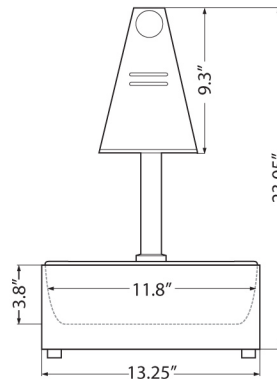
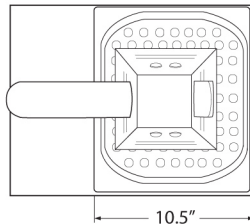
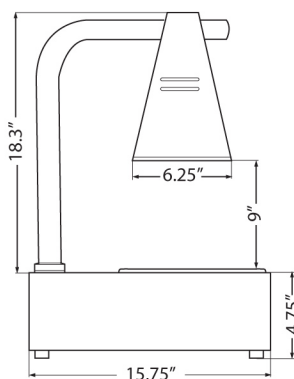
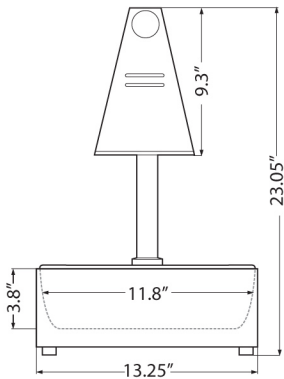

COUNTERTOP SINGLE BULB HEAT LAMP

ITEM NUMBER	39602
MODEL	FW-CN-0736
INPUT POWER	0.275 kW
ELECTRICAL	110V / 60Hz
NET WEIGHT	14 lbs/ 6 kg.
PACKAGING WEIGHT	16 lbs/ 7 kg.
DIMENSIONS (DWH)	15.7" x 13.25" x 23.05" 40 x 33.7 x 58.5 cm
PACKAGING DIMENSIONS	16" x 18" x 25"/ 406 x 457 x 635 mm

COUNTERTOP DOUBLE BULB HEAT LAMP

ITEM NUMBER	39601
MODEL	FW- CN-0936
INPUT POWER	0.275 kW
ELECTRICAL	110V / 60Hz
NET WEIGHT	12 lbs./ 5.4 kg.
PACKAGING WEIGHT	14 lbs./ 6 kg.
DIMENSIONS (DWH)	23.75" x 13.25" x 23.05" 60.3 x 33.7 x 58.5 cm
PACKAGING DIMENSIONS	16" x 26" x 24"/ 406 x 660 x 409.6 mm