

SERVING THE FOOD INDUSTRY SINCE 1951

UTILITY CARTS

Nella's Utility Carts are sturdily constructed to endure tough everyday handling. Finished for easy cleaning. Great for supermarkets and various food service operations. Shipped knock-down.

*Middle shelf is optional.
2 Sizes Available.*



WARRANTY



SHIPPED ON PALLET



Authorized Dealer

HANDLING AND STORAGE

UTILITY CARTS 39247 / 23861



TECHNICAL DRAWING AND DIMENSIONS

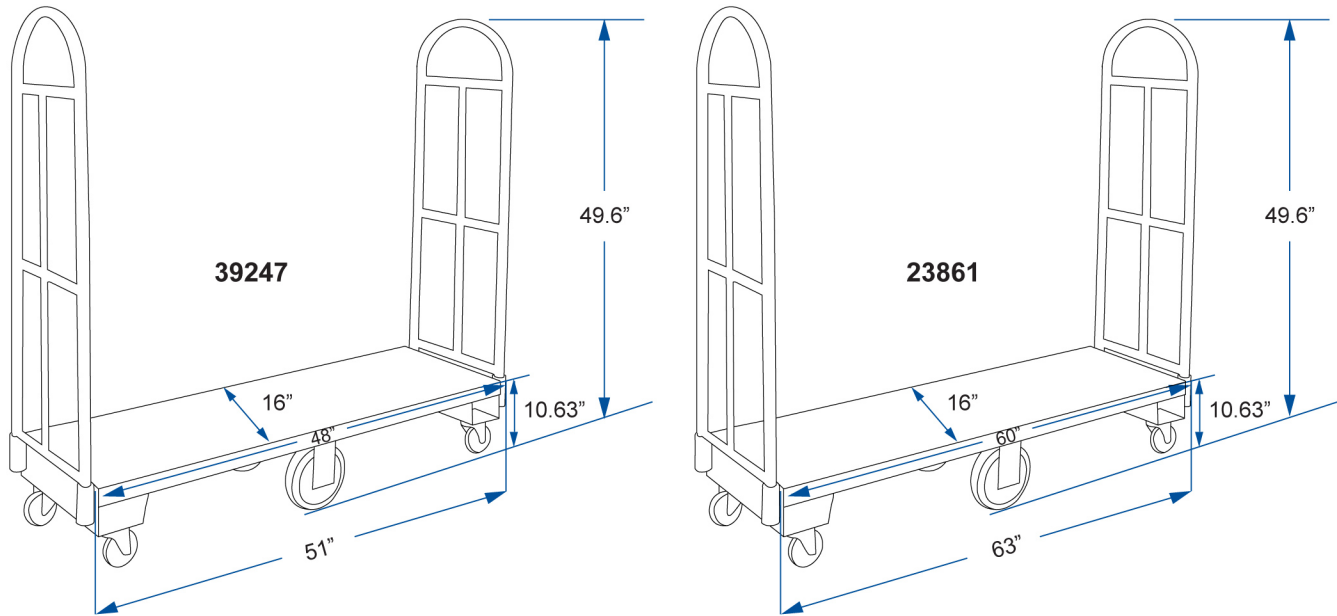

TECHNICAL SPECIFICATIONS

ITEM	39247	23861
DESCRIPTION	Utility Cart Steel 16" x 48"	Utility Cart Steel 16" x 60"
LOAD CAPACITY	2000 lbs. / 907 kg.	2000 lbs. / 907 kg.
WEIGHT	80 lbs. / 36 kg.	92 lbs. / 41 kg.
GROSS WEIGHT	162 lbs. / 73 kg.	186 lbs. / 84 kg.
DIMENSIONS (DWH)	51" x 16" x 49.6" / 1295.4 x 406 x 1260 mm	63" x 16" x 49.6" / 1600 x 406 x 1260 mm
GROSS DIMENSIONS	53" x 17" x 15" / 1346 x 432 x 381 mm	72" x 17" x 15" / 1829 x 432 x 381 mm

OPTIONAL SHELVES

ITEM	39248	13119
DESCRIPTION	Shelf for Item 39247	Shelf for Item 23861
LOAD CAPACITY	154 lbs. / 70 kg.	154 lbs. / 70 kg.
WEIGHT	21 lbs. / 9.5 kg.	27 lbs. / 12 kg.
GROSS WEIGHT	136 lbs. / 62 kg.	176 lbs. / 80 kg.
DIMENSIONS	48" x 16" / 1219 x 406 mm	60" x 16" / 1524 x 406 mm
GROSS DIMENSIONS	48" x 16" x 0.80" / 1219 x 406 x 20 mm	60" x 16" x 0.80" / 1524 x 406 x 20 mm



Telephone: 416-740-2424
 Email: help@nellaonline.com
 Website: www.nellaonline.com