



HEAVY-DUTY ELECTRICAL MEAT MIXER

Item #: 37450/ 37451

Model: MM-IT-0080/ MM-IT-0120



Removable Mixing Arms



Tank Overturn

Item# 37451
Model: MM-IT-0120

Item# 37450
Model: MM-IT-0080



Authorized Dealer



Features:

- Modern design and strong AISI 304 stainless steel construction
- Tilting tank with automatic locking system and safety lock
- Stainless steel swivel wheels with lock
- Two mixing arms system
- Removable AISI 304 stainless steel mixing arms (no tools required)
- Total protection of gear box/control panel
- Oil-bath gear box, ground and tempered helical gears
- Double seal on tank and gear box
- **IP 54 control:** forward and reverse, auto-off feature, auto-function with reverse
- Stainless steel cover with safety microswitch
- Minimum loading required: 40% max capacity
- Stainless steel IP 67 controls
- Perfect for hard mix and salad
- Optional: Speed control with inverter system

PRODUCT SPECIFICATIONS

ITEM	37450
MODEL	MM-IT-0080
POWER	550 W / 0.75 HP (x2)
ELECTRICAL	220 V / 60 / 1
TANK DIMENSIONS	24" x 20" / 62cm x 50cm
CAPACITY	110 L / 80 kg.
DIMENSIONS (DWH)	25" x 39" x 41" / 63.5cm x 99cm x 104cm
WEIGHT	198 lbs. / 90 kg.
GROSS DIMENSIONS	47" x 26" x 51" / 119cm x 66cm x 129.5cm
GROSS WEIGHT	242.5 lbs. / 110 kg.

110 L ELECTRICAL MEAT MIXER

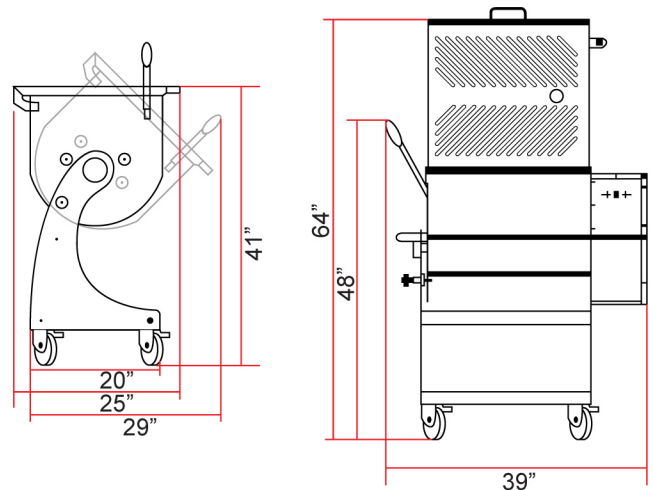

PRODUCT SPECIFICATIONS

ITEM	37451
MODEL	MM-IT-0120
POWER	735 W / 1 HP (x2)
ELECTRICAL	220 V / 60 / 3
TANK DIMENSIONS	26" x 21.7" / 66cm x 55cm
CAPACITY	163 L / 120 kg.
DIMENSIONS (DWH)	27.6" x 43" x 40.5" / 70cm x 109cm x 103cm
WEIGHT	304.2 lbs. / 138 kg.
GROSS DIMENSIONS	29.5" x 57" x 51.2" / 75cm x 145cm x 130cm
GROSS WEIGHT	368.2 lbs. / 167 kg.

163 L ELECTRICAL MEAT MIXER

