

SERVING THE FOOD INDUSTRY SINCE 1951

## MANUAL / TILTING MEAT MIXERS

**PERFECT SOLUTION FOR SEASONING  
GROUND MEAT AND SAUSAGES**



Designed to thoroughly and consistently season ground meat from small to medium batches for simple sausage making. Constructed of stainless steel, these mixers are equipped with a removable paddle and a clear plastic cover for easy cleaning.



LIMITED  
**WARRANTY**



Authorized Dealer



**TECHNICAL SPECIFICATION**

ITEM NUMBER	19202
WORKING CAPACITY	17 lbs. / 7.7 kg.
WEIGHT	15 lbs. / 6.8 kg.
PACKAGING WEIGHT	20 lbs. / 9 kg.
DIMENSIONS	22" x 10" x 15.5" 558 x 254 x 394 mm
PACKAGING DIMENSIONS	19.5" x 16" x 13" 495 x 406 x 330 mm

**TECHNICAL DRAWING AND DIMENSIONS**

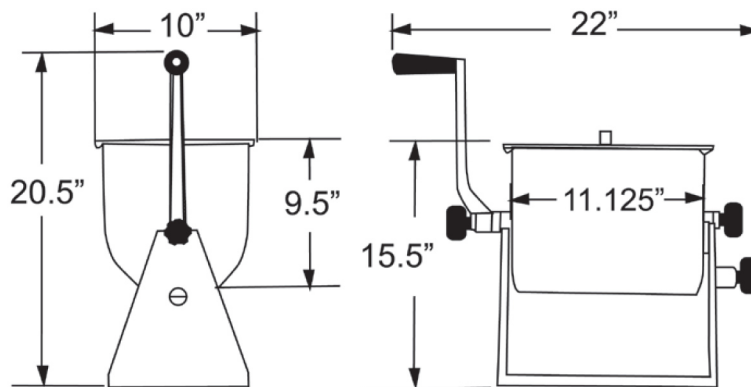

**Features**

- Mixes up to 17 lbs. / 7.7 kg.
- 4.2 gallon tank capacity
- Bowl of the mixer tilts to make addition and removal of meat fast and efficient
- Removable paddle for quick and easy clean up
- Manual operation





### TECHNICAL SPECIFICATION

ITEM NUMBER	19203
WORKING CAPACITY	44 lbs. / 20 kg.
WEIGHT	25 lbs. / 11.3 kg.
PACKAGING WEIGHT	30 lbs. / 13.6 kg.
DIMENSIONS	24" x 12.75" x 18.25" 610 x 324 x 464 mm
PACKAGING DIMENSIONS	20.25" x 20" x 15.5" 514 x 508 x 394 mm

### Features

- Mixes up to 44 lbs. / 20 kg.
- 7 gallon tank capacity
- Bowl of the mixer tilts to make addition and removal of meat fast and efficient
- Removable paddle for quick and easy clean up
- Manual operation

### TECHNICAL DRAWING AND DIMENSIONS

