

NELLA

KITCHEN EQUIPMENT

SERVING THE FOOD INDUSTRY SINCE 1951

14-INCH BLADE SLICER

Item: 23544 Model: MS-CN-0350



**EASILY AND EFFICIENTLY
CUT MEATS AND VEGETABLES**

Perfect for low volume operations

Nella's 14-inch blade slicer have anodised aluminum alloy body. Boasting a 0.50 horsepower, it offers exceptional cutting consistency and durability. Easy to disassemble for quick cleaning.



WARRANTY
PARTS AND LABOR

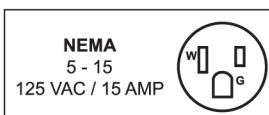

Authorized Dealer

TECHNICAL DRAWINGS AND DIMENSIONS

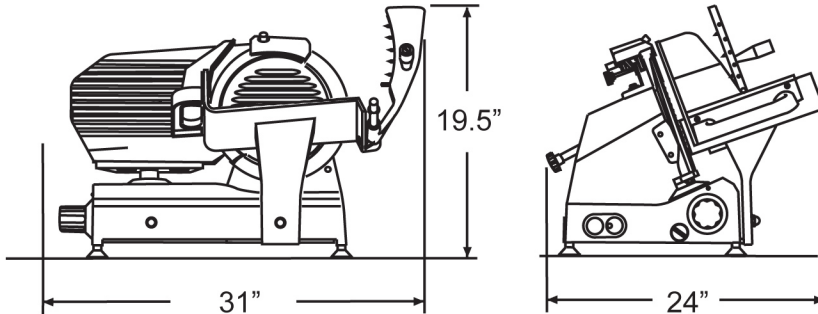

TECHNICAL SPECIFICATIONS

ITEM NUMBER	23544
MODEL	MS-CN-0350
BLADE SIZE	14" / 350 mm
CUT THICKNESS	0.2 - 15 mm
CUTTING SIZE	12.59" x 14" / 319.7 x 355.6 mm
POWER	0.50 HP / 0.37 kW
CHEESE SLICING*	
SLICING VOLUME*	1 hour
RPM	240
ELECTRICAL	110V / 60Hz / 1Ph
WEIGHT	130 lbs. / 59 kg.
GROSS WEIGHT	133 lbs. / 60.45 kg.
DIMENSIONS (WDH)	31" x 24" x 19.50" / 787.4 x 609.6 x 495.3 mm
GROSS DIMENSIONS	32" x 27" x 23" / 812.8 x 685.8 x 584.2 mm

*CHEESE SLICING RATINGS NOT RECOMMENDED → POOR → AVERAGE → GOOD → EXCELLENT →

*Results may vary due to product consistency and temperature.

FEATURES

- Anodised aluminium alloy body
- High carbon steel blades are hard chromed, with a hollow ground taper for extended sharpening and blade life
- Offers exceptional cutting consistency and durability
- Carriage moves smoothly on ball bearings allowing effortless cutting of deli meats and vegetables
- Easy to disassemble for quick cleaning
- Perfect for low volume operations

PRODUCT DETAILS

