



MATURMEAT®

USER AND MAINTENANCE MANUAL

INDEX

MATURMEAT™

- Pag. 3 1.1 General Safety Warnings
- Pag. 4 1.2 Identification Data & Data Plate
- Pag. 4 1.3 Standard Accessories
- Pag. 5 1.4 Maturmeat™ Diagram
- Pag. 6 1.5 Receipt Inspection
- Pag. 6 1.6 Installation

CLIMATOUCH®

- Pag. 8 2.1 Using Climatouch® For The First Time
- Pag. 9 2.2 Starting The Test Recipe
- Pag. 10 2.3 Recipe Screen Defined
- Pag. 12 2.4 Starting a Default Climatic Recipe
- Pag. 12 2.5 Modifying Recipe Parameters
- Pag. 13 2.6 Checking HACCP-Performance as Line Data
- Pag. 14 2.7 Checking HACCP-Performance as a Graph
- Pag. 15 2.8 New Recipe Parameters Defined
- Pag. 16 2.9 Creating and Saving New Recipes
- Pag. 19 2.10 Starting a Saved Recipe
- Pag. 19 2.11 Forcing Aroma

MAINTANENCE

- Pag. 20 3.1 Calibrating Standard Probes
- Pag. 21 3.2 Calibrating pH Probe
- Pag. 23 3.3 Fumotic's supply tanks
- Pag. 23 3.4 Water Filter
- Pag. 24 3.5 Fumotic® Rear View
- Pag. 24 3.6 Fumotic® Front View
- Pag. 25 3.7 How to connect direct waterline to Fumotic®
- Pag. 25 3.8 How to remove calcium from Fumotic®
- Pag. 26 3.9 Cleaning Maturmeat™
- Pag. 27 3.10 Changing the Light
- Pag. 27 3.11 Emptying drain tray
- Pag. 28 3.12 Temperature Maintenance
- Pag. 29 3.13 Humidity Maintenance
- Pag. 30 3.14 Firmware Update Climatouch®
- Pag. 32 3.15 Firmware Update PLC's
- Pag. 34 3.16 Troubleshooting

TECHNICAL INFORMATION & DATA

- Pag. 36 4.1 System Variables
- Pag. 42 4.2 Maturmeat™ Specifications
- Pag. 42 4.3 Climatouch® Specifications
- Pag. 43 4.4 Functions Managed By Climatouch®
- Pag. 44 4.5 PLC A Specifications
- Pag. 45 4.6 PLC B Specifications
- Pag. 46 4.7 Electrical Schematic 100kg
- Pag. 47 4.8 Electrical Schematic 150kg
- Pag. 48 4.9 Electrical Schematic 200kg
- Pag. 49 4.10 Electrical Schematic Twin 100+100kg Table 1
- Pag. 50 4.11 Electrical Schematic Twin 100+100kg Table 2
- Pag. 51 4.12 Electrical Schematic Fumotic® 60/100/150/200kg
- Pag. 52 4.13 Electrical Schematic Fumotic® Twin 100+100kg

WARRANTY & DISPOSAL

- Pag. 53 5.1 Limited Warranty
- Pag. 54 5.2 Proper Disposal

Your safety and the safety of others are very important.

We have provided many important safety messages in this manual and on your appliance. Always read and obey all safety messages.



This is the safety alert symbol.

This symbol alerts you to potential hazards that can kill or hurt you and others.

All safety messages will follow the safety alert symbol and the word "Danger." This word means:

**DANGER**

You can be killed or seriously injured if you don't follow instructions.

All safety messages will tell you what the potential hazard is, tell you how to reduce the chance of injury, and tell you what can happen if the instructions are not followed.

IMPORTANT SAFETY INSTRUCTIONS

WARNING: To reduce the risk of fire, electric shock, or injury when using your Maturmeat™, follow these basic precautions:

- After unpacking, make sure the machine is complete and free from damage. If in doubt, do not use and contact a qualified technician.
- Check that the information on data plate corresponds with the main power supply.
- This appliance must be used exclusively for the purpose for which it was made. Any other use is considered improper and therefore dangerous.
- The machine must be handled only by trained personnel.
- For any eventual repairs please contact an authorized dealer and/or technician, use only original replacement parts.
- Do not wash the machine with high pressure water jets.
- Fumotic® flavoring/humidification processes and humidity probes are not to be used below -3°C (minus three degrees centigrade), and are excluded from operation and consequently unusable and unreliable, the manufacture is not liable for programming differing from the aforementioned
- All working parameters described in brochures, price lists, refer to programming and/or functionality to achieve a single process separately, and not connected or linked.
- Arredo Inox Srl assumes no responsibility for any errors that may appear in this document. In no event shall Arredo Inox Srl be liable for incidental or consequential damages arising from use of this document or the software and hardware described in this document.
- The information contained within the user manual is subject to change without notice and should not be construed as a commitment by Arredo Inox Srl.
- The default climatic recipes programmed in your Maturmeat™ are suggested and are modifiable by the user, they are meant to be used a guide.
- Always shut down power to the unit before attempting any work on the unit, other than the exclusive purpose for which it was made.
- Not respecting any of the aforementioned points may compromise the safety of the machine and or the user.

SAVE THESE INSTRUCTIONS

This manual replaces all previous versions, and contains up to date information on procedures and settings, with the exception of electrical drawings (find production dates on each drawing)

This document and parts thereof must not be reproduced or copied without Arredo Inox Srl's written permission, and contents thereof must not be imparted to a third party nor be used for any unauthorized purpose. Contravention will be prosecuted.

The serial tag is a permanently affixed sticker on which is recorded vital electrical and refrigeration data about your Maturmeat™ product, as well as the model and serial number. There are two data plates on each unit, they can be found on the inside top corner of the doorframe and on the top corner on the right hand side of the body. When contacting the manufacturer, please provide the serial number and production lot number found on your cabinet or on the conformance certificate.

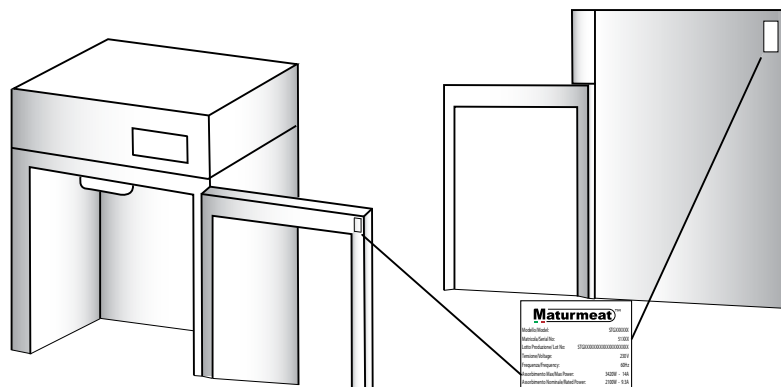

Maturmeat™

Modello/Model: STGXXXXXX
 Matricola/Serial No: 51XXX
 Lotto Produzione/ Lot No: STGXXXXXXXXXXXXXXXXXXXX
 Tensione/Voltage: 230 V
 Frequenza/Frequency: 60Hz
 Assorbimento Max/Max Power: 3420W - 14A
 Assorbimento Nominale/Rated Power: 2100W - 9.3A
 Illuminazione/Lighting: 30W - 0.3A
 Riscaldamento/Heaters: 1500W - 6.2A
 Ricambio Aria/Air Recycling: 40W - 0.5A
 Raffreddamento/Cooling: 670W - 4A
 Umidificazione/Humidification: 1250W - 6A
 Deumidificazione/Dehumidification: 2100W - 9.4A
 Aromatizzazione/Aromatization: 1250W - 6A
 Sbrinatorio/Defrost: 770W - 4A
 Gas Refrigerante/Refrigerant Type: R 404 A
 Quantità Refrigerante/Refrigerant Quantity: 400g
 Classe Climatica/Ambient Temperature: ST
 Max Corr. Operativa (MRA)/Max Operating Curr. (MRA): 2.8A
 Compressore (RLA)/Compressor (RLA): 16.5A

- 1) Brand
- 2) Model
- 3) Serial number
- 4) Production lot number
- 5) Voltage
- 6) Frequency
- 7) Max Power
- 8) Nominal Power
- 9) Power usage for lighting
- 10) Power usage during heating
- 11) Power usage during air cycling
- 12) Power usage during cooling
- 13) Power usage during humidification
- 14) Power usage during dehumidification
- 15) Power usage during flavouring
- 16) Power usage during defrosting
- 17) Refrigerant type
- 18) Refrigerant quantity
- 19) Climatic class
- 20) Max operating current
- 21) Compressor Rated load Amps
- 22) Manufacturer
- 23) Certification
- 24) Country of Origin

Maturmeat	
Modello/Model:	STGXXXXXX
Matricola/Serial No:	51XXX
Lotto Produzione/ Lot No:	STGXXXXXXXXXXXXXXXXXXXX
Tensione/Voltage:	230 V
Frequenza/Frequency:	60Hz
Assorbimento Max/Max Power:	3420W - 14A
Assorbimento Nominale/Rated Power:	2100W - 9.3A
Illuminazione/Lighting:	30W - 0.3A
Riscaldamento/Heaters:	1500W - 6.2A
Ricambio Aria/Air Recycling:	40W - 0.5A
Raffreddamento/Cooling:	670W - 4A
Umidificazione/Humidification:	1250W - 6A
Deumidificazione/Dehumidification:	2100W - 9.4A
Aromatizzazione/Aromatization:	1250W - 6A
Sbrinatorio/Defrost:	770W - 4A
Gas Refrigerante/Refrigerant Type:	R 404 A
Quantità Refrigerante/Refrigerant Quantity:	400g
Classe Climatica/Ambient Temperature:	ST
Max Corr. Operativa (MRA)/Max Operating Curr. (MRA):	2.8A
Compressore (RLA)/Compressor (RLA):	16.5A



CE MADE IN ITALY

STANDARD ACCESSORIES

1.3

The following items are included with your Maturmeat™. Contact your dealer should any of the following be missing

- No. 3 temperature probes;
- No. 1 humidity probe;
- No. 1 closed loop connector (for direct waterline see page 25);
- No. 1 user manual;
- No. 1 warranty registration card;
- No. 1 drain tray;
- No. 1 drain hose;
- No. 5 guide sets (L&R);
- No. 5 stainless steel shelves

1.4

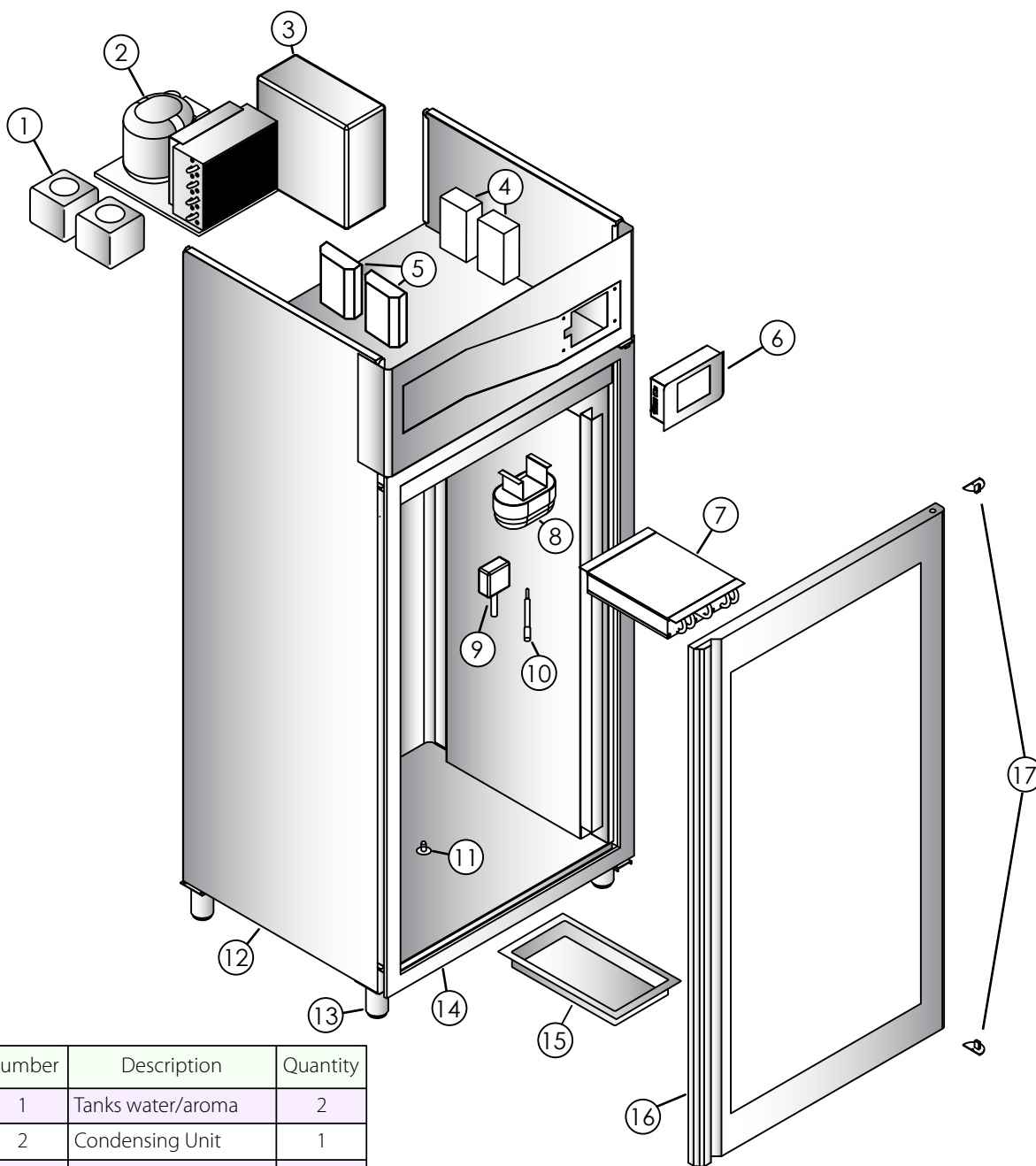

Number	Description	Quantity
1	Tanks water/aroma	2
2	Condensing Unit	1
3	Fumotic®	1
4	Transformer	2
5	PLC	2
6	Touch Controller	1
7	Evaporator	1
8	Internal Light	1
9	Humidity Probe	1
10	Ambient Probe	1
11	Steam Output	1
12	Unibody Frame	1
13	Adjustable Legs	4
14	Molding w/Heating	1
15	Drain Tray	1
16	Door w/Resistance	1
17	Door Hinge	2

⚠ DANGER

Gas Exposure
Do not damage the cooling system as it contains R404a refrigerant, which can cause injury, burns and frostbite.

RECEIPT INSPECTION

1.5

All Maturmeat™ units are factory tested for performance and are free from defects when shipped. The utmost care has been taken in crating this product to protect against damage in transit.

You should carefully inspect your Maturmeat™ unit for damage during delivery, even if the crate is free from damage. If damage is detected, you should save all the crating materials and make note on the carrier's Bill Of Lading describing this. A freight claim should be filed immediately. If damage is subsequently noted during or immediately after installation, contact the respective carrier and file a freight claim. Under no condition may a damaged unit be returned without first obtaining written permission (return authorization).

INSTALLATION

1.6

DANGER

Excessive Weight Hazard

Use two or more people to move and install your Maturmeat™. Failure to do so can result in back or other injury.

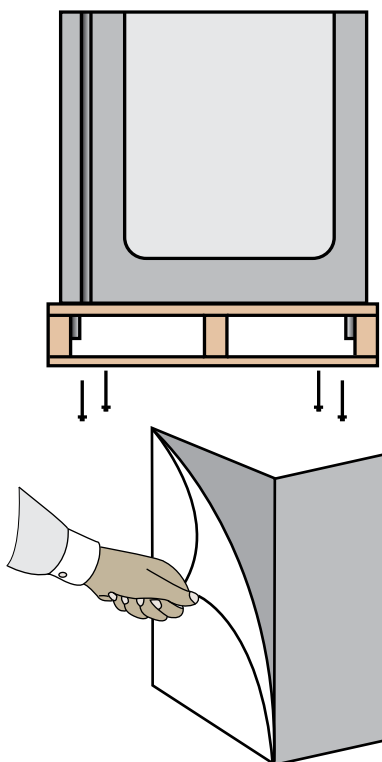

DANGER

Keep all packaging away from children

DANGER

Electrical Hazard
Never connect power to unit via extension cord or adapter, this can cause damage to the system and/or start a fire.

LOCATION:

Select a proper location away from extreme heat or cold. Space above the unit should allow for breathability to the condensing unit and access to the Water/ Aroma tanks. Allow enough clearance between the unit and the side wall in order to allow the doors to fully open.

PACKAGING:

The unit is shipped from the factory strapped to a sturdy wooden pallet and protected by MDF crating. The crating is attached to the pallet with nails and several screws. These should first be removed to avoid scratching the unit when lifting off the crating. To remove the Maturmeat™ from the wooden pallet start by cutting free the nylon bands. There are 4 bolts connecting the Maturmeat™ to the pallet, remove them to release the Maturmeat™ from the pallet.

Most exterior surfaces have a protective vinyl covering to prevent scratching during manufacturing, shipping, and installation, remove after installation and discard.

NOTE: DO NOT LAY THE UNIT ON ITS SIDE/BACK/FRONT DURING TRANSPORTATION OR INSTALLATION.

POWER CORD:

An attached power cord is provided without plug, shipped coiled inside the compressor compartment. For your safety and protection, have the installer connect the proper plug for your country by checking with the information on the data plate. Connect only to an appropriate dedicated 20 amp outlet.

POWER SUPPLY:

The supply voltage should be checked prior to connection to be certain that proper voltage for the cabinet wiring is available (refer to the data plate for the correct unit voltage). Make connections in accordance with local electrical codes. Use qualified electricians.

Use of a separate, dedicated circuit is required.

Size wiring to handle indicated load and provide necessary overcurrent protector in circuit (see amp requirements on the unit's data plate).

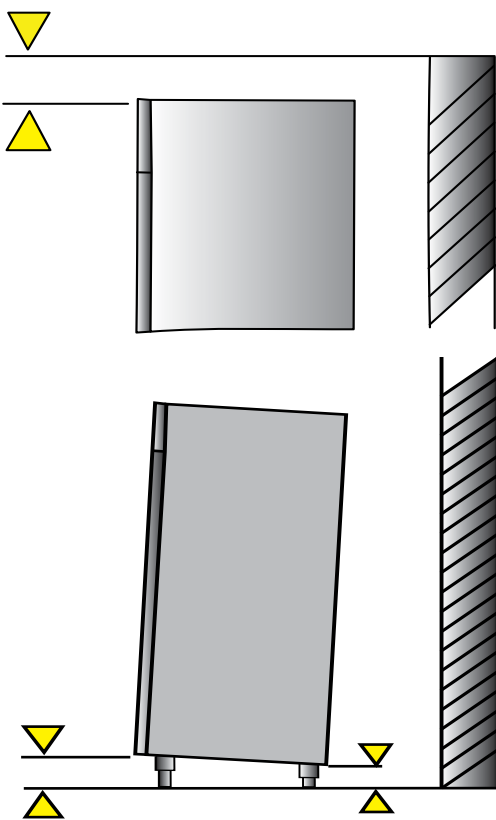

⚠ DANGER

Electrical Shock Hazard
if any damage to wiring is found,
do not touch and contact your
local service point. Failure to do
so can result in serious injury or
death.

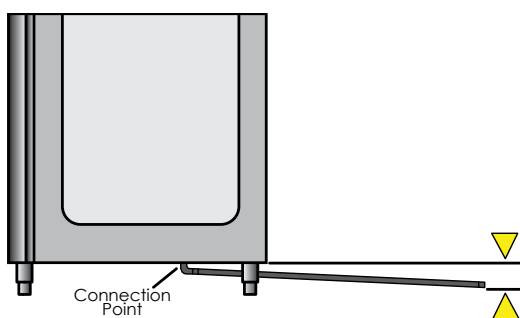

ELECTRICAL SCHEMATICS:

Refer to the electrical schematics on page 46-52 for any service work performed on the unit. Should you require a new one, please contact Maturmeat™ Service at produzione@arredoinox.it, and provide serial number of the unit involved.

CLEARANCE:

To assure optimum performance of your Maturmeat™ the condensing unit MUST have an adequate supply of air for cooling purposes. The operating location must have 30 cm (12") minimum clearance from the top of the Maturmeat™ to the ceiling.

Select a working location away from extreme heat or cold. The Maturmeat™ is designed to operate in temps of 89°F (32°C) or less. Locate the unit so that air drafts (such as heat, A/C or ventilation) do not blow on or over the top of the Maturmeat™.

ADJUSTING LEGS:

Unit includes 4 factory installed (except 100kg model). The ideal position for the unit should be that it leans towards the back, to allow for proper door closure. Adjust the leg by turning the lower portion of the leg. MATC100TF units will include 4 legs and 16 bolts packed inside the unit, these will need to be mounted and then adjusted.

VISUAL TEST:

Check the top of the unit making sure nothing has moved, shifted or loosened during transport. Check that all wires to PLC's are firmly connected, check lines on the condensing unit, check Fumotic® and lines to tanks.

Disconnect power to unit before performing visual test

PREPARE UNIT:

Fill the water tank with water to avoid false alarm. Slide the drain tray on the tracks underneath the unit, or set up the drain hose to connect to a floor or dedicated drainage system. Make sure that the end of the drain hose is a minimum of 5cm lower than the connection point. Before starting the test recipe, wipe down the inside of the unit in contact with food using a cloth or sponge, water and a non aggressive/non abrasive cleaner (for more information on cleaning, refer to page 26).

TEST RECIPE:

Maturmeat™ has a test recipe programmed under the My Recipe category. The test recipe must be run to ensure the Maturmeat™ performs all its functions. This is to prevent loss of product on first use. To set test recipe see page 9

REGISTER YOUR UNIT:

In order to validate your warranty please follow the link, <http://www.stagionello.it/authentication.php?back=my-account.php>

After a successful installation and with power to your Maturmeat™, the Climatouch® controller will start up automatically on the Welcome page.

The Welcome page allows you to select the language, and displays Firmware version installed. Note: Information may be displayed in Italian for the first time

From this screen, select the language you would like to use. You can change language at anytime by pressing the backward arrow from the Home page.

If needed, come back to the welcome page to check your firmware version, which can be found in the bottom left corner of the screen.

After selecting your language, you will land on the date and time page, where you can adjust the data should you need to.

To adjust the date or time, press the Set icon beside the corresponding field.

Use the up and down arrows above and below the numbers to adjust the month, day and year. Press the check mark to save and exit.

Use the up and down arrows above and below the numbers to adjust the hour and minute. Press the check mark to save and exit.

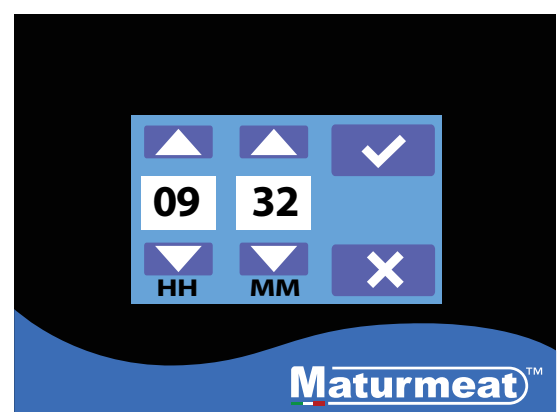
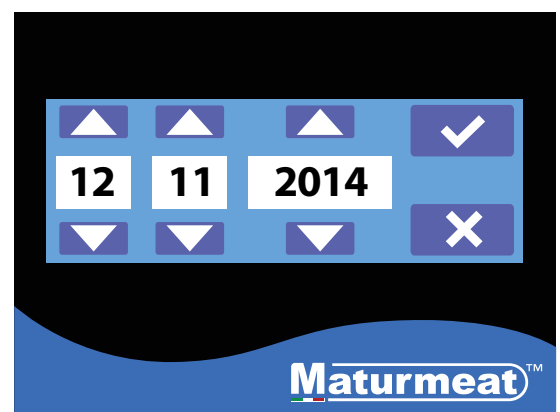
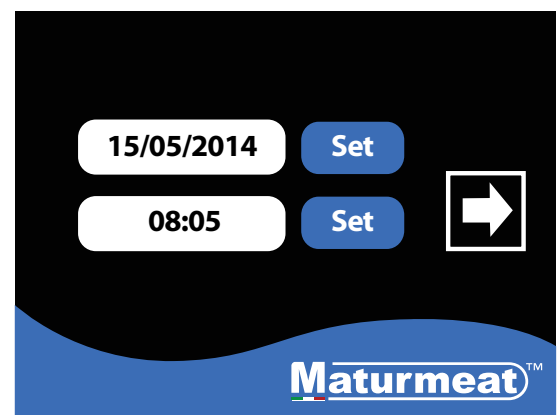
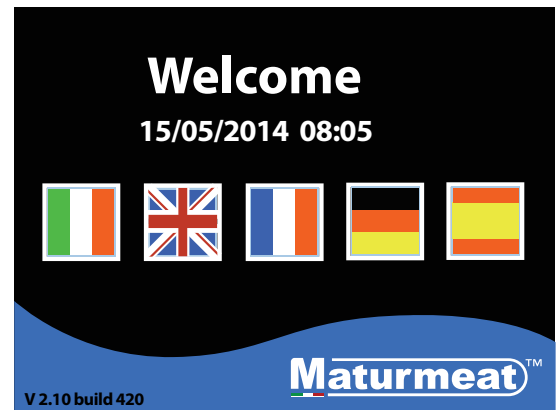



1. After setting date & time, press forward arrow.

2. This is the Home page, here you have 3 options to choose from:

- i. Customer,
- ii. Dealer,
- iii. Producer,

Select Customer to proceed.

3. In the customer area, you have 4 options to choose from:

- i. Climatic Recipes
- ii. HACCP-Performance
- iii. pH calibr.
- iiii. Variables

Select Climatic Recipes.

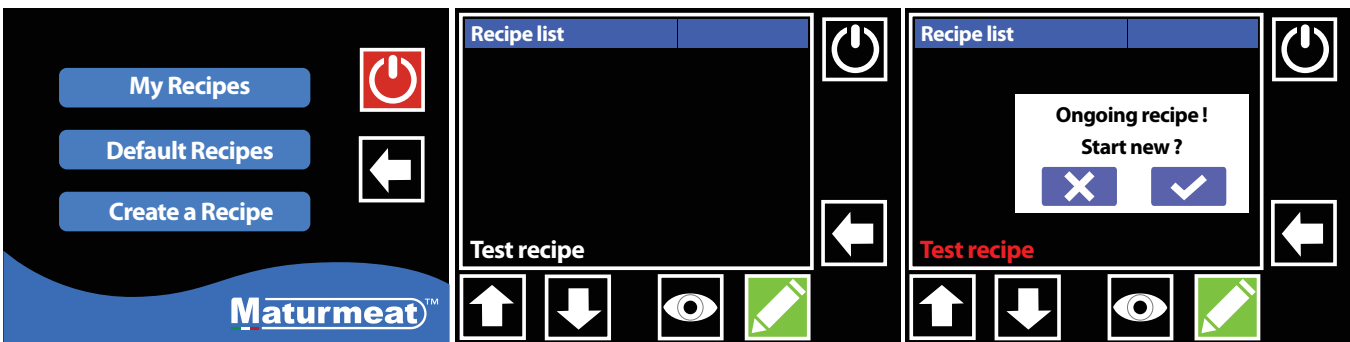

4. On the recipes page you can access all recipes; here you have 3 options to choose from:

- i. My Recipes
 - ii. Default Recipes
 - iii. Create a Recipe
- Select My recipes.

5. The test recipe is found at the bottom of the list; press the downward arrow until you see the recipe.

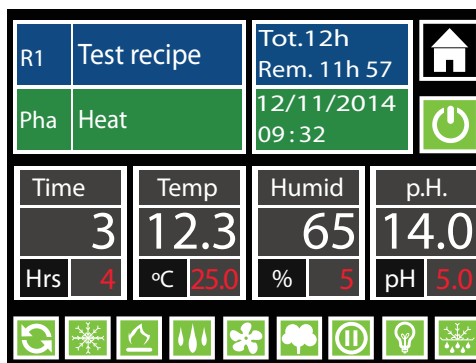

6. Highlight the test recipe in red, press the start button, a message will appear, press the check mark button to proceed.

7. The test recipe should automatically start. Look at the start/pause button to make sure its green.

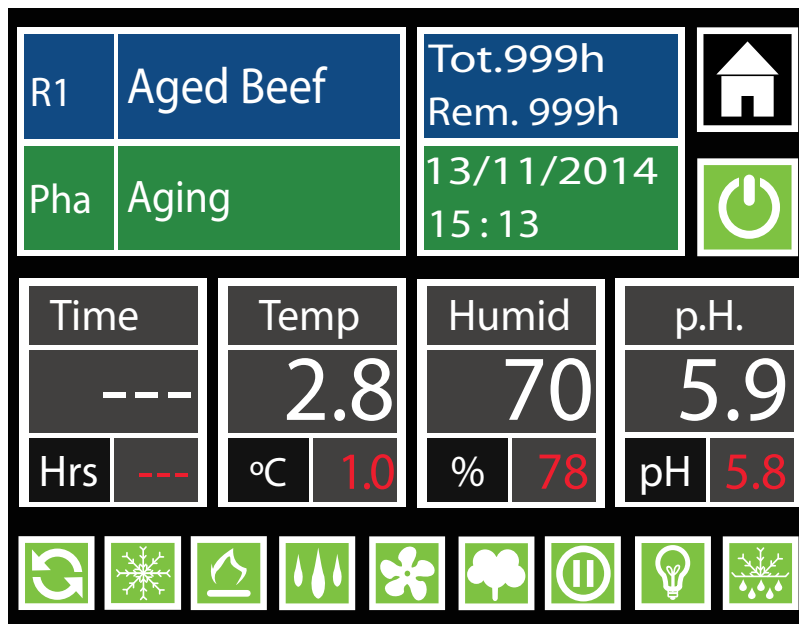

The following is an explanation of the recipe screen to help you understand the parameters you will be interacting with daily on the Maturmeat® controller. Alternatively, use the link to see the video online <https://www.youtube.com/watch?v=AfhtshDWTdl>



<table border="1"> <tr><td>R1</td><td>Beef</td></tr> <tr><td>PHA</td><td>Aging</td></tr> </table> <p>Recipe name currently in use Recipe phase currently performing</p>	R1	Beef	PHA	Aging	 Home icon: has 2 functions, exit recipe (when recipe is paused), check VTE/VTC values (while recipe is running)				
R1	Beef								
PHA	Aging								
<table border="1"> <tr><td>Tot.10h</td></tr> <tr><td>Rem. 9h 57</td></tr> </table> <p>Total time of the current recipe in use Remaining time of the recipe in use</p>	Tot.10h	Rem. 9h 57	 Start/Pause Recipe: Icon Green = recipe is working Icon Black = recipe is paused						
Tot.10h									
Rem. 9h 57									
<table border="1"> <tr><td>Time</td></tr> <tr><td>---</td></tr> <tr><td>Hrs</td><td>---</td></tr> </table> <p>Time remaining in current phase WHITE VALUE: displays time remaining in current phase. RED VALUE: displays total time in current phase</p> <p>Note: set value to 0 to skip phase when necessary</p>	Time	---	Hrs	---	<table border="1"> <tr><td>Temp</td></tr> <tr><td>12.3</td></tr> <tr><td>°C</td><td>20.0</td></tr> </table> <p>Temp for current phase WHITE VALUE: displays current temp inside unit. RED VALUE: displays temp set point needed to be reached.</p> <p>Note: There is +/- 2 range. Temp must be achieved before any other functions will work. It is normal to see humidity go out of range during cooling/heating</p>	Temp	12.3	°C	20.0
Time									

Hrs	---								
Temp									
12.3									
°C	20.0								
<table border="1"> <tr><td>Humid</td></tr> <tr><td>75</td></tr> <tr><td>%</td><td>50</td></tr> </table> <p>Relative Humidity for current phase WHITE VALUE: displays current humidity inside unit. RED VALUE: displays humidity set point needed to be reached.</p> <p>Note: There is +/- 7 range. Temp must be achieved before any other functions will work. It is normal to see humidity go out of range during cooling/heating</p>	Humid	75	%	50	<table border="1"> <tr><td>p.H.</td></tr> <tr><td>5.2</td></tr> <tr><td>pH</td><td>5.0</td></tr> </table> <p>pH for current phase (guide only) *WHITE VALUE: displays current pH value inside unit. RED VALUE: displays ideal value to be reached.</p> <p>*This value can only be read when pH probe has been purchased and connected.</p>	p.H.	5.2	pH	5.0
Humid									
75									
%	50								
p.H.									
5.2									
pH	5.0								

NOTE

Red value can be changed for the duration of the phase only, default values will reset once recipe advances into the next phase,



Air Cycling:

If the icon is green and the frame flashing, this indicates that the air inside the unit is being equalized to reduce cool/warm spots. All functions will be disabled for a set period of time. It is normal for the temp and humidity to go out of range during this time. The same key gives you the possibility of disabling or forcing an air cycle.



Cooling:

If the icon is green and the frame flashing, this indicates that cooling system is working to bring the temp down to the set point. The same key gives you the possibility of disabling or forcing the action.



Heating:

If the icon is green and the frame flashing, this indicates that the heating system is working to bring the temp up to the set point. The same key gives you the possibility of disabling or forcing the action.



Humidification:

If the icon is green and the frame flashing, this indicates that humidification system is working to bring the RH up to the set point. The same key gives you the possibility of disabling humidification. **Note when the unit needs to dehumidify, the humidification icon will change to the dehumidification icon.**



Dehumidification:

If the icon is green and the frame flashing, this indicates that dehumidification system is working to bring the RH down to the set point. The same key gives you the possibility of disabling dehumidification. **Note when the unit needs to humidify, the dehumidification icon will change to the humidification icon.**



Fan low/high speed:

If this icon is green with the green frame flashing, this indicates that the fan is working at a low speed; if the icon is blue with blue flashing frame, this indicates that the fan is working at a high speed. **Note you can toggle between high and low speed setting simply by pressing the fan icon.**



Aroma:

If the icon is green and the frame flashing, this indicates that liquid is drawn out of the aroma tank by the Fumotic®, nublized and sprayed into the unit. The same key gives you the possibility of disabling or forcing the action.



Rest/Recovery:

If the icon is green and the frame flashing, this indicates that the Maturmeat™ has disabled all functions for a set period of time to allow the product inside to rest. It is normal for the temp and humidity to go out of range during this time. The same key gives you the possibility of disabling or forcing the action.



Internal Light:

If the icon is green and the frame flashing green, this indicates the light inside the unit is switched on.



Defrost:

If the icon is green and the frame flashing, this indicates that the evaporator probe has detected a temp (set in the system variables) and has triggered a defrost. All functions will be disabled during the defrost period. It is normal for the temp and humidity to go out of range during this time. The same key gives you the possibility of disabling or forcing the action.

STARTING A DEFAULT CLIMATIC RECIPE

2.4

Follow the steps below to start a default climatic recipe. Alternatively, use the link to see the video online <https://www.youtube.com/watch?v=TPEB3mqgs7M>



1. From the Home page, Select Customer to proceed.

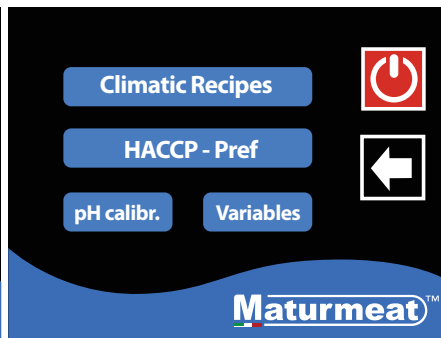

2. Select Climatic Recipes.



3. Select Default Recipes

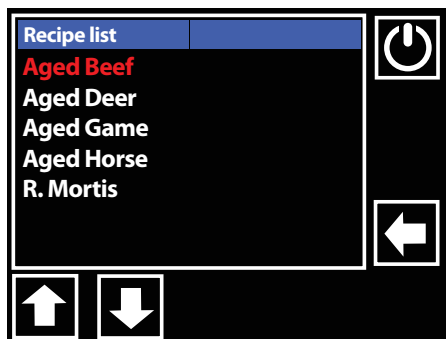

4. On this page you will find a list of 5 preset climatic recipes. Press the recipe name or use the down icon until you see the recipe you want to use.



5. With your recipe highlighted in red, press the start button, a message will appear, press the check mark button to proceed.

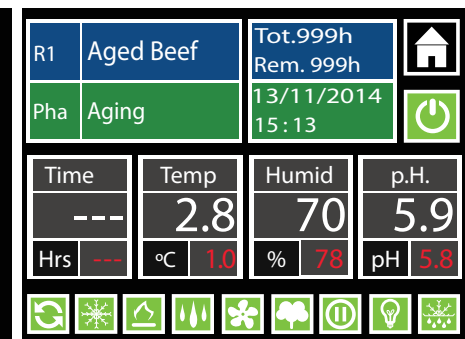

6. Your selected recipe should automatically start. Look at the start / pause button to make sure its green.

MODIFYING RECIPE PARAMETERS

2.5

Your production should be monitored daily, you may need and probably will have to, modify a recipe at some point, this could be due to several factors (meat type, meat quality, etc.). Follow the steps below to modify Time, Temp and Humidity parameters.

Modifications to default/saved recipes while in course are temporary and will last until the end of the phase, once the phase changes the parameters are returned to their preset value.

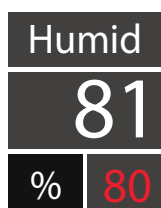

1. To change a set point, press the number in Red.

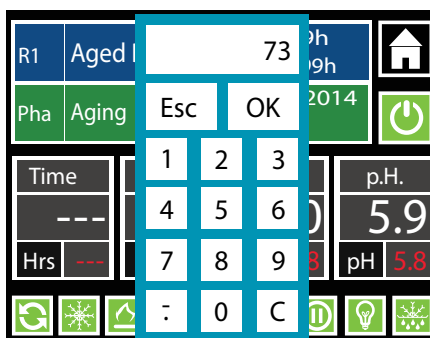

2. The keypad will appear, enter your value and press OK to temporarily save.

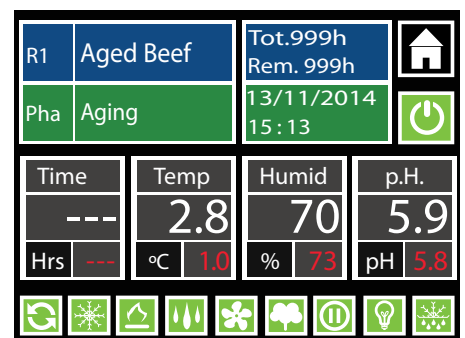



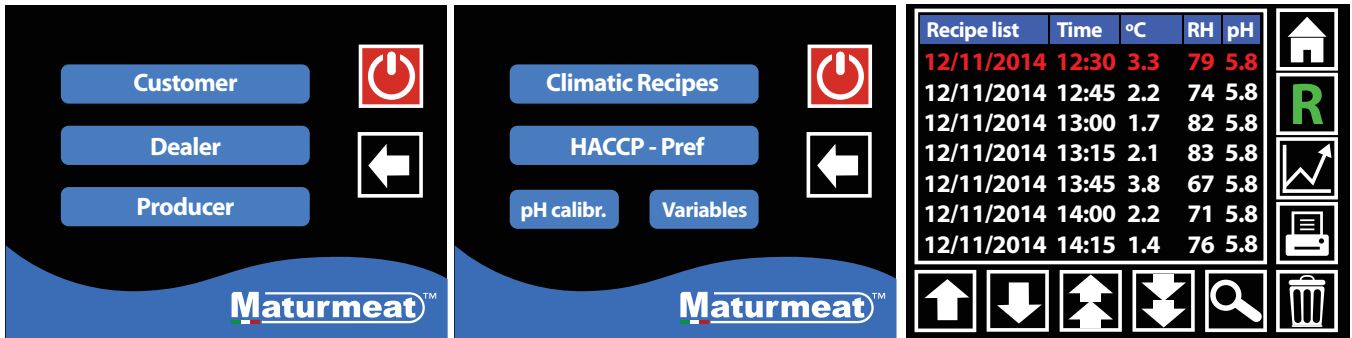







3. The recipe will continue with the new modified value until the end of the phase.



1. From the Home page, Select Customer to proceed.

2. Select HACCP-Pref.

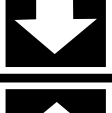
3. Here you can search, view and print production data.

	Home Icon: Pressing the home icon exits the HACCP-Performance page and returns you to the home page
	R Icon: Displays production data in line form. Press the R and it turns to an H. Note: while in R mode you cannot access the graphs, for this you must be in H mode
	H Icon: Displays the same production data (in green font), this data cannot be printed. At this point you can press graph icon to change to graph view.
	Print Icon: Line data can be printed via a specialized handheld printer purchased through your Stagionello™ distributor.
	Trash Icon: Delete line data.
	Search Icon: Line data can accumulate quickly, use the search icon to advance to a specific date.
	Page Down Icon: Quickly scroll down page by page.
	Page Up Icon: Quickly scroll up page by page.
	Down Icon: Scroll down one line at a time.
	Up Icon: Scroll up one line at a time.

Graph View:



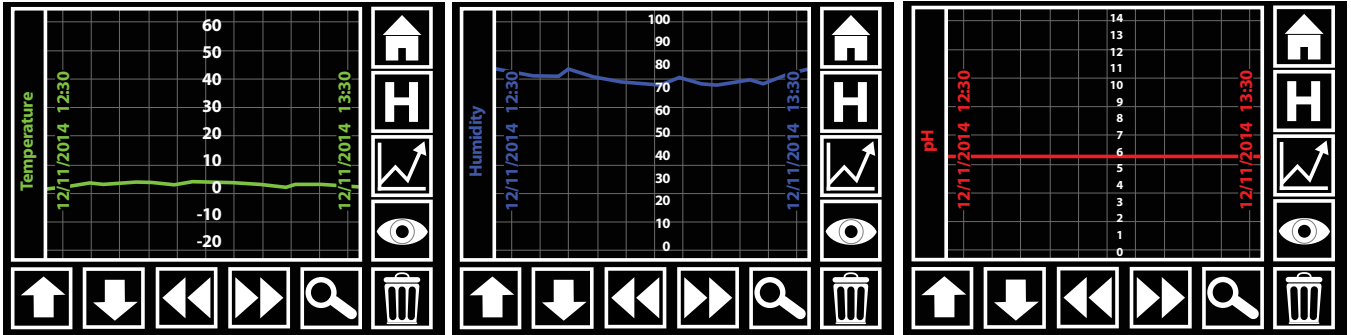





After switching to H mode, you can now access your production data in the form of a graph by pressing the graph icon. Temperature, Humidity and pH can be viewed here. You will notice that the print icon has been replaced by an Eye icon, this will allow you to toggle between 3 graphs.



Temperature Graph

Humidity Graph

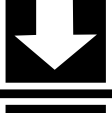
pH Graph

	Home Icon: Pressing the home icon exits the HACCP-Performance page and returns you to the home page
	H Icon: While in graph view, pressing H will exit graph view and return you to R mode (line data).
	Eye Icon: While in graph view, press the eye icon to toggle through the 3 graphs (Temp, Humidity, pH).
	Trash Icon: Delete data.
	Search Icon: Graph data can accumulate quickly, use the search icon to advance to a specific date.
	Forward Icon: Advance forward to the next section data.
	Backward Icon: Move backward to the next section data.
	Down Icon: Has no functionality on graph view.
	Up Icon: Has no functionality on graph view.

The following is an explanation to help you understand the parameters involved in creating a new recipe on the Climatouch® controller. Alternatively, use the link to see the video online <https://www.youtube.com/watch?v=-HKpifRFNWE>

Create Recipe Page 1.

On this page there are 2 sections to fill in:

1. Recipe Name
2. Number of sequential stages

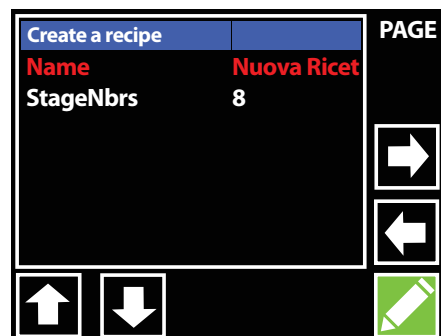

Create Recipe Page 2.

There are 16 recipe variables to create:

1. **Name:** Phase Name.
2. **Time:** Number of hours this phase should last.
3. **Temp(°C):** The average temperature that should be maintained during this phase.
4. **Humidity:** The average humidity that should be maintained during this phase.
5. **Ventilation:** Fan speed 0 = low speed, 1 = high speed.
6. **PH:** by setting a value here, you are creating a guideline. Note: in order for the climatouch® to read pH data in your product, the optional pH probe must be connected to the Maturmeat™.
7. **Aroma length(m):** by setting a value here, the liquid in the aroma tank will be drawn into the Fumotic® and will be nebulized and sprayed into the unit for the length of time (in minutes) set by you.
8. **Per.Aroma(h):** by setting a value here, you are setting the number of hours between each aroma activation.
9. **Recovery length(m):** all functionality is shut down to allow the product inside time to rest, this variable represents the amount of time in minutes that the rest/recovery will last.
10. **Recovery period(h):** this variable sets the number of hours between each rest/recovery period.
11. **Recycle length(s):** all functionality is shut down and the air inside is cycled in an attempt to equalize the climate, this variable represents the amount of time in seconds that the air cycle will last.
12. **Recycle period(m):** this variable sets the number of minutes between each air cycling period.
13. **Airenew length(m):** all functionality is shut down and the air inside is flushed out and fresh air is introduced into the unit, this variable represents the amount of time in minutes that the air exchange will last. *Note this works with the Air exchange kit (Standard on MATC150/400/800/300/600kg models only. Optional on MATC60/100/200/100+100kg models)*
14. **Airenew period(h):** this variable sets the number of hours between each air exchange period.
15. **Free Variable:** this doesn't need to be set, this represents an extra space for future addition of another variable.
16. **Overtime(h):** this variable extends the phase in case extra time is needed.

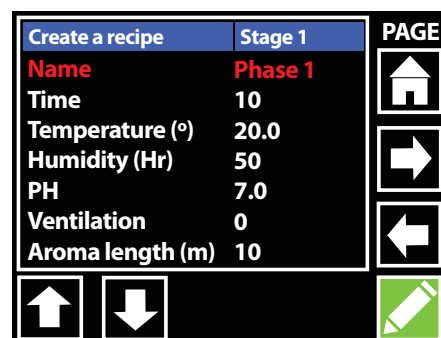

CREATING AND SAVING NEW RECIPES

2.9

This guide will help walk you through the process of creating and saving your own recipe. Alternatively, use the link to see the video online <https://www.youtube.com/watch?v=FQfpGkWbeNs>

The 3 tools you will use to modify the recipe parameters are:



Keyboard



Keypad



Check box

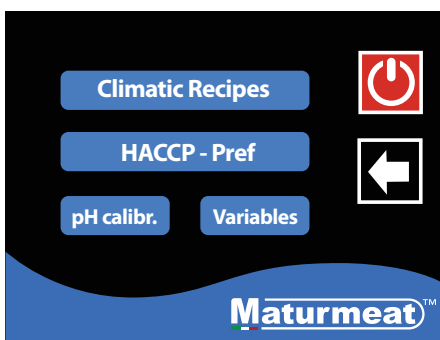

1. From the Home page, Select Customer to proceed.

2. Select Climatic Recipes.

3. Select Create a Recipe

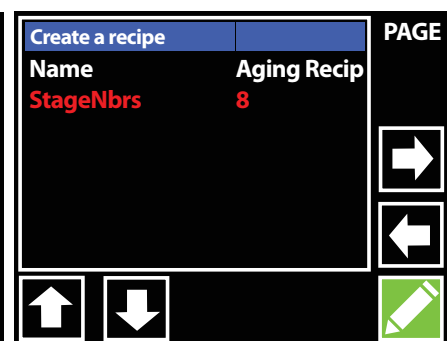
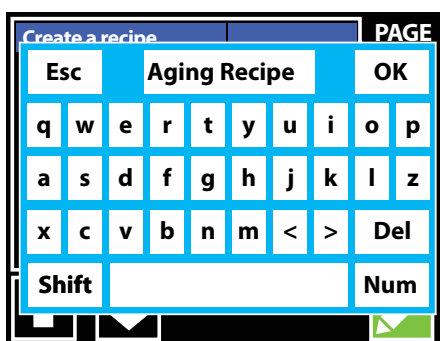

4. With the name field highlighted in red, Press the pencil icon to activate the onscreen keyboard and set your recipe name.

5. Use delete key to empty the field, type the name of your new recipe and press OK.

6. Use the down arrow to highlight the next field, press the pencil icon to activate the keypad to select the number of stages you want your recipe to have.

CREATING AND SAVING NEW RECIPES continued

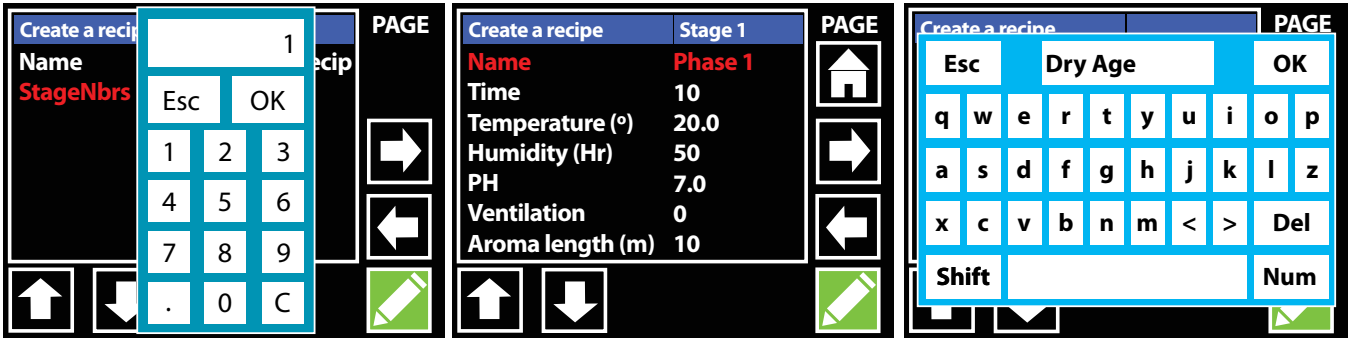

7. Enter the number of stages you want to your new recipe to have and press OK. If all the information you have entered is correct press the forward arrow to advance to the next page.

8. On this page you have *16 fields that can be modified (*with the exception of Free Variable this should be left 0). With the name field highlighted in red, press the pencil icon to activate the keyboard and set the name for this stage.

9. Use delete key to empty the field, type the name of this stage and press OK.

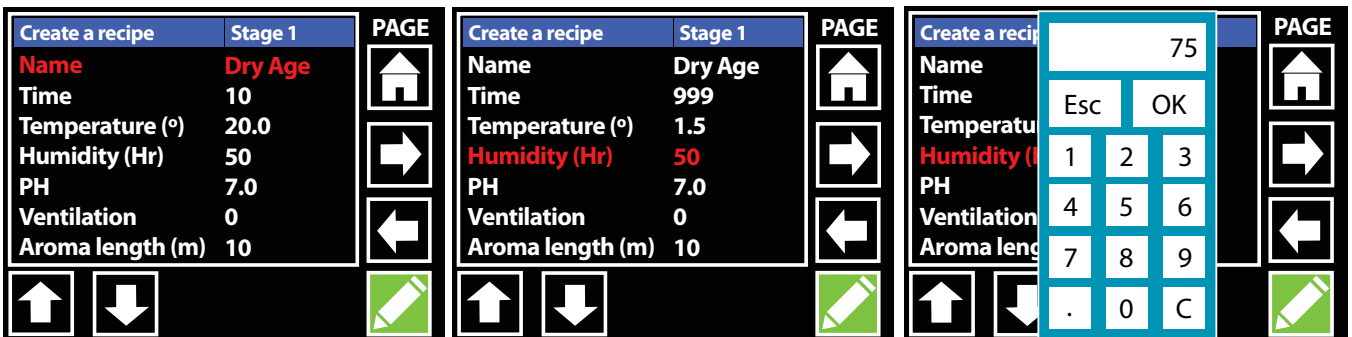

10. Use the down arrow to scroll through the recipe parameters, one by one, and adjust according to your needs.

11. You can skip ahead somewhat by pressing on the parameter to highlight it.

12. For the majority of the parameters, you will be working with the keypad to modify its value.

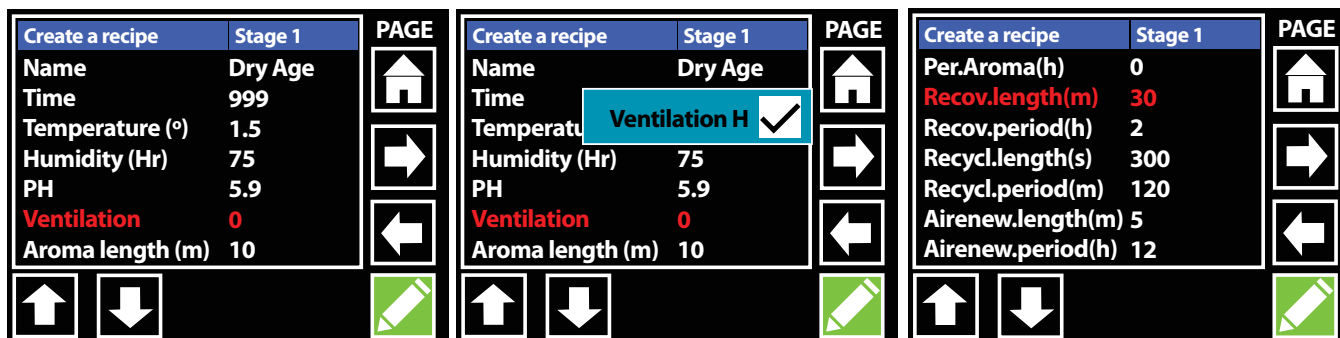

13. The ventilation or fan speed has 2 settings:
 0 = low speed
 1 = high speed
 Press the pencil icon to activate the check box.

14. By pressing on the empty box you will place a check mark inside, setting the fan on high-speed for this stage when needed.

15. The following Parameters can be left as is:
 Recov
 Recycl
 Airenew

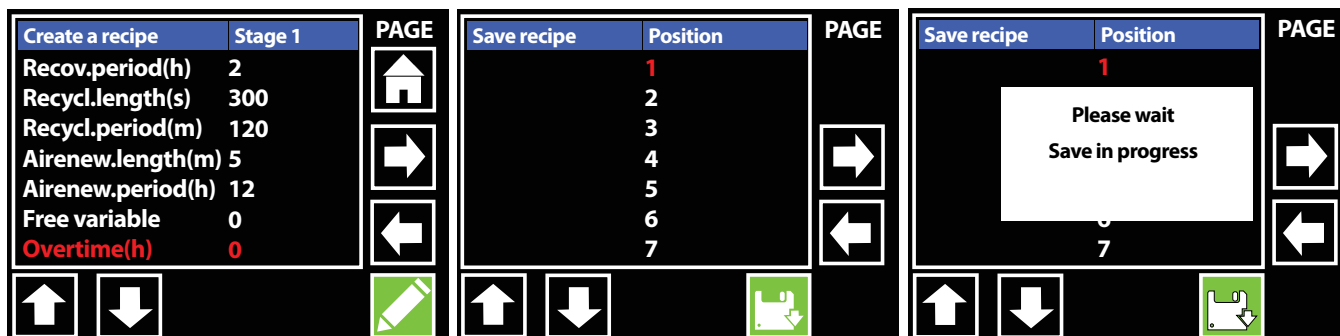

16. Once finished the current page, press the forward arrow to advance to the next page and repeat steps 8 - 15. Once you have filled in all parameters for all stages press the forward arrow to advance.

17. Once on the save recipe page, select the position to place your recipe and press the disk button to save.

18. A save in progress message will appear onscreen and may last a short while. Once save is complete you will automatically be returned to the Home page.

NOTE

The Airenew parameter is connected directly to the Air Exchange kit. This kit only comes standard on the MATC150/400/800/300/600kg models. On all other models the air exchange kit is optional.

NOTE

The Aroma parameters are connected directly to the Fumotic® and the aroma tank, if you do not use liquid flavoring (ie. Natural liquid smoke) in your recipe set the values to 0 to avoid false alarms.

2.10

STARTING A SAVED RECIPE

Follow the steps below to start a recipe that you have previously created and saved.



1. From the Home page, Select Customer to proceed.

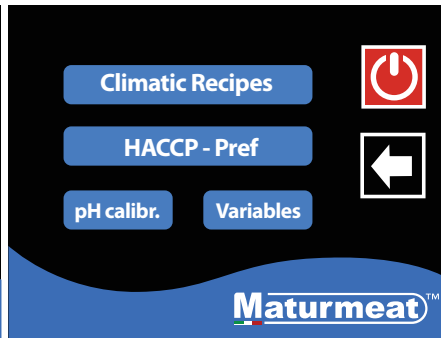

2. Select Climatic Recipes



3. Select My Recipes



4. Depending on how many recipes you've created and saved, you may have to use the down arrow to select the recipe you want.



5. With your recipe highlighted in red, press the start button, a message will appear, press the check mark button to proceed.

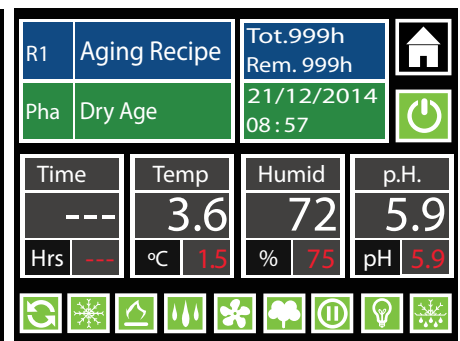

6. Your selected recipe should automatically start. Look at the start / pause button to make sure its green.

2.11

FORCING AROMA

Follow the steps below to force aroma anytime during a default climatic recipe or a recipe that you have previously created and saved.

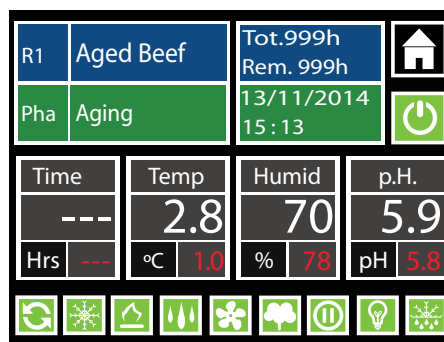

1. With your recipe running, press the aroma icon, the time selection box will appear onscreen.

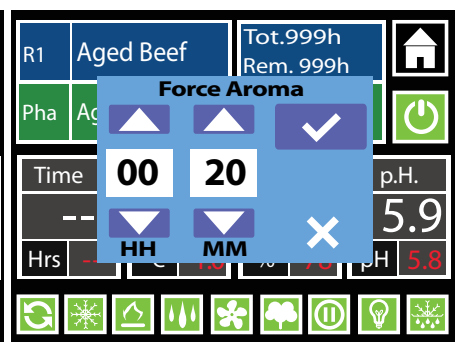

2. Using the up and down arrows, select the hours and/or minutes that you want liquid from the aroma / flavor tank to be nebulized by Fumotic® and sprayed into the unit.

Your Maturmeat™ has 3 standard probes that can be calibrated by you or by a technician. The probes are checked thoroughly before your Maturmeat™ leaves the factory. A certified instrument to measure either humidity and/or temperature must be used to calibrate the probes on your Maturmeat™. Follow the steps below to access the variables page to begin calibrating the probes, alternatively, use the link to see the video online <https://www.youtube.com/watch?v=TmPLBJ2aC4Q>

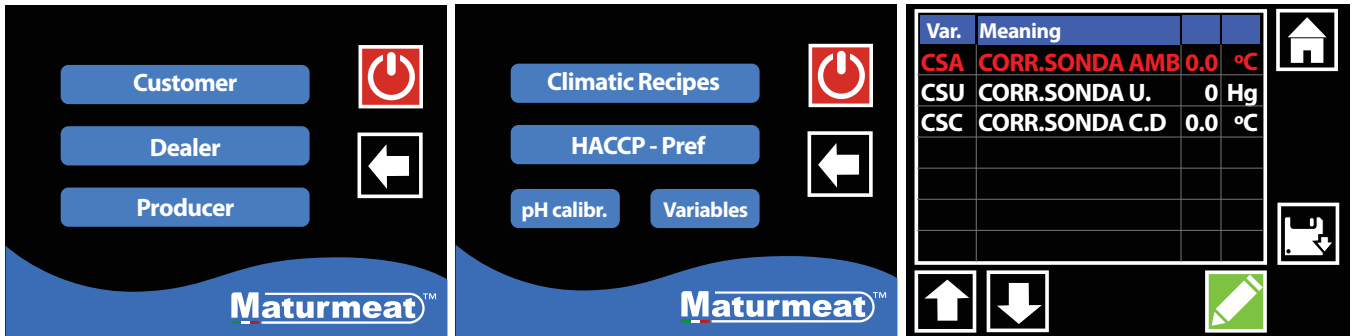

1. From the Home page, Select Customer to proceed.

2. Select Variables

3. On the variables page you will find 3 editable items:
 i. CSA - Ambient temp probe
 ii. CSU - Humidity probe
 iii. CSC - Condenser probe
 Highlight the variable in red and press the pencil icon to activate the keypad to select the corrected value.

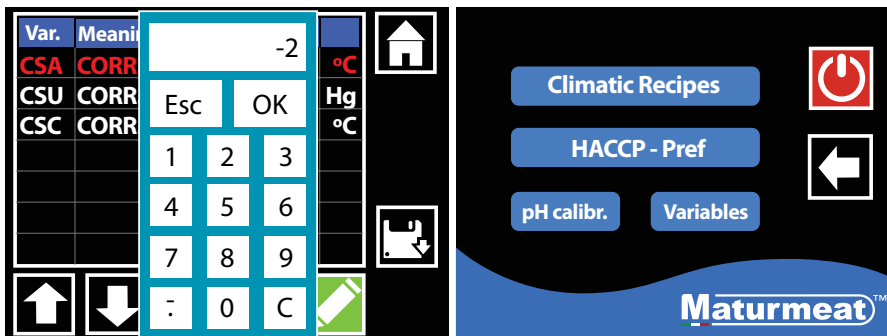

4. Use the keypad to enter the new value. The range of values that can be set are between -20...0...+20. Once value is set press OK. Press the disk icon to save and exit the variables page.

5. Press the start icon to get back to your recipe. Continue to take readings with the two probes (Certified probe and built-in Maturmeat™ probe) until both probes read the same.

NOTE

Comparison readings should be taken with the fan running and with the fan on pause. Take readings over a period of 5-10min.

NOTE

If you do not have a certified or professionally calibrated probe, please consult with a professional for assistance.

Your Maturmeat™ has an optional pH probe that can be purchased. The probe is checked thoroughly before your Maturmeat™ leaves the factory. A calibration system has been programmed into Climatouch® allowing you the possibility to calibrate your pH probe anytime. Follow the steps below to successfully calibrate your probe, alternatively, use the link to see the video online <https://www.youtube.com/watch?v=AkLgjoDq-G0>

Here is what you will need to calibrate the pH probe

1. pH probe
2. Buffer solution 4.01
3. Buffer solution 7.01
4. Water (small amount)
5. Container x 3 (ie.cups)
6. Paper towel/Napkins
7. Marker to label cups

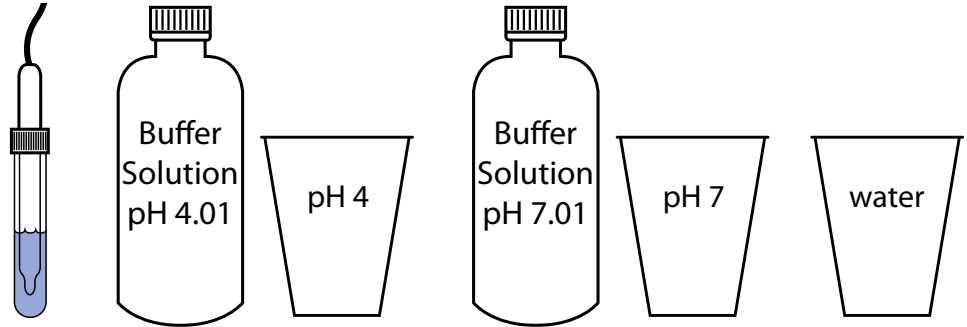

Because all of the fluids look alike it is best to label the cups to avoid confusion later on. Use the marker and write pH 4 or just 4 on the 1st cup.

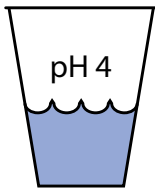

On the 2nd cup, use the marker and write pH 7 or just 7.

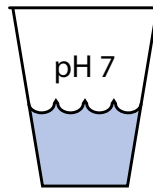

On the 3rd cup, use the marker and write water or just W. The water will act as a rinse between solutions.

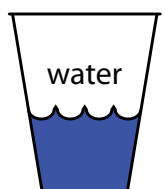

NOTE

Rinse probe with water between each recording of buffer solutions. Use paper towel/napkins with extreme care when drying probe, as probe's surface can easily scratch and become damaged producing false readings.

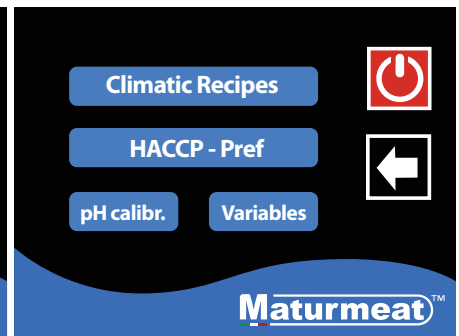

1. From the Home page, Select Customer to proceed.
2. Select pH calibr.

CALIBRATING pH PROBE continued

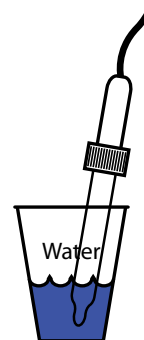
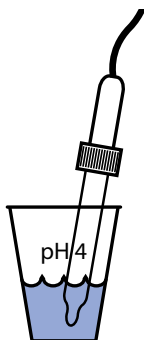
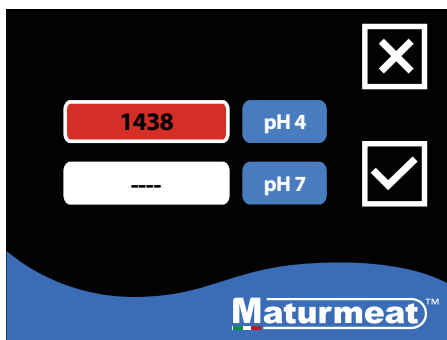

3. With the pH 4 field highlighted in red, Place the pH probe into the cup with the 4.01 solution, be sure to hold the probe so that it does not touch the bottom/sides of the cup. The correct pH 4 value will sit in the 1300 -1500 range. Once the value has stabilized press the pH 4 button to save and continue.

4. After recording in pH solution it is necessary to rinse the probe in water and gently dry with a napkin to reduce the chance of introducing pH 4.01 solution or water into the pH 7.01 solution.

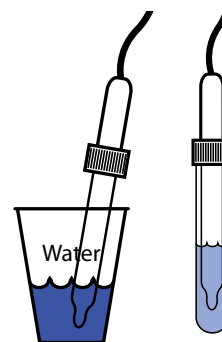
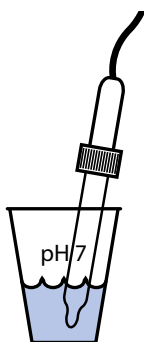
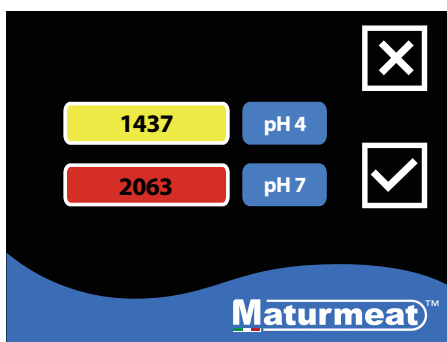

5. With the pH 7 field highlighted in red, Place the pH probe into the cup with the 7.01 solution, be sure to hold the probe so that it does not touch the bottom/sides of the cup. The correct pH 7 value will sit in the 1900 -2300 range. Once the value has stabilized press the pH 7 button to save.

6. After recording in pH 7 solution, rinse the pH probe in water one last time before placing it back into it's protective housing. Rinse out and partially fill pH probe's protective housing with fresh 4.01 buffer solution.

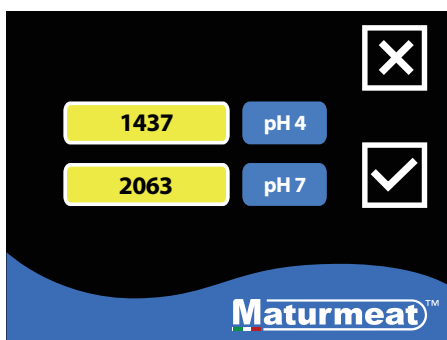

7. With both values saved, press the check mark icon to save and exit.

NOTE

Calibration of the optional pH probe is highly recommended each time a new production lot is started to ensure accuracy. If the probe has been sitting in its protective housing unused for 3 weeks or longer, it is highly recommended to calibrate the pH probe.

3.3

The Fumotic® is our patented system that enables you to introduce humidity when necessary. The water is drawn out of a tank situated on top of your Maturmeat™ and fed directly into the Fumotic®. The tank needs to be filled periodically, and should be checked daily, specifically before the end of the business day, or at any time when you will be away from the Maturmeat™ for an extended period of time. Doing this will help avoid triggering H₂O/Flavour level alarms. The aroma tank works on the same principal but uses a flavoring liquid instead of water to introduce into your recipe, this can be added manually during a default climatic recipe or preprogrammed into a custom made recipe.

⚠ DANGER

System Damage
 Use zero solid residue liquids only, do not use corrosive or explosive liquids; do not use liquids that increase in volume when heated. Failure to do so can cause damage to the unit and /or the user.

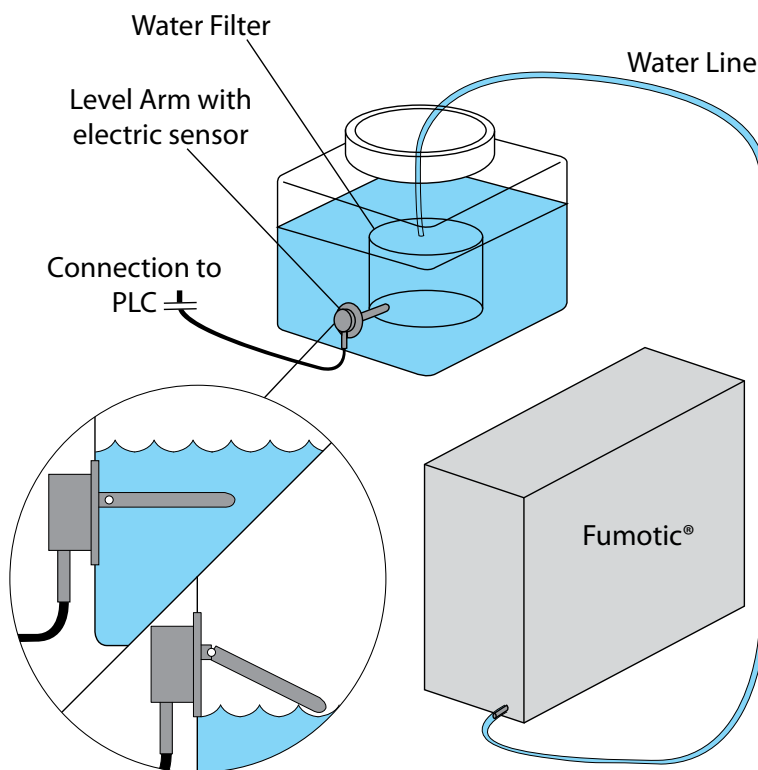

November 2013 - Present

3.4 WATER FILTER

This chart shows the maximum duration of the filter's life based on the Hardness of water passing through it.

°fH	ppm, mg/L	dGH, °dH	gpg	°e, °Clark	Max.Duration
9	0.9	16.07	15.41	12.83	220L
18	1.8	32.13	30.82	25.65	110L
27	2.7	48.20	46.22	38.48	80L
36	3.6	64.26	61.63	51.30	60L
45	4.5	80.33	77.04	64.13	50L

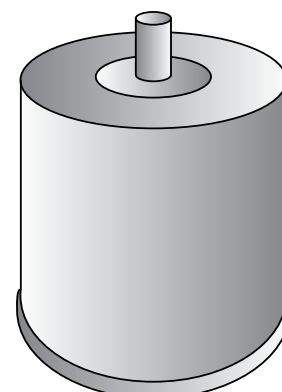

Water Filter:

The contents of the filter and bacteriostatic housing itself meets the most stringent quality standards certified by the FOOD AND DRUG ADMINISTRATION (title 21, section 173.25, paragraph A, sub-paragraph 1). The filter's nylon fabric with a filtration level of 150 microns complies with directive EEC 128/1990 and certified to FDA standards (title 21, paragraph 177). The homopolymer polypropylene structure is also FDA certified.

NOTE

The water used in conjunction with the Fumotic® should have a low mineral content to prevent calcium build up inside the Fumotic®. Calcium buildup inside the Fumotic® can create many problems, please contact a local Maturmeat™ service point for assistance.

FUMOTIC® REAR VIEW

3.5

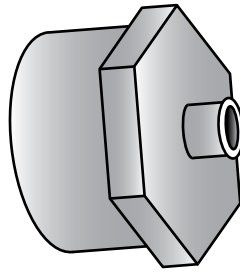
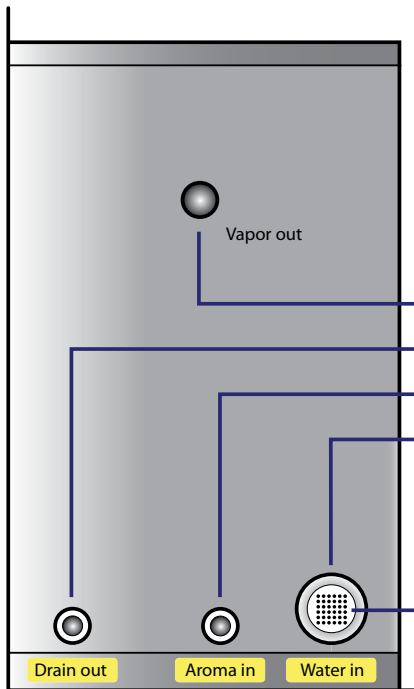

Reducer:

This adapter is connected on your Fumotic® to allow for the waterline from the Water tank to be connected.

- Vapor out:** connects inside the unit to add humidity or aroma/ flavor
- Drain out:** expels any overflow from Fumotic®
- Aroma In:** connects directly to aroma/ flavor tank
- Water In:** connects directly to water tank, dual purpose connection can be connected to direct waterline
- Screen:** prevents large particles from entering the fumotic, this is not a substitute for a filter.

Direct Connect:

The waterline connected to the Fumotic® is dual purpose. From the factory, the water tank is connected, but this can be removed and connected directly to a dedicated waterline. See page 23 for instructions.

FUMOTIC® FRONT VIEW

3.6

- Level probe sensitivity adjustment:** This should not be touched
- Level probe inverter:** This should not be touched
- Breaker switch:** A safety measure to prevent overloading of the circuit, can also be used to manually shut off the Fumotic®
- Vapor discharge:** manual discharge of vapor
- 12 Point connection:** (12 pin twin model, 9 pin all other models)
- 4 point connection:** Connector for tank level system

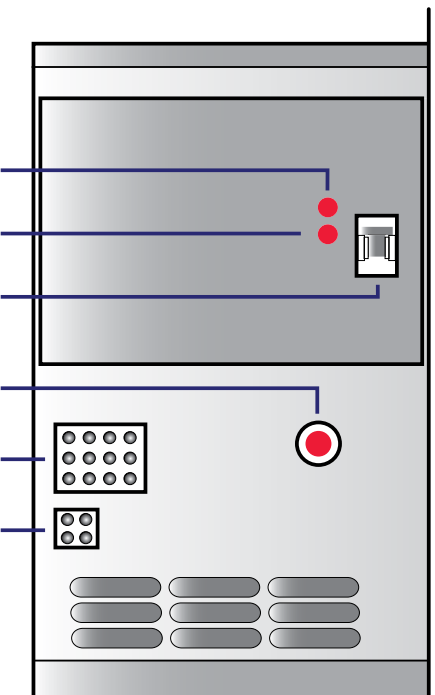

3.7

HOW TO CONNECT DIRECT WATERLINE TO FUMOTIC®

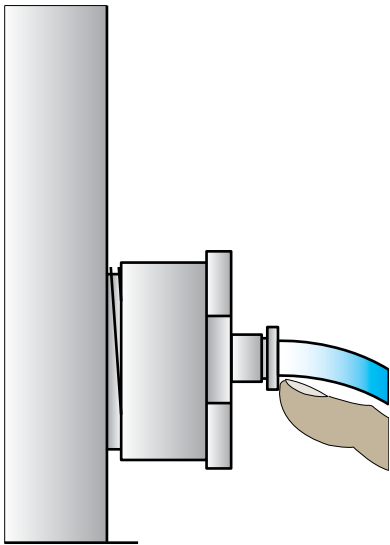

1. Push on ring around water tube and pull hose.

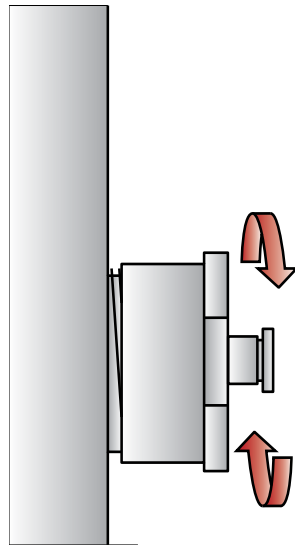

2. Unscrew and remove reducer.

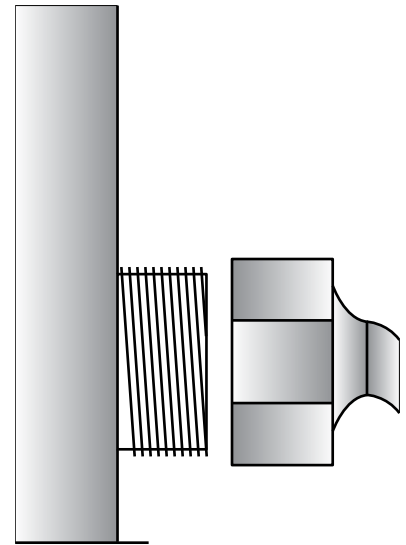

3. Connect using a standard water hose connection 3/4", do not over tighten

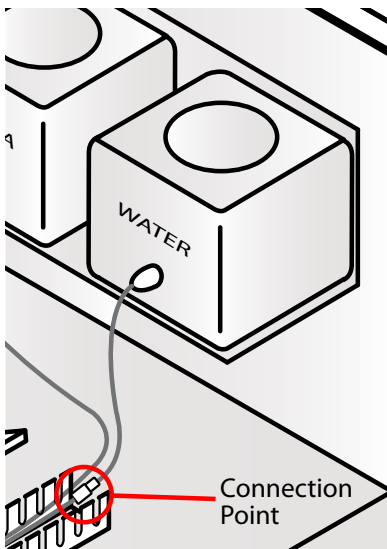

4. From water tank, follow level sensor wire until you reach the wiring duct. Open wiring duct and locate connection point.

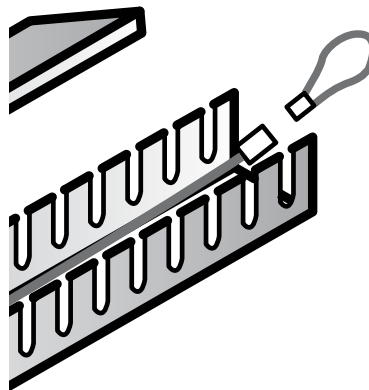

5. Disconnect line and insert the closed loop.

⚠ DANGER

Electrical Shock Hazard
Unplug/Disconnect power before touching wiring of any kind. Failure to do so can result electric shock or death.

6. Place wiring neatly back in wiring duct

7. Turn on water supply, and check for leaks.

8. Turn power back on to unit.

3.8

SCALE FORMATION INSIDE FUMOTIC®

Scale build up is caused by the high mineral content in your water also know as "Hard water". Scale build up inside the Fumotic® will reduce performance and cause severe damage. Should scale build up inside your Fumotic® contact your local Maturmeat™ service point for assistance, the process to remove scale from the system requires removal of the Fumotic® and the use of solutions to dissolve the scale and fluids to clean and purify the system rendering it safe for use with food. Be advised that the manufacturers warranty is voided when scale/calcium is found anywhere in the humidification system from the tanks leading into the Fumotic® to inside of the Maturmeat™ itself.



DANGER

Shock Hazard

Before attempting to clean any part the unit, unplug the unit's power or shut down power to the unit if connected directly to an electrical panel, failure to do so can result in serious injury or death.

Cleaning Maintenance:

Cleaning your Maturmeat™ should be done as often as needed. AISI 304 stainless steel has a layer of oxide preventing rust. Using abrasive and/or corrosive detergents can deteriorate this layer. Internal and external stainless steel surfaces must be washed with water and mild neutral soap.

In case of bad odors, use a vinegar and water solution to clean the entire surface. Rinse thoroughly then dry the surface with care.

Rounded Corners:

All vertical corners are rounded to provide simple and easy clean up. The rounded corners also prevent the build up of fine particles that may otherwise become trapped.

Condensing Unit:

All condensing units require regular maintenance. The purpose of the condenser is to release absorbed heat; If the condenser coils are clogged with dirt or the fins are bent it restricts or block air flow through the coils and interferes with the heat exchange. This causes the system to work harder and shortens the life of your compressor. Please check your condensing unit regularly. Please unplug the unit's power or shut down power to the unit if connected directly to an electrical panel before attempting to clean. You can use compressed air to clear away and loose dirt or dust that may impair normal use.

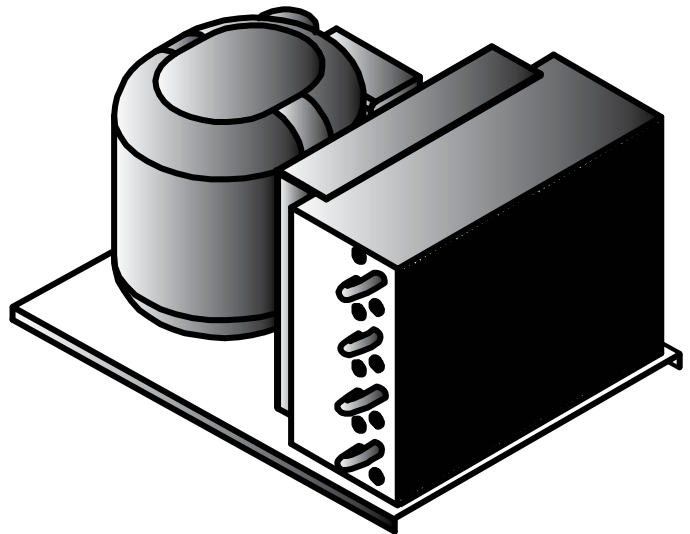
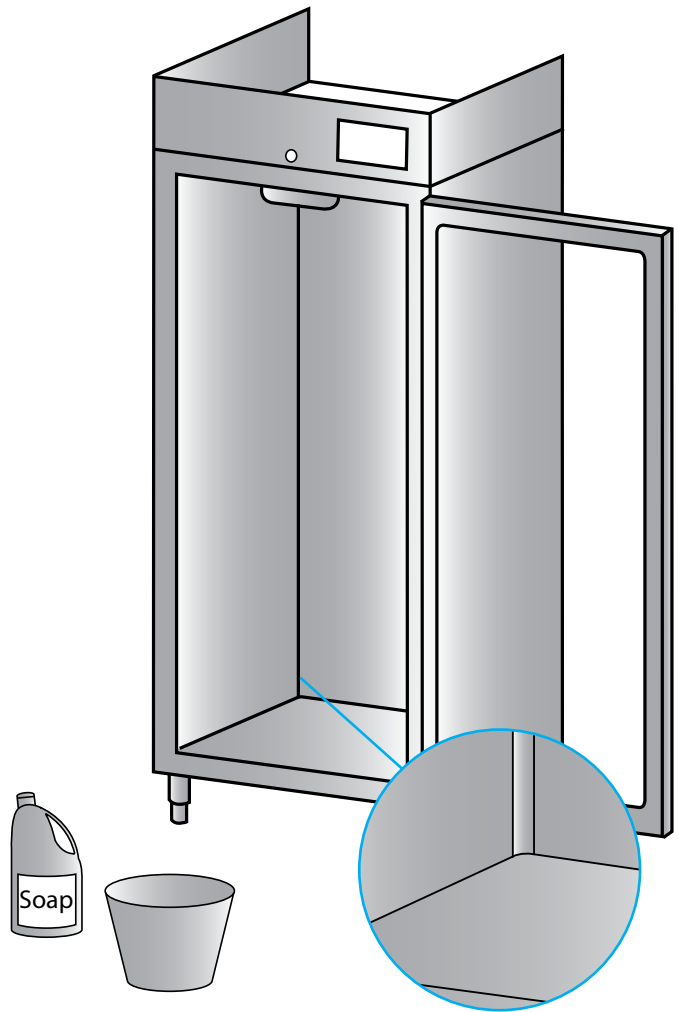

CHANGING THE LIGHT

3.10



DANGER

Shock Hazard

Before attempting to change the light bulb, unplug the unit's power or shut down power to the unit if connected directly to an electrical panel, failure to do so can result in serious injury or death.

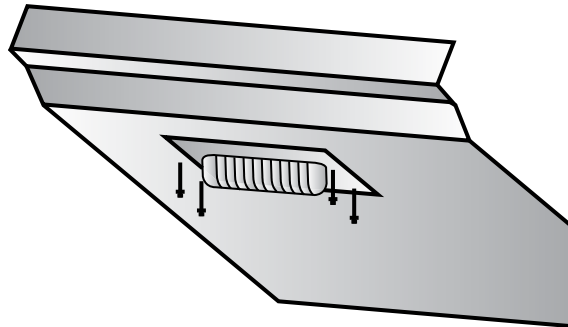

Light Bulb Replacement:

Inside your Maturmeat™ you will find a Light bulb set in a protective glass enclosure. In order to change the bulb, unscrew the 4 screws on the mounting plate holding the protective glass cover. Once removed, carefully set aside mounting plate and glass cover, remove the halogen bulb. When installing the new bulb, be sure not to touch the glass with your fingers leaving behind oils that will burn out the new bulb.

Light Bulb Type:
E27 - 28W

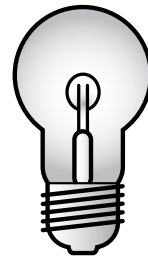

EMPTYING THE DRAIN TRAY

3.11



DANGER

Slip Hazard

Overflow from the drain tray as a result of neglecting to empty it can result in serious injury or death.

Your Maturmeat™ has a tray, which collects excess water moisture. The tray should be emptied daily to avoid overflowing onto your floor creating the possibility of unsafe or unsanitary conditions in your workplace.

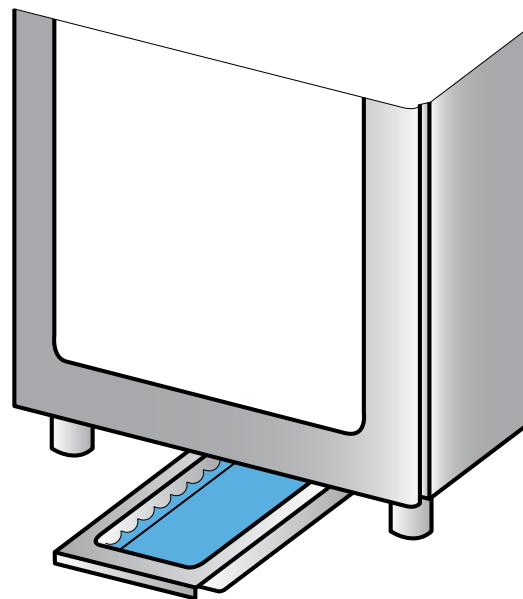

You can cross reference the follow variable codes with the list found on pages 36 - 41

Heating and cooling is managed in the neutral zone on the basis of the temperature set point and the temperature differentials (parameters DTNC and DTNF). Cooling is activated when the set point $+(DTF \text{ value})$ is exceeded and remains enabled until the set point is reached (with $DTNF = 0$). Heating is activated when the temperature goes below the set point $-(DTNC \text{ value})$ and remains enabled until the set point is reached (with $DTNC = 0$). It is possible to set a "dead zone" with the parameters (DTNC) and (DTNF) which de-activates heating and cooling when the temperature is between the set point $-(DTNC)$ and the set point $+(DTNF)$.

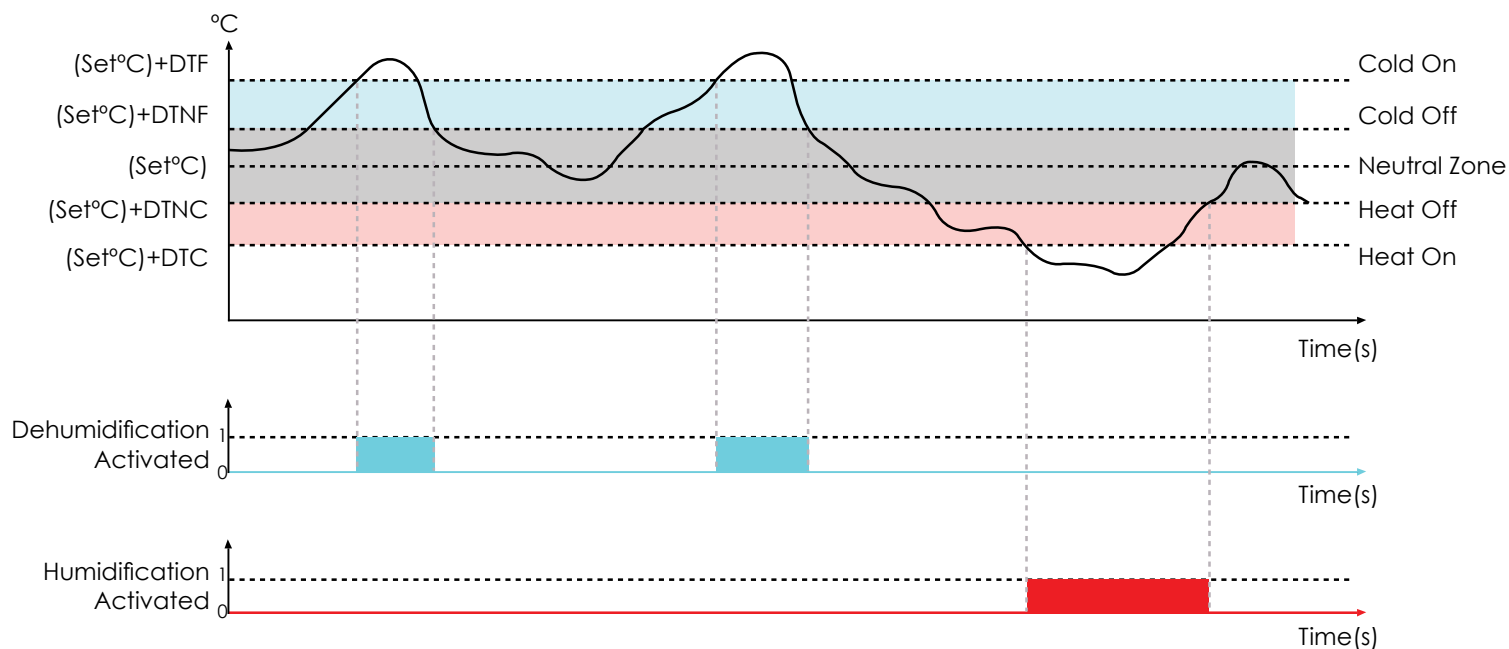

The parameter (TSF) creates a delay between the cooling system's switch off and it's subsequent re-activation. Heating can be deactivated with the parameter CA (CA = 0 disables the heating relay under all conditions).

You can cross reference the follow variable codes with the list found on pages 36 - 41

Humidification and dehumidification is managed in the neutral zone on the basis of the humidity set point and the humidity differentials (parameters DUU and DUD). Dehumidification is activated when the set point $+(DUD)$ value is exceeded and remains enabled until the set point is reached (with $DUNS = 0$). Humidification is activated when the humidity value falls below the set point $-(DUU)$ value and remains enabled until the set point is reached (with $DUNI = 0$). It is possible to set a "dead zone" with parameters $(DUNS)$ and $(DUNI)$ which deactivates humidification and dehumidification when the humidity is between the set point $-(DUNI)$ and the set point $+(DUNS)$. Humidification and dehumidification management can be excluded with the variables (U) and (DE) . With the (HR) variable you can decide whether to show the humidity value on the display or not.

There are three dehumidification modes found in parameter (DEU) :

0. Dehumidify with cooling (cooling is activated to dehumidify, heating is activated only to maintain the ambient temperature;

1. Dehumidify with heating (heating is activated to dehumidify, cooling is activated only to maintain the ambient temperature;

2. Separate dehumidification (the dehumidification system is activated without the use of heating and cooling, they will only be activated in the event of thermoregulation).

It is possible to set a limit on the dehumidification phase with parameter (LDE) by flagging an alarm.

It is possible to set a limit on the humidification phase with parameter (LUM) by flagging an alarm.

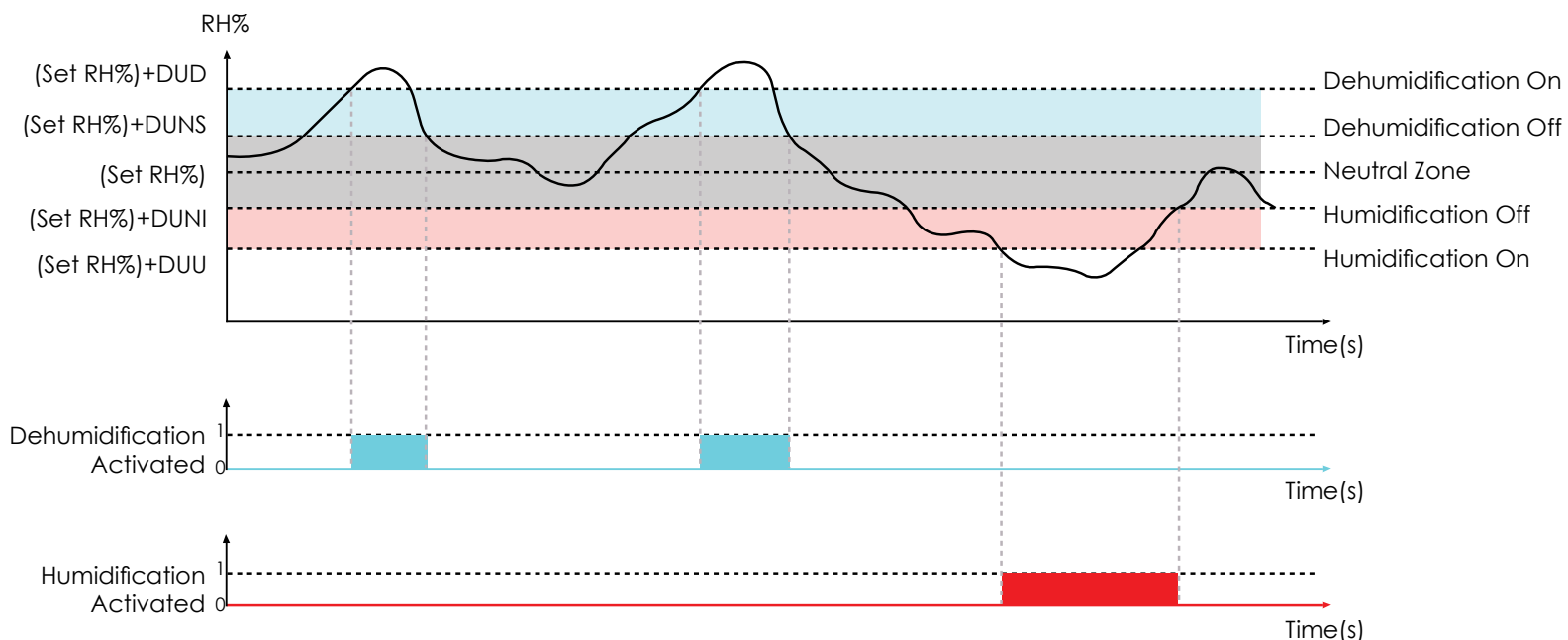

3.14

Please follow these directions closely, failure to do can result in complete failure of the device your trying to update, be sure to connect and disconnect cables when power is OFF, or unless otherwise directed.

What you will need before starting.

- Copy of the latest firmware
- Hyperterminal software
- RS232 Cable
- RS232 to USB Cable
- 7mm wrench



Step 1.

- With a computer connected to the internet, connect the RS232 to USB Cable to install drivers.
- Open Hyperterminal.exe program or download form internet and install on your computer.



Step 2.

- Before continuing stop any running program on Maturmeat® and unplug the power cord.
- Use 7mm wrench to remove cover on the back of the display controller.



Step 3.

- With NO power to Maturmeat® connect the RS232 cable to the display controller

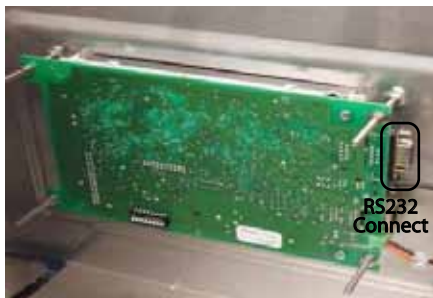

Step 5.

- Start Hyperterminal and begin to configure the connection.
- Page 1 enter name (ie. 2.13).
- Page 2 select the com port on your computer where your cable is connected.
- Page 3
 - Bit per second: 57.600
 - Bit Data: 8 bit
 - Parità/(parity): Nessuno (none)
 - Bit di Stop: 1
 - Controllo Flusso: Nessuno (none)



Step 6.

- On the back of the Display put Dip Switch number 8 on ON/UP position, to allow Port Connection (Leaving all the other switches OFF/DOWN).
- Plug in Maturmeat®'s power cord the display controller's screen will be white.



Step 7.

- From the PC's keyboard press "1" DOWNLOAD IMAGE TO THE.... A string of letters will come up on screen.
- From the top of the window select trasferimento (Transfer) then Invia file (send file).
- press SFOGLIA/browse and select file to be uploaded (ie. 2.13.bin)
- Select Ymodem for the Protocol then Invia (send).

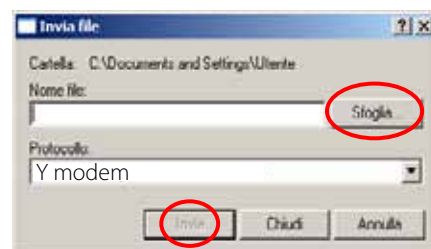
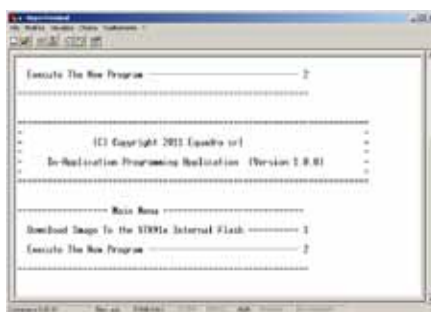

NOTE

- A loading screen will appear, when the counter reaches 11seconds the download will begin and usually takes about 2 minutes to complete.
- With Windows 7 & 8 the main window on hyperterminal may remain white in this case press the "1" key twice so you can proceed.

Step 8.

- Once successfull, go to the back of the Display, set the Dip Switch number 8 to the OFF/DOWN position.
- Unplug the power cord.
- Disconnect the RS323 Cable from the display controller.



Step 9.

- Put cover back on and fasten with nuts.
- Plug in Maturmeat®'s power cord.
- On the display controller go to Producer enter the password 4825 and select Variables to verify all the values are correct and save.
- Finally you can go back into the recipe and continue production.

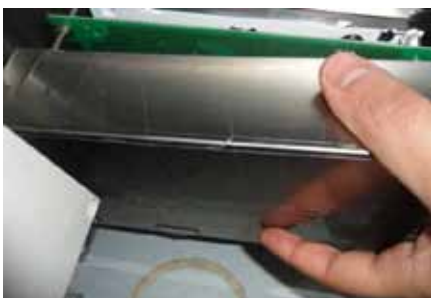

3.15

Please follow these directions closely, failure to do can result in complete failure of the device your trying to update, be sure to connect and disconnect cables when power is OFF, or unless otherwise directed.

What you will need before starting.

- Copy of the latest firmware
- Flashloader demonstrator software
- USB to TTL Cable
- Philips head screwdriver



Step 1.

- With a computer connected to the internet, connect the TTL Cable to install drivers.
- Open Flashloader.exe program or download form internet and install on your computer.



Step 2.

- Before continuing stop any running program on Maturmeat® and unplug the power cord.
- Use Philips head screwdriver to remove cover on the PLC.
- With NO power to Maturmeat® connect the TTL cable to the PLC.



Step 3.

- On the back of the PLC card you will find a small black connector (jumper), Normally the jumper covers 1 pin only.
- Make sure to cover both pins with the jumper in order to enable connection mode.
- After all connections are made Plug in Maturmeat®'s power cord.

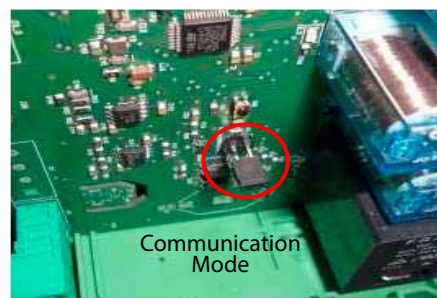
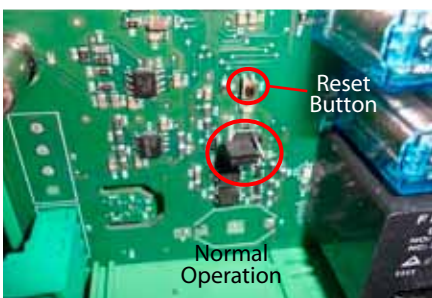

Step 4.

- Start Flashloader and begin to configure the connection.
- Page 1 Select Com Port
Baud Rate: 115.200
Time Out (S): 5
Parity: Even
Echo: Disabled
- Page 2 The PLC will be read quickly if successful the Target Readable message will appear in the window, if not press the reset button on the PLC just above the jumper.

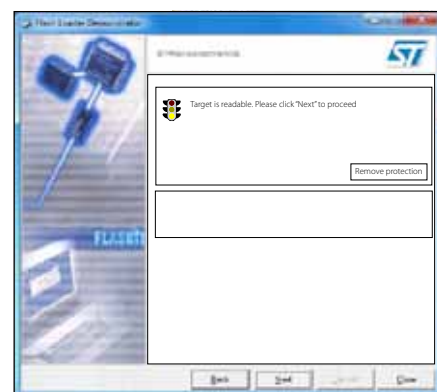

FIRMWARE UPDATE PLC'S continued

Step 5.

- Page 3 From the target drop down box be sure to select 64K .



Step 6.

- Page 4 Go to the "Download to device" section.
- Page 4 Select the file to update , download the PLC firmware (ie. PLCStagionello134.hex).
- Page 5 the download will start on its own, once complete "download successful" will appear.



Step 7.

- Unplug Power Cord Before Removing Cables.
- Make sure to disconnect the jumper from both pins (Communication mode) and cover 1 pin only (Normal operation).

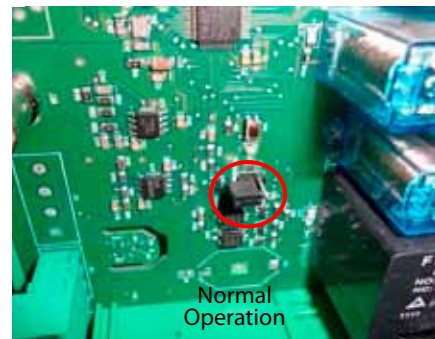
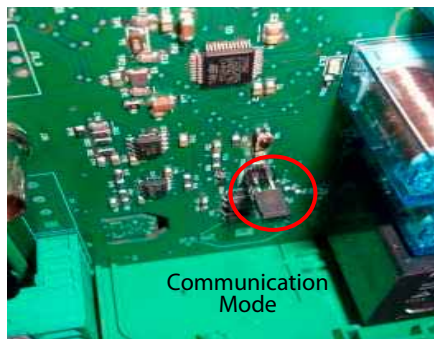

Step 8.

- Place cover on PLC and replace screws.
- Follow the same procedure to update the 2nd PLC.
- Once both PLC's have been updated Plug in Maturmeat@'s power cord.



Alarm Code	Description	Possible Cause/ Recommendations
E00	Ambient probe failure	<ul style="list-style-type: none"> · Check the ambient probe's state · If the problem persists, replace the probe
E01	Humidity probe failure	<ul style="list-style-type: none"> · Check the humidity probe's state and connections · Calibrate using a secondary Probe or replace probe if necessary
E02	Evaporator probe failure (in this case any defrost cycle will last for the time set in the defrost variable)	<ul style="list-style-type: none"> · Check power to evaporator probe · If the problem persists, replace the probe
E07	Low freon level	<ul style="list-style-type: none"> · Check the amount of freon in system
E08	High Freon pressure	<ul style="list-style-type: none"> · Check the condenser fan or the thermostatic expansion valve · Make sure that the condenser is clean
E09	Humidification time exceeded	<ul style="list-style-type: none"> · Check the humidifier operation
E10	Dehumidification time exceeded	<ul style="list-style-type: none"> · Check the freon pressure · Check for ice on the evaporator
E11	Door Open	<ul style="list-style-type: none"> · Check the door/s are closed · Check the door switch
E12	Condenser high temperature alarm	<ul style="list-style-type: none"> · Check the temperature on top of unit · Check if the condenser fan is working · Check if the condenser is clean

TROUBLESHOOTING continued

Alarm Code	Description	Possible Cause/ Recommendations
E13	Thermal protection compressor failure	· Check power to the compressor
E15	Maximum or minimum humidity alarm	· Check the humidity probe for correct operation · Calibrate using a secondary certified probe or replace probe if necessary
E16	Air exchange failure	· Check power to the air exchange kit
E17	Condenser probe failure (If the probe is broken, the condenser low temperature control for fan shut-down is not taken into consideration)	· Check the state of the ambient probe and calibrate using a secondary certified probe · Replace probe if necessary
E18	Minimum or maximum temperature alarm.	· Check the state of the compressor · The probe does not read the temperature correctly or the compressor's stop/run command is not working.
E20	Fan one stopped	· Check that variable AV1 is set to 0
E21	Fan two stopped	· Check that variable AV2 is set to 0
E22	Low level H ₂ O/Aroma	· Refill tank with corresponding liquid
E23	No Power	· This alarm will only appear as a code once power is restored

Variable	Description	Value	Default
DTC	HOT temperature differential This refers to the main SET-POINT. It is expressed in an absolute value and defines the temperature hysteresis for HOT with reference to the temperature SET POINT.	Diff. Minimum 0.2 Diff. Maximum 10	2.0 °C
DTF	COLD temperature differential This refers to the main SET-POINT. It is expressed in an absolute value and defines the temperature hysteresis for COLD with reference to the temperature SET POINT.	Diff. Minimum 0.2 Diff. Maximum 10	2.0 °C
DTNC	Hot temperature NEUTRAL zone This refers to the main SET-POINT. Heater is not enabled in the neutral zone.	Diff. Minimum 0.0 Diff. Maximum 3	0.2
DTNF	Cold temperature NEUTRAL zone This refers to the main SET-POINT. Cooling is not enabled in the neutral zone.	Diff. Minimum 0.0 Diff. Maximum 3	0.1
DUU	HUMIDIFICATION differential This refers to the humidity SET-POINT. It is expressed in an absolute value and defines the humidification hysteresis with reference to the humidity SET POINT.	Diff. Minimum 1 Diff. Maximum 10	7%
DUD	DEHUMIDIFICATION differential This refers to the humidity SETPOINT. It is expressed in an absolute value and defines the dehumidification hysteresis with reference to the humidity SET POINT.	Diff. Minimum 1 Diff. Maximum 10	7%
DUNS	Upper humidity NEUTRAL zone This refers to the main SET-POINT. Humidification is not enabled in the neutral zone.	Diff. Minimum 1 Diff. Maximum 10	5
DUNI	Lower humidity NEUTRAL zone This refers to the main SET-POINT. Dehumidification is not enabled in the neutral zone.	Diff. Minimum 1 Diff. Maximum 8	7

SYSTEM VARIABLES continued

Variable	Description	Value	Default
IS	Interval set in hours between defrost periods.	0h.....24h 0 DISABLED	2h
DS	Maximum defrost duration (minutes).	Min 1 minute Max 60 minutes	20 min
TS	Defrost temperature. Defrosting is carried out until the temperature read by the evaporator probe is achieved (if the probe fails to read temp, the defrost is completed with the DS set time)	-50°C.....+100°C	10°C
SGO	Drainage duration (minutes) At the end of the defrost cycle, cooling, dehumidification and fan systems are stopped for the set SGO time.	0 min.....20 min 0 DISABLED	0 min
PV	FAN PAUSE After defrosting and after draining (if set in SGO), the delay countdown begins.	0 min.....20 min 0 DISABLED	0 min
ABT	Low temperature alarm This allows a minimum ambient temperature value to be defined. An alarm will be set off below the ABT temperature; the alarm will appear onscreen, and an audible beep will sound the existence of the anomaly. The alarm is triggered after the RAT time.	ABT < -50°C = OFF ABT < AAT by 1.0	-8°C
AAT	High temperature alarm This allows a maximum ambient temperature value to be defined. An alarm will be set off above the AAT temperature; the alarm will appear onscreen, and an audible beep will sound the existence of the anomaly. The alarm is signalled after the RAT time. The alarm does not interrupt any defrosts in progress.	AAT > 200°C = OFF AAT > ABT by 1.0	8°C
ABU	Low humidity alarm This allows a minimum humidity value to be defined for the space to be humidified. The alarm is activated below the ABU value, the alarm will appear onscreen, with an audible beep. The alarm is triggered after the RAU time.	ABU < AAU by 1% ABU < 1% = OFF	0%
AAU	HIGH humidity alarm This allows a maximum humidity value to be defined for the ambient to be humidified. The alarm is activated above the AAU value, the alarm will appear onscreen, with an audible beep. The alarm is triggered after the RAU time.	AAU > ABU by 1% AAU > 99% = OFF	100%

SYSTEM VARIABLES continued

Variable	Description	Value	Default
VTE	Evaporator probe temperature displayed (temp will not be displayed if ESE = 0).	Temperature	Read Only
VTC	Condenser probe temperature displayed (temp will not be displayed if ESC = 0).	Temperature	Read Only
M	Door switch input status (with door closed).	0=NO 1=NC	1
AG	Aroma water input status.	0=NO 1=NC	0
PVS	Fan pause during defrosting.	0=fans not operating 1=fans operating	0
AVA	Fan enablement during aroma.	0=DISABLED 1=ENABLED	0
AVF	Fan enablement during cooling.	0=DISABLED 1=ENABLED	1
RAT	Alarm notification time delay for minimum or maximum temperature.	0=INSTANTANEOUS 0<=OFF 0 min...240 min	60 min
RAU	Alarm notification time delay for minimum or maximum humidity.	0=INSTANTANEOUS 0<=OFF 0 min...240 min	30 min
VMC	Fans in continuous operation. If enabled during defrosting they stop if PVS=0.	0=DISABLED 1=ENABLED	0
TSF	Minimum time between cooling shut off and the next subsequent switch on. It also stops the fans if they are not enabled for other functions.	0 min...10 min 0 DISABLED	1 min
DEU	Dehumidification mode selection Separated dehumidification enables hot and cold only for temperature.	0=COOLING 1=HEATING 2=SEPARATE DEHUMIDIFICATION	0
U	Enable Humidification.	0=DISABLED 1=ENABLED	1
DE	Enable Dehumidification.	0=DISABLED 1=ENABLED	1

SYSTEM VARIABLES continued

Variable	Description	Value	Default
CSA	Ambient probe value correction.	-20°C.....0.....+20°C	0
CSU	Humidity probe value correction.	-20%.....0.....+20%	0
CSC	Condenser probe value correction.	-20°C.....0.....+20°C	0
CA	Enable Heat.	0=DISABLED 1=ENABLED	1
HR	Humidity management. If disabled, the humidity is not shown on the display.	0=DISABLED 1=ENABLED	1
ESE	Exclude evaporator probe.	0=DISABLED 1=ENABLED	1
ESC	Exclude condenser probe.	0=DISABLED 1=ENABLED	1
SBR	Defrost type, cycle inversion (with hot gas), resistance or static. The cold output is also enabled with hot gas. Static defrost will still reach the temperature the end of the defrost cycle.	1=HOT GAS 0=RESISTANCE 2=STATIC	1
LST	Minimum value that can be attributed to the temperature set point.	-50°C.....+200°C LST < HST by 1°C	-3°C
HST	Maximum value that can be attributed to the temperature set point.	-50°C.....+200°C HST > LST by 1°C	35°C
DBF	Temperature differential with reference to the set point for COLD BLOCK. This constitutes the SET -DBF limit below which the cooling start relay and the Dehumidification relay are disabled.	0°C.....+40°C	0°C
DBC	Temperature differential with reference to the set point for HOT BLOCK. This constitutes the SET +DBF limit above which the heating start relay and the Humidification relay are disabled.	0°C.....+40°C	0°C
RATC	Alarm time delay for maximum condenser temperature.	0<= OFF 0=INSTANTANEOUS 0 min.....240 min	3 min
LDE	DEHUMIDIFICATION time limit. If dehumidification fails to reach the humidity SET POINT within the LDE time, an alarm will be triggered.	0 min.....240 min 0=DISABLED	0

SYSTEM VARIABLES continued

Variable	Description	Value	Default
VU	Fan enablement during humidification. This function is directly related to the humidifier.	0=DISABLED 1=ENABLED	1
BVC	Condenser fan stop. If the BVC is higher than the condenser probe reading, the fan stops. This function also takes into consideration hot gas defrosting.	0°C.....130°C BVC<0°C = OFF	10°C
DVC	Allows condenser fan to restart after this many degree points.	1°C.....30°C	5°C
RAP	Door/s open alarm delay. A value below 0, disables the alarm. A value of 0 creates an instant alarm. Once alarm is triggered all functionality is stopped except alarm and internal light.	0 min.....120 min	1 min
AMTC	Condenser maximum temperature alarm. AMTC is not blocked by BVC if there is an overlap.	0°C.....130°C >130°C OFF	48°C
DMTC	Condenser max temp alarm must drop this many degree points before alarm does not reappear onscreen.	1°C.....30°C	10°C
FC	Duration of cooling cycle enablement. If the ambient probe fails, it works for a total FC minutes. The FC countdown starts at the end of the PFC time.	0 min.....120 min 0=DISABLED	15 min
PFC	Pause cooling cycle. This variable is only considered by FC time.	0 min.....120 min 0=DISABLED	5 min
LR	Coolant level inlet status.	0=NO 1=NC	0
PF	Freon high pressure inlet status.	0=NO 1=NC	0
LUM	Humidification time limit. If humidification fails to reach the humidity SET POINT within the LUM time, an alarm will be triggered.	0 min.....120 min 0=DISABLED	0
VC	Enable hot ventilation only.	0=DISABLED 1=ENABLED	1
TF	Cold thermal inlet status.	0=NO 1=NC	0
LO	Air change inlet status.	0=NO 1=NC	0
ESPH	Exclude PH probe.	0=DISABLED 1=ENABLED	1

SYSTEM VARIABLES continued

Variable	Description	Value	Default
CSPH	PH probe correction.	-5.00.....0.00.....+5.00	0
DU	Disable humidity inlet status.	0=NO 1=NC	0
DFD	Disable cold + dehumidification inlet status.	0=NO 1=NC	0
DCUF	Disable hot+humidifier+smoke inlet status.	0=NO 1=NC	0
SDY	Stand-by inlet status.	0=NO 1=NC	0
AV1	Fan 1 malfunction alarm. If enabled, this function allows me to send an alarm when fan 1 stops or if sensor 1 is disconnected.	0=DISABLED 1=ENABLED	0
AV2	Fan 2 malfunction alarm. If enabled, this function allows me to send an alarm when fan 2 stops or if sensor 2 is disconnected.	0=DISABLED 1=ENABLED	0
VDE	Enable fans in dehumidification only.	0=DISABLED 1=ENABLED	0
BTUS	Block defrost temperature reading.	0=DISABLED 1=ENABLED	0
BTUR	Block softening temperature reading.	0=DISABLED 1=ENABLED	0
BTUA	Block air change temperature reading.	0=DISABLED 1=ENABLED	0
HACF	HACCP data storage frequency.	0.....240 min	240
FAHR	Change temp value to display in fahrenheit.	0=DISABLED 1=ENABLED	0
DPHP	Positive pH differential.	0.....14	14
DPHN	Negative pH differential.	0.....14	14
EPSU	Screen lock enable/disable.	0=DISABLED 1=ENABLED	0
PSWU	Screen lock Password.	Default	1234
PSWD	Dealer Password.	Default	****
PSWP	Manufacturer Password.	Default	****

MATURMEAT™ SPECIFICATIONS

4.2

The Maturmeat™ line is entirely built in AISI 304 stainless steel CE certified to be used in contact with a food. The technical specifications and models are described in the table below:

Model	Size	Temp Range	Voltage	Hz	Kw	Amp	Noise	Kg	Door
MATC150TF	90 X 78 X 211	-3°C+35°C	230 +/-10%	50/60	3.99	17.3	<72	200	1
MATC060TF	110 X 78 X 132	-3°C+35°C	230 +/-10%	50/60	2.80	11	<72	150	2
MATC100TF	73 X 78 X 211	-3°C+35°C	230 +/-10%	50/60	2.37	10.8	<72	140	1
MATC200TF	140 X 78 X 211	-3°C+35°C	230 +/-10%	50/60	4.14	18	<72	250	2
MATCTWTF	140 X 78 X 211	-3°C+35°C	230 +/-10%	50/60	4.14	18	<72	252	2
STGTWCOMB	140 X 78 X 211	+2°C+35°C -3°C+35°C	230 +/-10%	50/60	4.09	17.8	<72	253	2

CLIMATOUCH® SPECIFICATIONS

4.3

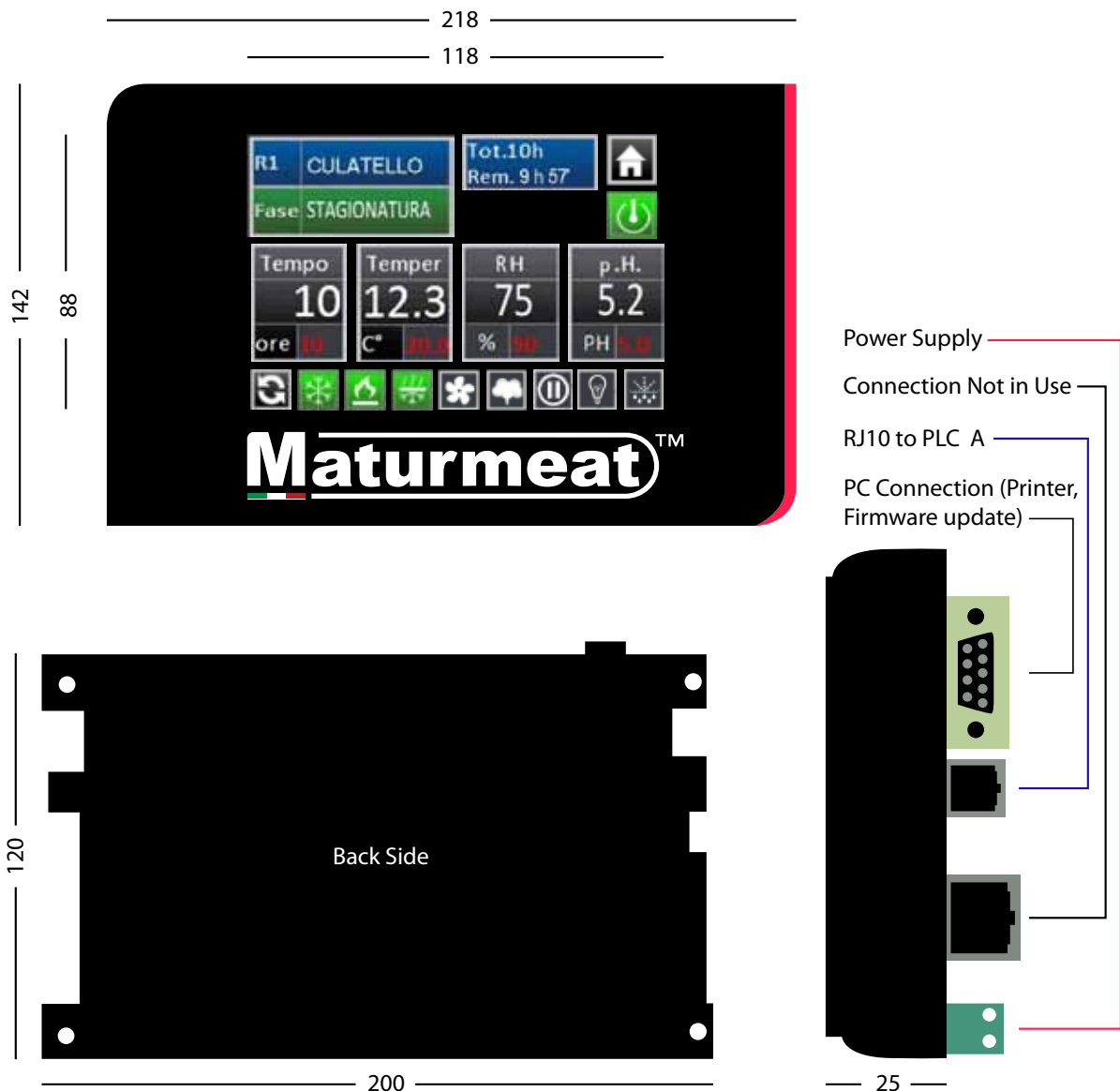

CLIMATOUCH® SPECIFICATIONS conituned

Power supply			
Voltage	230 V~ ± 10% 50Hz/60Hz		
Max. absorbed power (electronic control only)	10 V A		
Climatic conditions			
Working temperature	- 5.....+50°C		
Storage temperature	-10.....+70°C		
Ambient relative humidity	Less than 90% RH		
General Characteristics			
Type of connectable probes (temperature)	NTC 10K 1%		
Resolution (ambient temperature)	0.1°C		
Probe reading precision (ambient temperature)	± 0.1°C		
Reading range	-50.....+200°C		
Humidity probe	0-100% 4-20 mA		
Humidity probe reading precision	see characteristics of humidity probe		
Humidity probe reading range	0-99% RH		
Outlet characteristics			
Description	Installed relay	Card outlet characteristics	Notes
Cold (outlet 16-17)	(30 A-C1 Relay)	30A 240V - (AC3) (2HP) (100K cycles)	All the outlets are clean unpowered contacts.
7 outlets from 18 to 29 6 outlets from 18 to 29	(16 A-C1 Relay)	16A 250V - (AC1) (4KW) (10M cycles)	
Dimension characteristics			
MASTER dimensions	180 x 50 x 130 mm		
Climatouch® dimensions	118 x 30 x 89 mm		

4.4

FUNCTIONS MANAGED BY CLIMATOUCH®

- Display and regulation of set temperature, set humidity (neutral zone) and set PH (read only) parameters.
- Enable/disable stand-by status
- Probe alarm warnings
- Regulation of air cycle control parameters
- Regulation of defrosting parameters
- Regulation of rest period parameters
- Regulation of fan parameters
- Regulation of air exchange kit (Standard on models 150kg, 400kg, 800kg, 300kg and 600kg. Optional on models 60kg, 100kg, 200kg twin 100+100kg and Combo)
- Regulation and management of control parameters for the smoking/flavouring and/or humidification stages
- Display of the outlet status
- Simultaneous display of temperature, humidity and pH values
- Display and management of both, default climatic recipes and saved recipes created by you, with automatic variation of the times set for the individual stages and for temperature, humidity, smoking/flavoring, fan speed, rest periods and air cycle periods.
- Clock and date function

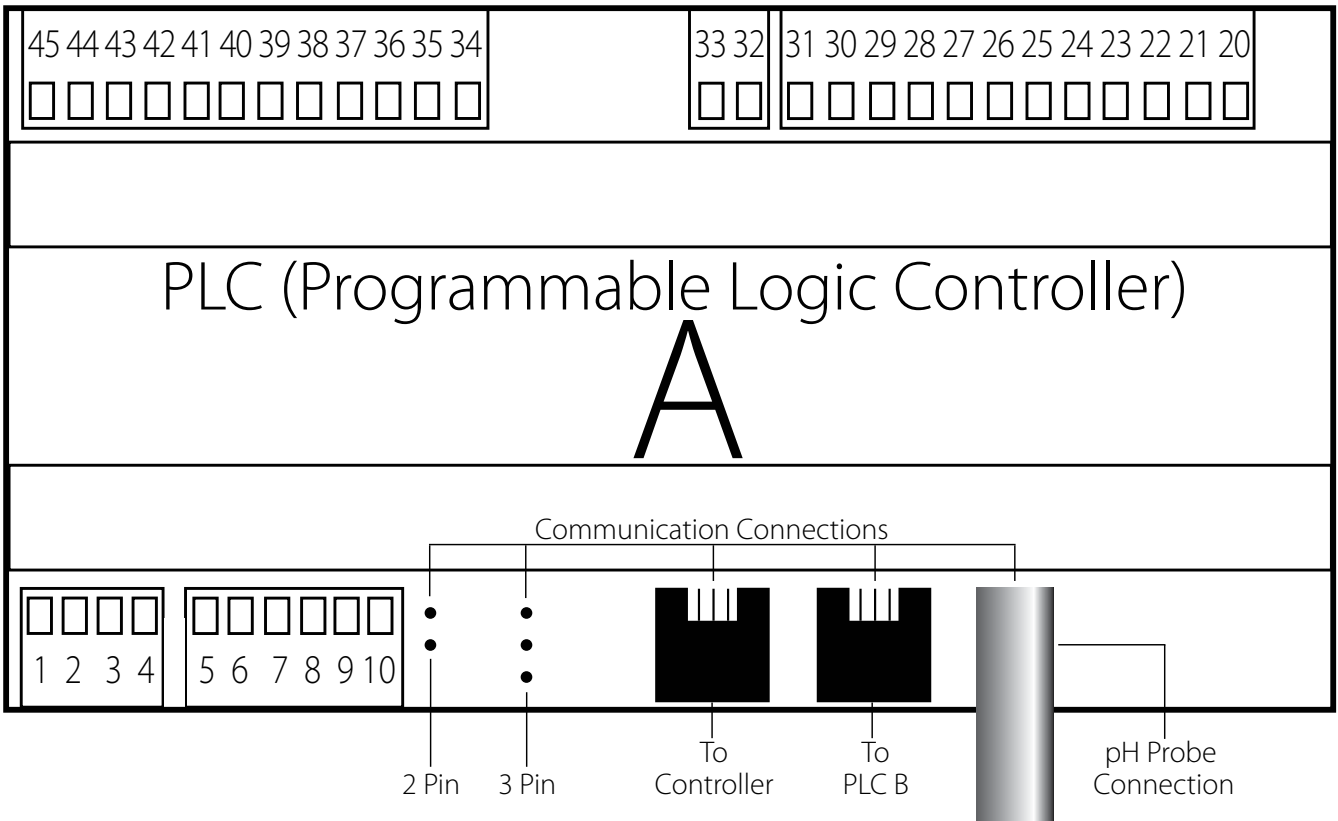

Power Supply Section	
1 & 2:	Power supply 24 V/AC/DC 50/60 Hz

Digital Input Section	
3 & 9:	Humidity probe 4.20 mA (0-100 Rh%)
7 & 8:	Evaporator probe
5 & 6:	Ambient probe
44 & 45:	Stand-by forcing
40 & 45:	Door Switch
43 & 45:	Force hot disable
42 & 34:	Force cold disable
41 & 45:	Force humidification disable
RJ10 Connection: RJ10 to RJ10 com cable to controller	
2 Pin: Cover both pins for com mode during firmware update	
3 Pin: DWL to USB cable for use during firmware update	

Digital Output Section	
32 & 33:	Compressor
20 & 21:	Heating
22 & 23:	Flavouring
24 & 25:	Humidification
26 & 27:	Dehumidification
28 & 29:	Rest Cycle
30 & 31:	Alarm
RJ10 Connection: RJ10 to RJ10 com cable to PLC B	

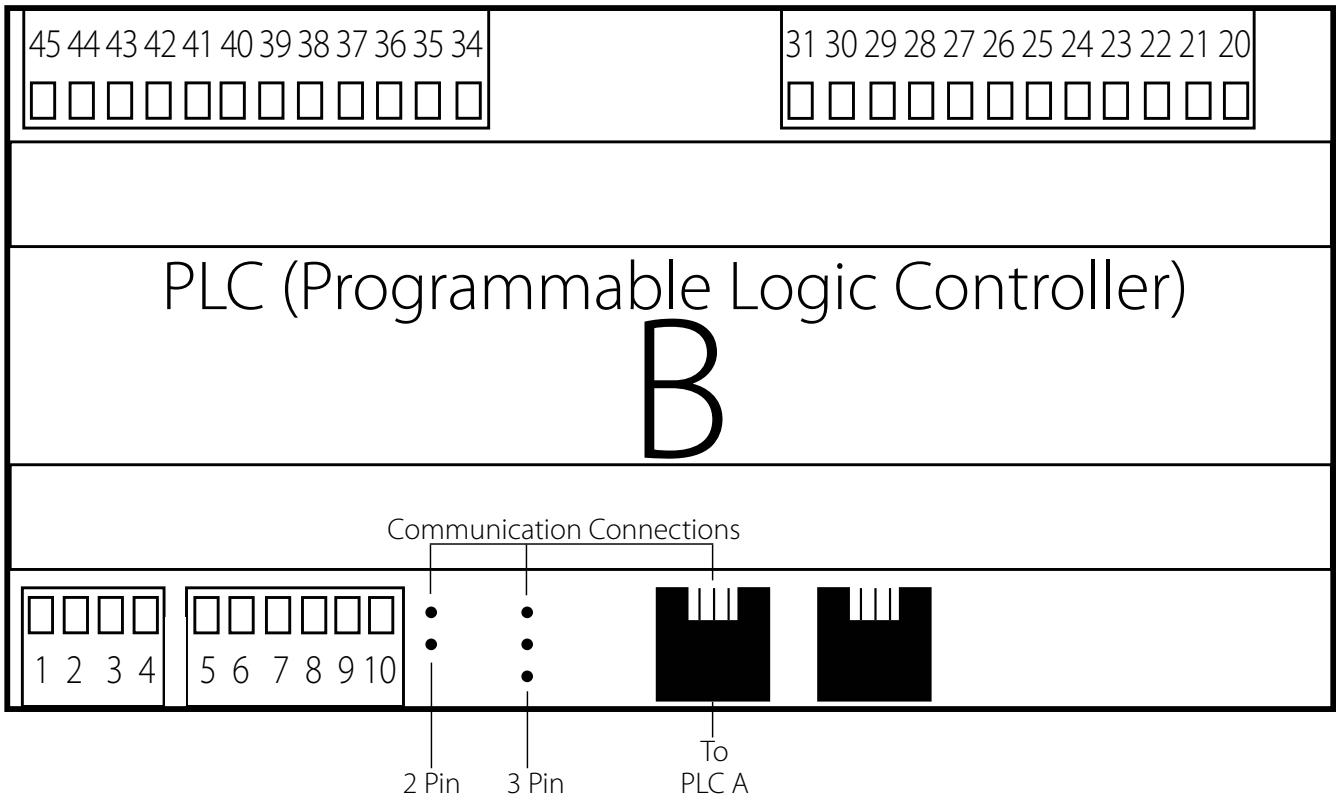

Power Supply Section

1 & 2: Power supply 24 V/AC/DC 50/60 Hz

Digital Input Section

5 & 6: NTC condenser probe
 44 & 45: Low H2O/flavouring level alarm
 43 & 45: Low Refrigerant level alarm
 42 & 45: High Freon pressure alarm
 41 & 45: Compressor thermal alarm
 40 & 45: Air exchange alarm
 RJ10 Connection: RJ10 to RJ10 com cable to PLC A
 2 Pin: Cover both pins for com mode during firmware update
 3 Pin: DWL to USB cable for use during firmware update

Digital Output Section

20 & 21: Defrost
 22 & 23: Low ventilation
 24 & 25: High ventilation
 26 & 27: Air exchange
 28 & 29: Light
 30 & 31: Condenser fan

ELECTRICAL SCHEMATIC 100kg

4.7

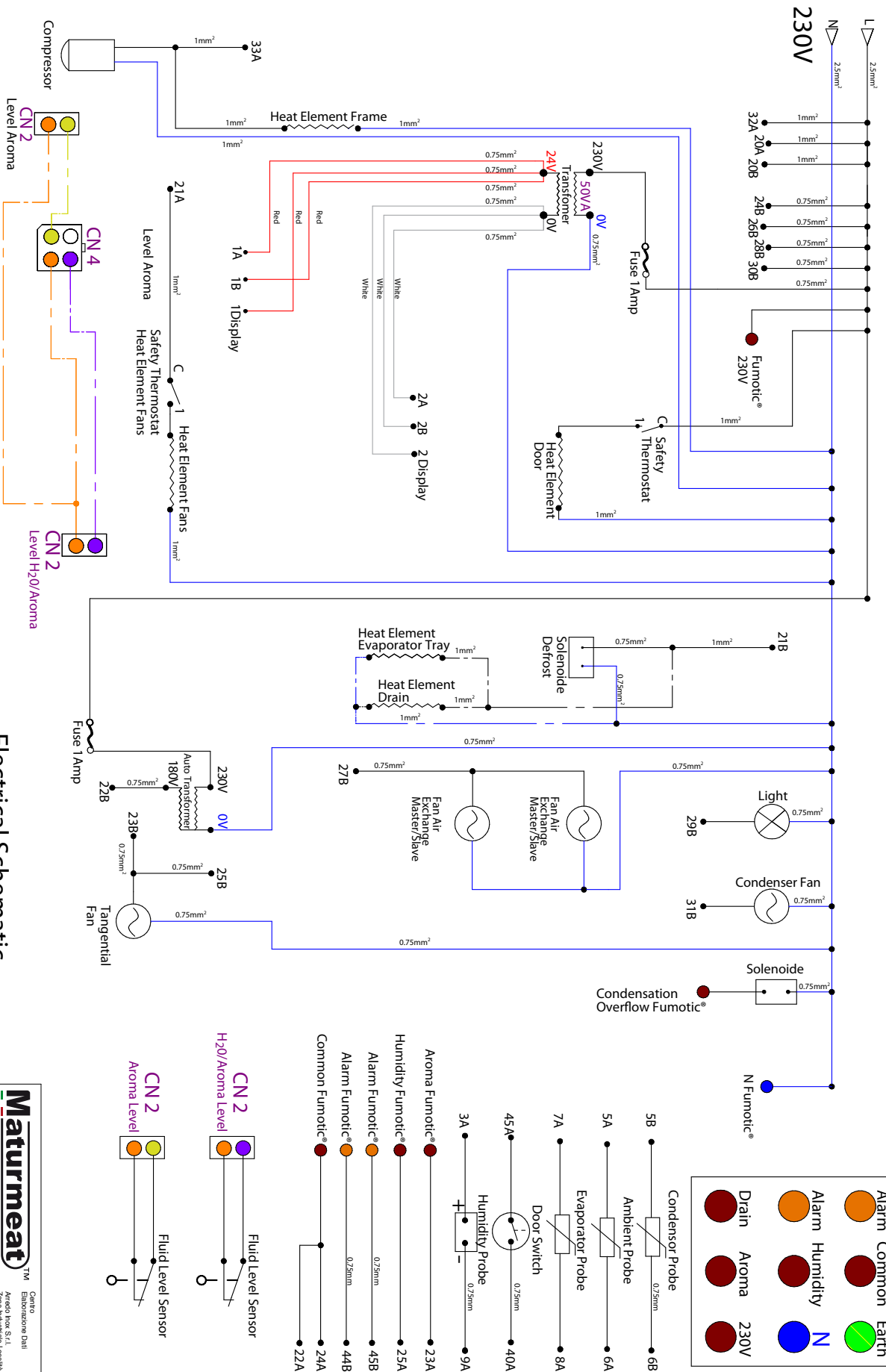

**Electrical Schematic
100kg Model**

Maturmeat		Centro Elaborazione Dati	
Modello	0000000000	Modello	0000000000
Versione	0000000000	Versione	0000000000
Stato	0000000000	Stato	0000000000
Descrizione	Zona Industriale Località Zgnri PI 00205/0000000000		
CARTAZZO TECNICO - I SERVIZI DI TRASMISSIONE ELETTRICA E DEI SISTEMI DI CONTROLLO			

ELECTRICAL SCHEMATIC 150kg

4.8

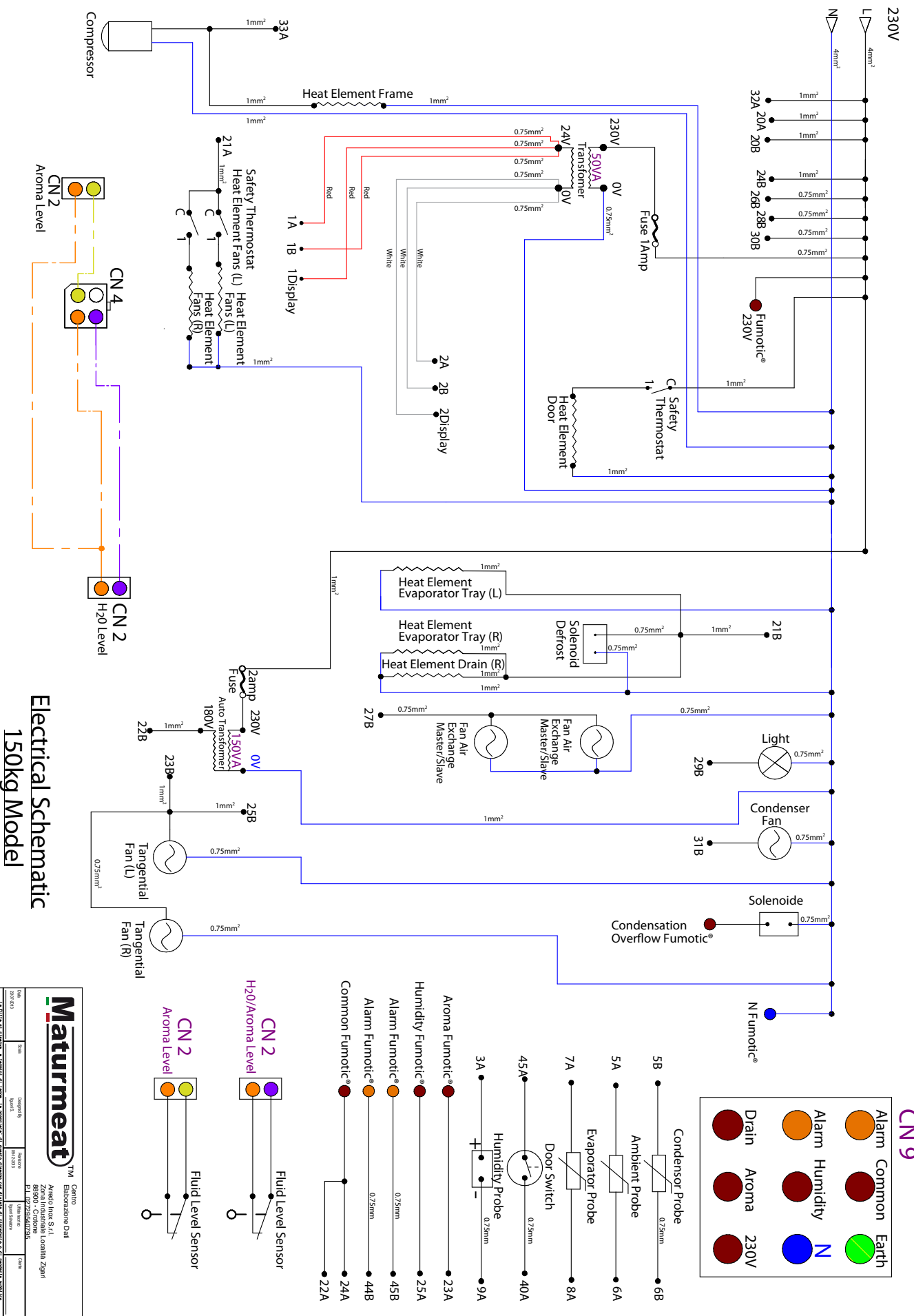

Electrical Schematic
150kg Model

Maturmeat TM Centro Ediliziazione Dati
Avenida Irina S. I. I.
50014, Santa Irina, Provincia de Santa Fe, Argentina
P. I. 40229540735

H20/Aroma Level
 Aroma Level
 Fluid Level Sensor
 Fluid Level Sensor

ELECTRICAL SCHEMATIC 200kg

4.9

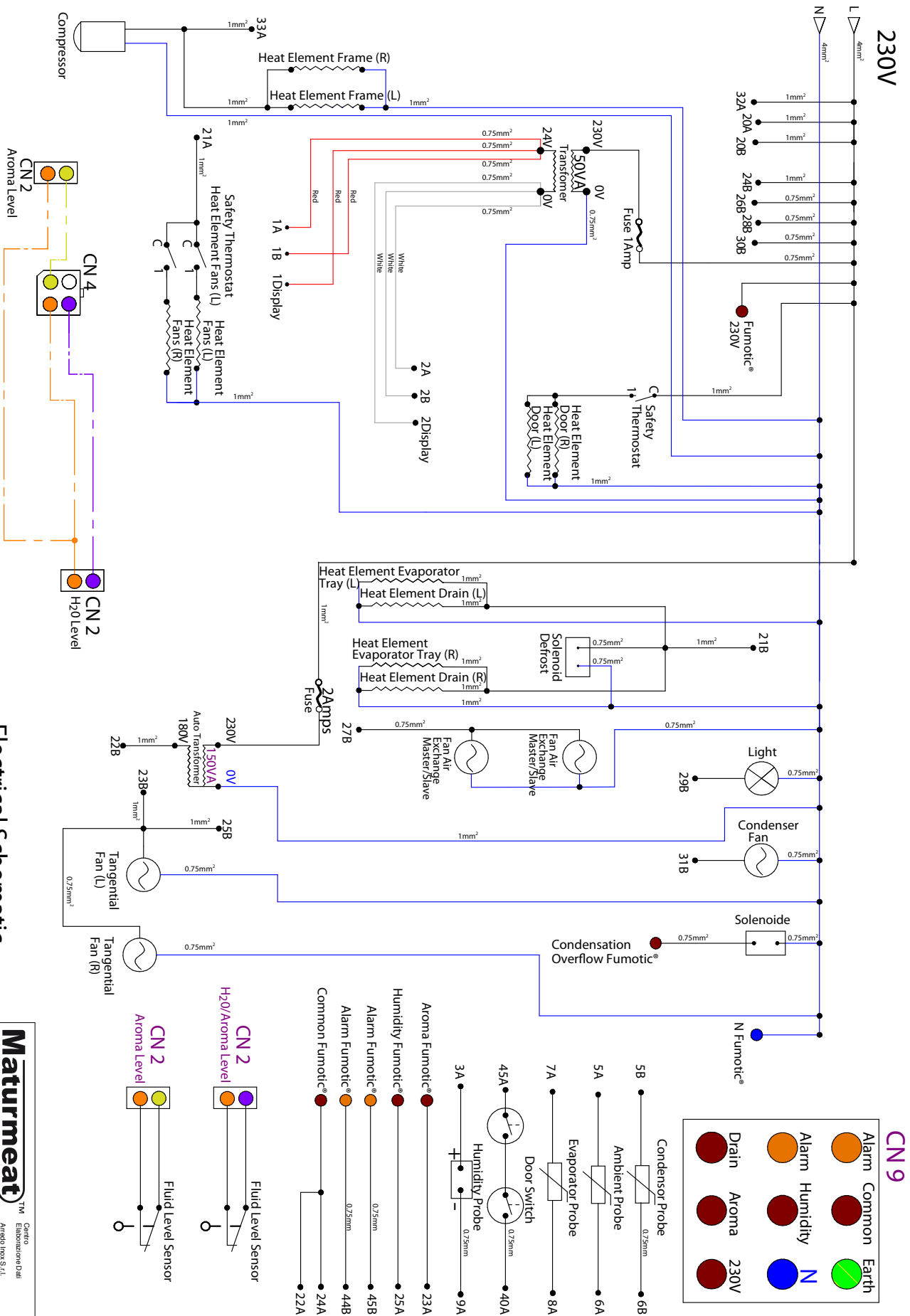

Electrical Schematic
200kg Model

Maturmeat™

Centro Elaborazione Dal
Asolo Iov, S. 11
Zona Industriale Località Zgnari
88800 - CROTONA
P.I. 01452000824

CE 017177 - Fumotic® e Fumotic® 150VA sono marchi registrati di Fumotic® e di Fumotic® Products.

Modello	200kg
Versione	1.0
Autore	...
Revisione	...
Stato	...
Descrizione	...
Autore	...
Revisione	...
Stato	...
Descrizione	...

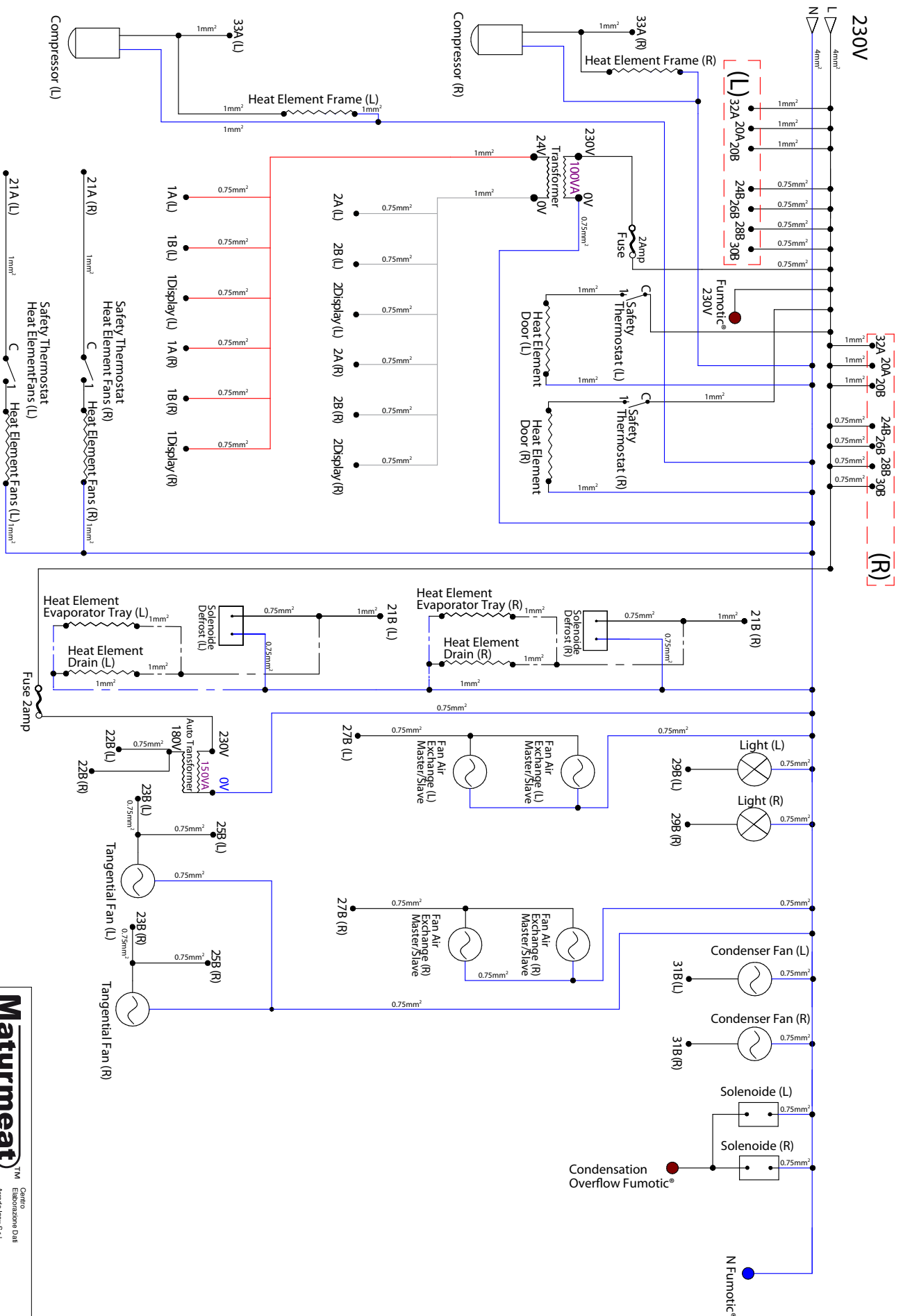

Electrical Schematic Table1
Twin 100+100kg Model

Maturmeat™

Centro Elaborazione Dati
Agnoli, box 5/1
Zona Industriale Località Zgari
88090 - Crotone
P.I. 045402508
Tel. 0965/860001
Fax 0965/860002

Modello	02070003
Versione	001
Completato	03/03/2011
Verificato	03/03/2011
Autore	03/03/2011
Stampato	03/03/2011

© 2011 Maturmeat. Tutti i diritti sono riservati. È vietata la ristampa o l'uso non autorizzato senza permesso scritto dalla Maturmeat.

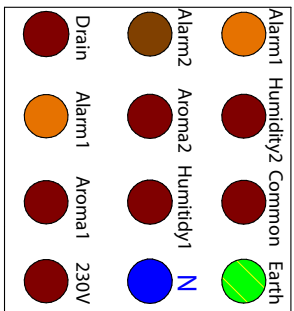
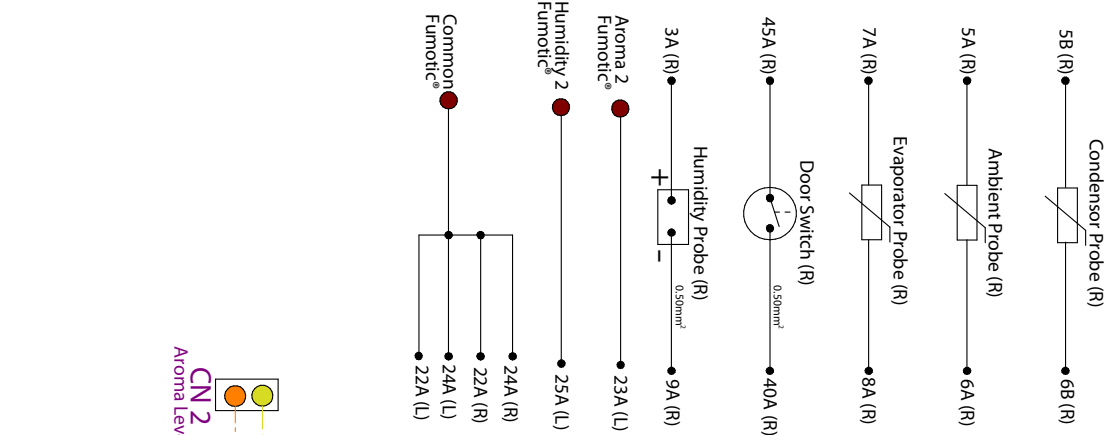
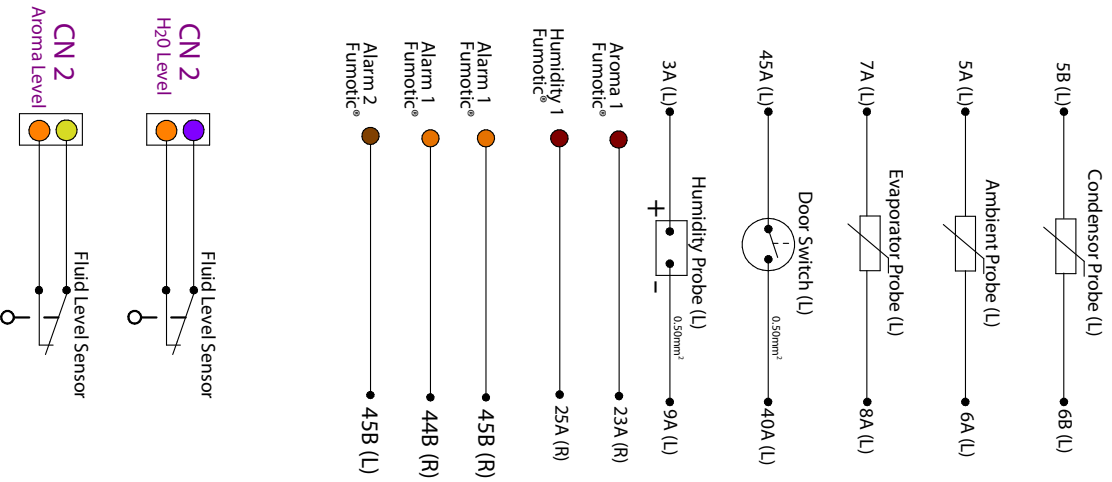

CN12

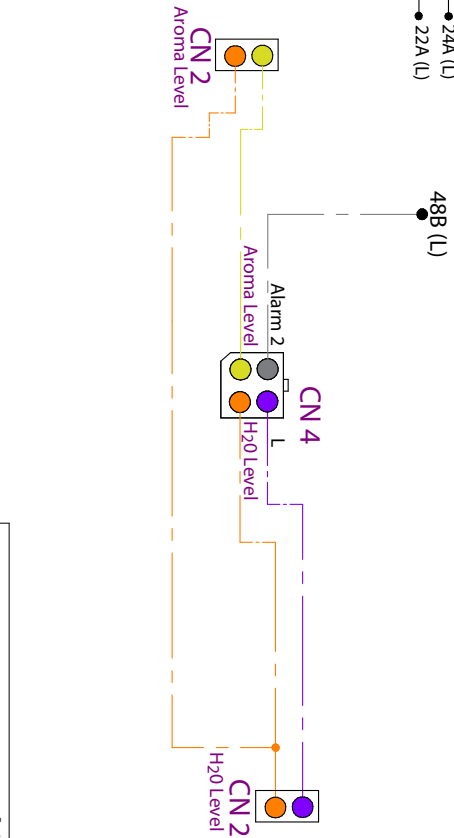

Electrical Schematic Table2
Twin 100+100kg Model

Maturmeat™
 Centro Elaborazione Dotti
 Azienda Inova S.r.l.
 Località Zguri
 88090 - Crotone
 P.I. 02729840786

Modello	Scale	Dimensioni	Materiali	Caratteristiche
000001				
LE 01718 91718918 91718918 91718918 91718918 91718918 91718918 91718918 91718918 91718918				

4.12

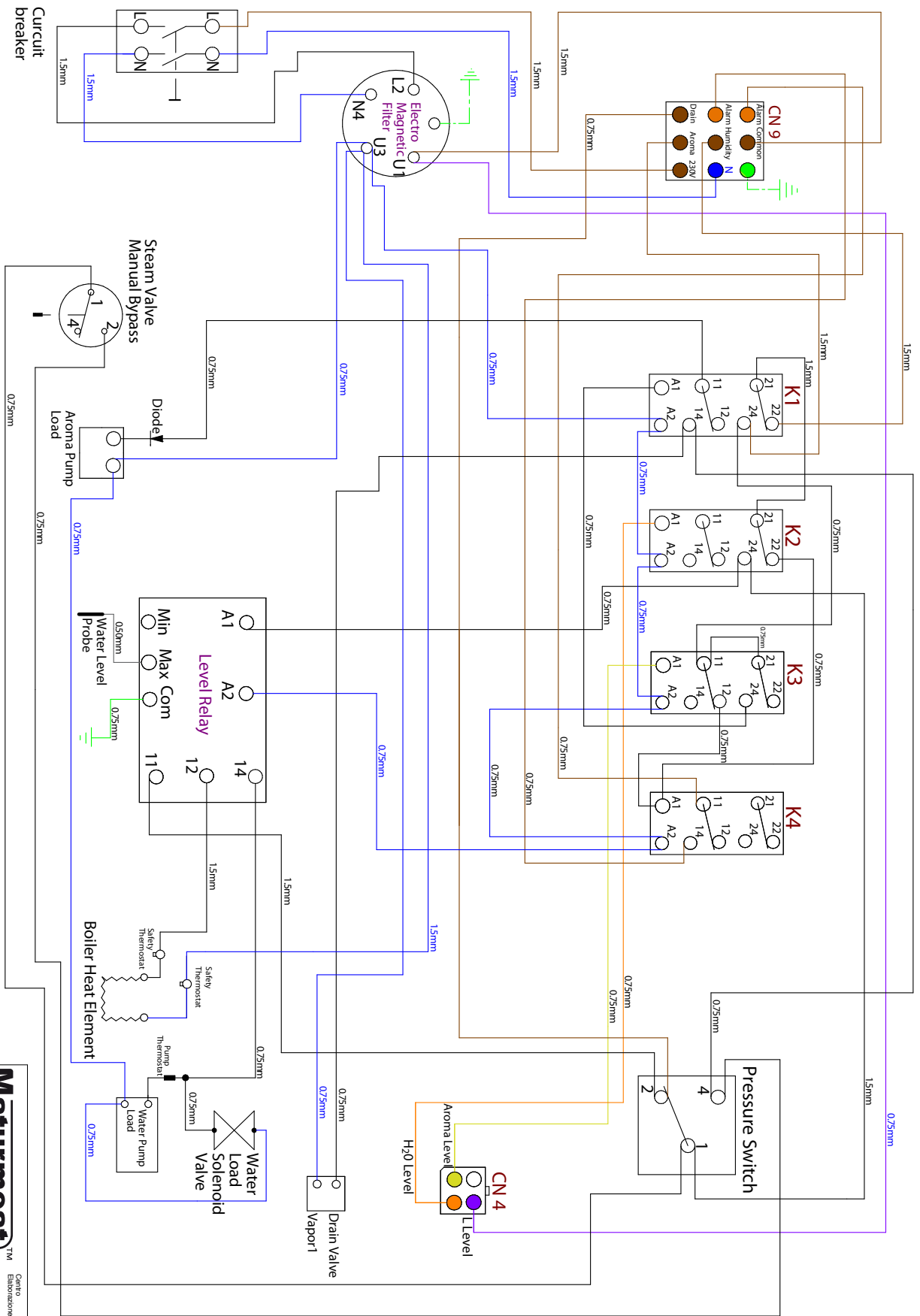

Fumotic® 60/100/150/200kg 9 + 4 Pin Connector

Maturmeat TM		Centro Elaborazione Dati	
Modello	0000000	Versione	0000000
Disegnato	0000000	Revisione	0000000
Autore	0000000	Approvato	0000000
Zona Industriale Località Zgani		P.I. 02726400724	
Via S. Francesco 1 - 00000 - Roma		Tel. 06 57500000	
Fax 06 57500001		E-mail: info@maturmeat.com	
www.maturmeat.com		SISTEMI DI POMPARE, SFRUGARE E TRONCARE IL PRODOTTO E IL PRODOTTO FINITO	

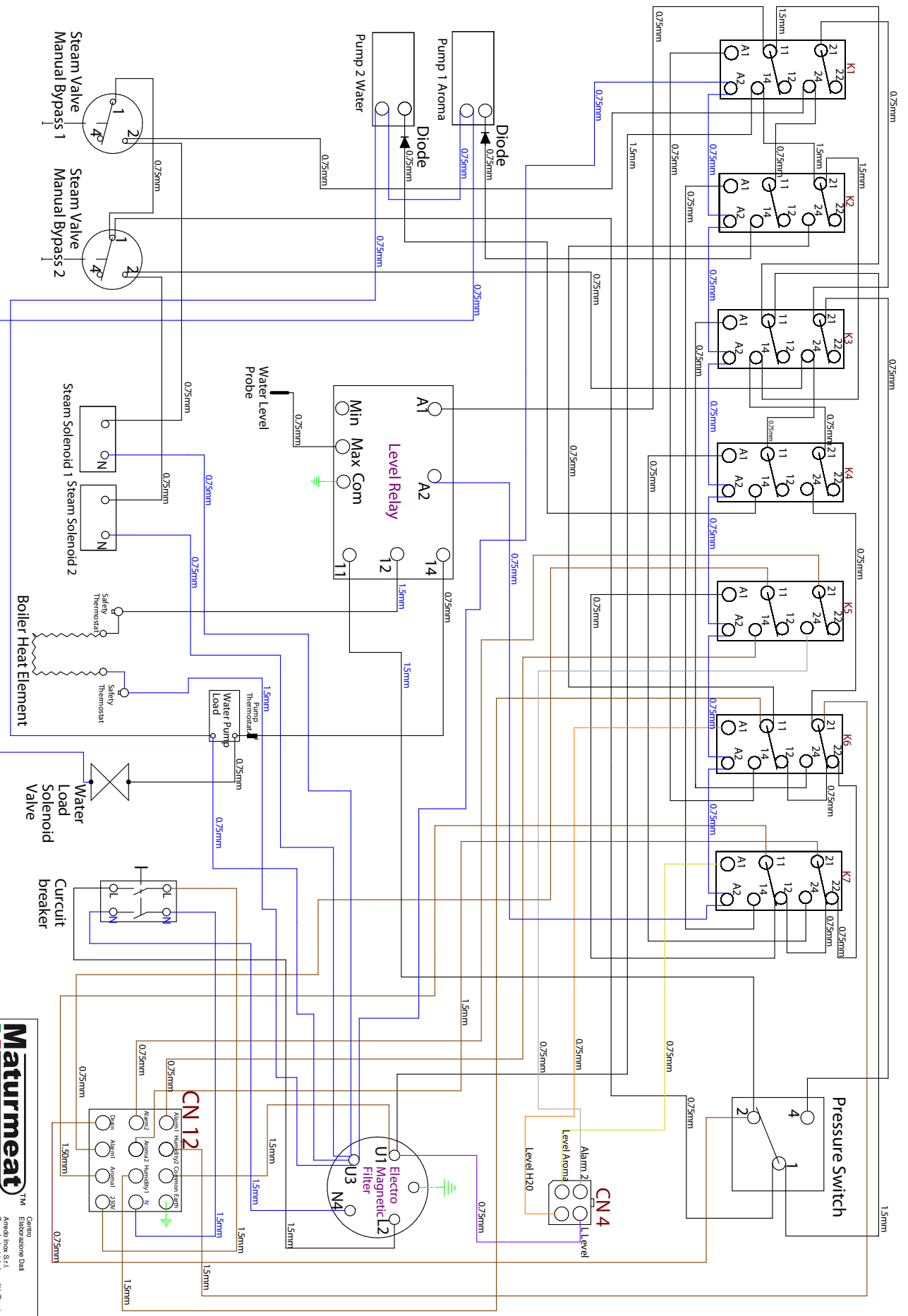

Fumotic® Twin 12 + 4 Pin Connector

Maturmeat ™		Centro Elaborazione Dati	
Via S. Maria di Tirolo, 4 - 38010 Tirolo (TN) - Italia		Ampio Ince, S.L.I.	
Tel. 0461/23000		88900 - Cologno	
Fax 0461/23001		P.O. Box 20000	
E-mail: info@maturmeat.it		Via S. Maria di Tirolo, 4 - 38010 Tirolo (TN) - Italia	
Web: www.maturmeat.it		Via S. Maria di Tirolo, 4 - 38010 Tirolo (TN) - Italia	

Arredo Inox Srl is the exclusive licensed manufacturer of the patents from Alessandro Cuomo Brevetti Milano

This limited warranty covers all standard plug-in cabinets and walk-in units up to 800kg maximum load. Arredo Inox Srl warrants its equipment to the original purchaser against defects in materials or workmanship for a period of one year from the date of installation. This limited warranty is not transferable. Warranties for parts and labor last one year. If service work is carried out under Limited Warranty, this will not extend the Limited Warranty period for the unit, or for the new parts. The warranty is voided by improper placement/storage, use, or when used in ambient temperatures exceeding 32°C / 89°F, please refer to user/instructional manual for further details. The warranty period begins on the date of installation, after validation through online registration at <http://www.stagionello.it/authentication.php?back=my-account.php> and applies only if the purchaser has not violated any of the exclusions or limitations listed below.

What is not covered under this Limited Warranty

- Normal wear and tear;
- Deliberate or negligent damage, damage caused by failure to observe operating instructions, incorrect installation or by connection to the wrong voltage, damage caused by chemical or electro-chemical reaction, rust, corrosion or water damage including but not limited to damage caused by excessive minerals in the water supply, damage caused by abnormal environmental conditions;
- Consumable parts, these include, but are not limited to: light bulbs, bulb enclosures, batteries, fuses, and gaskets;
- Non-functional and decorative parts, which do not affect normal use of the appliance, including any scratches and possible color differences;
- Any build up of scale/calcium a) in and/or around the lines leading into or exiting the Fumotic™, b) within the Fumotic™ itself;
- Accidental damage caused by foreign objects or substances and cleaning or unblocking of filters, drainage systems;
- Charges for service calls resulting in a diagnosis of equipment that was properly operating including, but not limited to: diagnosing equipment operation in a defrost mode, rest/recovery period, air cycling period, air exchange period, or power to the equipment was disconnected or interrupted, or that was shut down by over current or high/low pressure controls, or that the indicating temperature or humidity device was incorrectly calibrated;
- Failures caused by a) alteration/modifications or parts installed but not authorized by manufacturer, b) abuse and/or misuse of equipment, c) failure to provide adequate air flow around condenser and/or evaporator air coils, and/or d) failures caused by environmental effects and/or outside influences, including but not limited to fire damage, smoke damage, or explosions;
- Cleaning debris or removing ice from a heat transfer surface, not caused by a defect in materials and workmanship;
- The replacement of refrigerant without evidence of a leak in the system components;
- Adjustments of any operation control such as the thermostatic expansion valve, defrost components, pressure, oil safety, or temperature thermostat/controller;
- Repairs not carried out by our appointed service providers and/or an authorized service contractual partner or where non-original parts have been used;
- Repairs caused by installation, which is faulty or not according to specification;
- Transportation damages of any kind;
- Cost for carrying out the initial installation of the unit;

Due to the fact that Maturmeat™ uses programs that are modifiable by its operator, Arredo Inox srl accepts no responsibility for product loss, spoilage, unsafe/unhealthy or unsanitary products produced in the Maturmeat™. Please carefully read the instructional manual before attempting to install your unit to avoid injury and to ensure proper installation. Thoroughly inspect your unit after unpacking and report any damage during transit to your local area dealer, distributor, reseller, agent, etc. and transport company. All warranty claims must be made to the local area dealer, distributor, reseller, agent, etc. In the case where the unit is purchased directly from the manufacturer all warranty claims must be made to produzione@arredoinox.it. Any repair or replacement of a covered component may be made with a functionally equivalent component, as determined by Arredo Inox Srl.

Installed in the electronic control settings, default recipes and climatic variables of operation are to be considered indicative and otherwise be changed and / or user programmable in case of damage and / or failure of the food content in the machine as a result of execution the same, the manufacturer cannot be held responsible, civil and / or criminal and may not be charged at the same in anyway.

Humidity and Temperature Sensors/ Probes:

The probes in each Maturmeat™ used should be calibrated with a certified instrument and by trained personnel, all probes installed on the machines are very sensitive, it is recommended that they be calibrated each time a new production lot is started. Each unit is thoroughly tested before shipment, any inaccuracies or operating problems before and after the installation must be reported to the manufacturer within the first 8 days to ensure proper function, the manufacturer cannot be held liable in such case.

pH Probe Storage:

The probes should be stored in a protective capsule or in a container with their membranes immersed in a 3M KCl solution. The storage temperature should be between 10°/30°C, and never below -5°C. In case of loss of the protective capsule during transport or storage, the KCl could be removed easily by rinsing the probe in water. The probe will not suffer any consequences from this loss. The electrode must always be kept in its storage capsule filled with the corresponding electrolytic solution. The sensitive membrane should never be dry. If you do not have electrolyte solution, you can submerge the electrode in pH 4 buffer solution. Never store the electrode in distilled water.

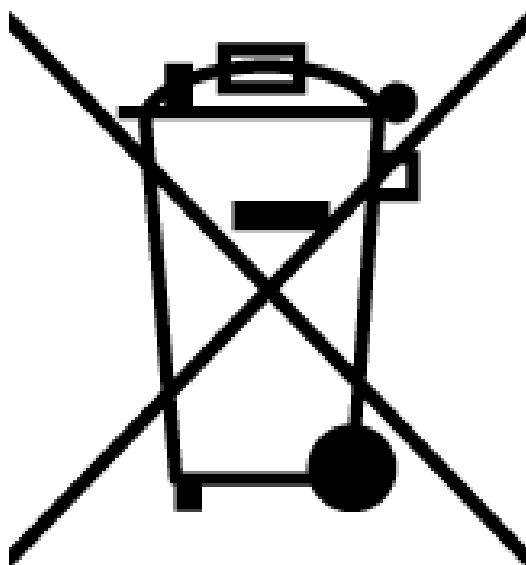

User's Information

Under Directives 2002/95/EC, Directive 2002/96/EC of the European Parliament and of the Council on the restriction of the use of certain hazardous substances in electrical and electronic equipment and DIRECTIVE 2003/108/EC amending Directive 2002/96/EC on waste electrical and electronic equipment.

Correct Disposal of This Product (Waste Electrical & Electronic Equipment)
 (Applicable in the European Union and other European countries with separate collection systems) This marking on the product, accessories or literature indicates that the product and its electronic accessories (e.g. charger, headset, USB cable) should not be disposed of with other household waste at the end of their working life. To prevent possible harm to the environment or human health from uncontrolled waste disposal, please separate these items from other types of waste and recycle them responsibly to promote the sustainable reuse of material resources. Household users should contact either the retailer where they purchased this product, or their local government office, for details of where and how they can take these items for environmentally safe recycling. Business users should contact their supplier and check the terms and conditions of the purchase contract. This product and its electronic accessories should not be mixed with other commercial wastes for disposal.

If outside of Europe, please refer to the Laws and bylaws specific to your Country, State, Province, Region, County, Municipality, etc., on how to properly dispose of this unit.

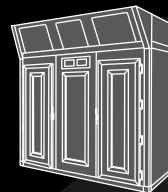
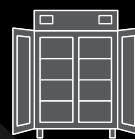
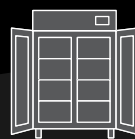
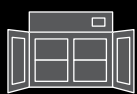

Via F. Mancuso Loc. Zigari (Z.I.) | IT | 88900 CROTONE (Kr)

Infoline: +39 0962 931654

www.stagionello.it

please contact the Stagionello™ **Point** in your area

