



Project _____
AIA # _____ SIS # _____
Item # _____ Quantity _____ C.S.I. Section 114000

CUH HIGH TEMPERATURE Undercounter



CUH HIGH TEMPERATURE

MODELS

- CUH** High temperature rinse

STANDARD FEATURES

- + 24 racks per hour
- + .84 gallons of water per rack
- + Hot water sanitizing
- + Top-mounted user interface with digital temperature display
- + 2-minute cycle with optional extended cycle
- + 14.46" door opening
- + Snap-in, revolving upper and lower anti-clogging wash & rinse arm; low-profile, single-arm design
- + Sense-a-Temp™ ensures 180°F final rinse
- + Integrated booster heater capable of 70°F rise
- + Removable, 3-part stainless steel scrap screen
- + Soft start
- + Automatic pumped drain
- + Automatic fill
- + Service diagnostics with error notifications
- + Delime notification and cycle
- + Chemical pumps standard
- + Electric tank heat
- + Two dishracks – one peg and one combination type
- + ENERGY STAR® certified



SPECIFIER STATEMENT

Specified unit will be NSF rated, ENERGY STAR® certified **Centerline by Hobart** high temperature undercounter dishwasher. Features soft start, two selectable cycles, one standard 2-minute cycle with optional extended cycle (factory set at 240 seconds); .84 gallons per rack, LED temperature and operator display, service diagnostics, detergent and rinse aid pumps. Constructed of stainless steel.

1 year parts and labor warranty.

STANDARD VOLTAGE

- + 208-240/60/1

OPTIONS & ACCESSORIES (Available at extra cost)

- Upper/lower stainless steel wash and rinse arm kit
- Chemical sensing indicators (low chemical alert)
- Stainless steel stand with rack storage and telescoping legs (legs in provide 15⁵/₁₆" of additional height; legs out provide 17⁷/₈" of additional height)
- Peg rack
- Combination rack
- Power cord kits
- DWT – Drain water tempering kit

Approved by _____ Date _____ Approved by _____ Date _____

LEGEND

Electrical Connections	
E1	Electrical connection: 1-3/8" dia. hole for 1" trade size conduit; 1-5/8" AFF.
E2	Electrical connection: Detergent, sanitizer and rinse aid; approximately 1-5/8" AFF.
E3	Electrical connection: (Optional) drain water tempering; approximately 3" AFF.
Plumbing Connections	
P1	Single fill and rinse connection: 3/4" female garden hose fitting on 6' long hose supplied with machine; 110°F water minimum for CUH approximately 1-13/16" AFF.
P2	Drain connection: 19mm O.D. barb fitting with 6' long hose supplied with machine.
P3	Chemical supply: Detergent and rinse aid; approximately 1-5/8" AFF. 63" long, 6mm O.D. tubing supplied with machine.

WARNING: Plumbing and electrical connections should be made by qualified personnel who will observe all the applicable plumbing, sanitary, safety codes and National Electrical Code.

(E1) STANDARD ELECTRICAL OPTIONS

Voltage	Rated Amps	Minimum Supply Circuit Ampacity	Maximum Protective Device
208/60/1	24.2	30	30
240/60/1	27.5	30	30

NOTE: For supply connections, use copper wire only rated at 90°C minimum.

Accessory cord kit available for all models.

Dishmachine not provided with internal GFCI protection.

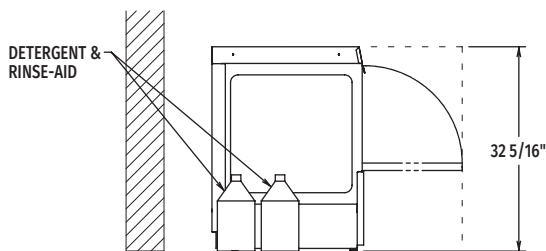

Left Side View

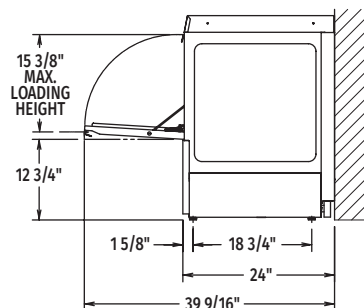

Right Side View

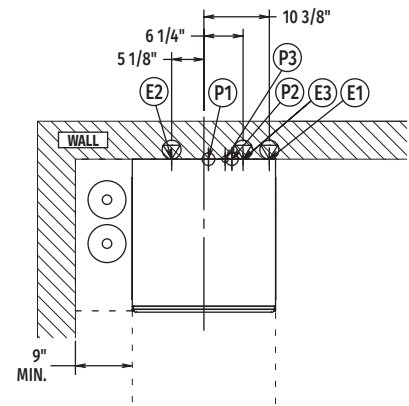

Top View

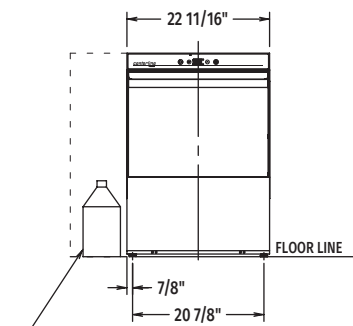

Front View

SPECIFICATIONS

Capacities

Cycle Time (seconds)	120
Racks per Hour	24
Tank Capacity – Gallons	5.3

Motor Horsepower

Wash	0.62
Rinse	0.20

Water Consumption

U.S. Gallons per Hour (maximum use)	20.2
U.S. Gallons per Rack (maximum use)	0.84
Peak Drain Flow – U.S. Gallons	2.8

Temperatures °F

Wash	150
Rinse	180
Incoming Water Temperature (minimum recommended)	110° F

Heating

Tank Heat, electric (kW)	5.5
Electric Booster (kW)	6.0

Standard 20" x 20" (508 x 508) Rack Complement

Flat	1
Peg	1

Shipping Weight (approximate) 148 lbs.

Crated Dimensions 27 3/4" W x 26 1/2" L x 38 3/4" H

Heat Output, BTU/Hour		
Volts	Latent	Sensible
208	4,300	1,800
240	5,600	2,400

MODEL:
CUH
00-562543
REV A