

PRODUCT:

QUANTITY:

Models HRDi-31S HRDi-50S HRSDi-31 HRSDi-50
ITEM:

Save Time & Money Today!

The New Digital Roller Grill utilizes the latest control technology to improve performance. It will improve your overall operations by minimizing waste and reducing labor all while adhering to HACCP food safety standards.

Designed Smart

Equipment Packages to fit your Operations!

- Available in a variety of sizes to fit your counter space:
- Compact HR(S)-20S (11 rollers & 13" cooking surface across)
- Regular size HR(S)-31S (11 rollers & 19 ½" cooking surface across)
- Full Menu Size HR(S)-50S (11 rollers & 30 ½" cooking surface across)
- Available in Chrome or "Tru-Turn" textured rollers.

Designed to Deliver Great Tasting Hot Dogs!

- Roller Grill heats quickly and has a fast recovery.
- Heating system has two zones that can be turned to Grilling temperatures for cooking or turned down to NSF-safe holding temperatures for serving customers.
- Digitally controlled elements provide uniform temperature distribution and longer product life than conventional roller grills.

Easy to Operate and Maintain!

- Simple operation: place product on grill, push a button and walk away. Digital control will automatically cycle through Preheat, Cook and Hold modes.
- Easy to read, bright LED's signal operator when product is ready to serve.
- Large digital display shows estimated temperature of product while roller grill is in hold mode.
- Designed to require minimal labor:
 - "Tru-Turn" coated rollers just wipe clean with damp rag.
 - Raised rollers allow cleaning in hard to reach areas.
 - Removable grease collection pan is simple to clean.
- Easiest Roller Grill in the industry to service:
 - Unit is supplied with easy to remove side and bottom panels.
 - Dependable, high torque motor is one of the most dependable in the industry

Design Features

- Exterior cabinet constructed of stainless steel for maximum durability
- "Tru-Turn" coating is 30% thicker than competitive non-stick coatings.
- Teflon Seals at end of rollers stop grease from migrating into motors and chains.



X*PERT™ Series

- US Patent 8,727,625 Bearing Design – Bearing is larger, has more surface contact area. Provides more roller tube support. Eliminates wear, wobble and more than doubles overall bearing life, thus providing more years of dependable service.
- US Patent 8,581,154 Electronic Controls
- Tru-Turn roller system enhancements include improved metal gear sprockets, design improvements on the Self Aligning Chain Guide System to provide noise free and smooth chain operation along with eliminating chain slippage.
- Tru-Turn roller tube coating processes have been enhanced to provide the thickest coating in the industry (measured by mil thickness and over 30% greater than competitor units) which provide years of better turning of products, ease of cleaning and a better looking roller grill.
- Tru-Heat has been enhanced to provide more even heating across the roller grill surface and maintain a temperature variance of less than 7 degrees. Tru-Heat eliminates hot spots found in competitor roller grills which over-heat products and greatly reduce product hold time, causing increased waste.

Reliability Backed by APW Wyott's Warranty

All APW Wyott Roller Grills are backed by a 1 year parts and labor warranty, including on-site service calls within 50 miles of authorized service technicians.

Certified by the following agencies:



PRODUCT:

QUANTITY:

Models HRDi-31S HRDi-50S HRSDi-31 HRSDi-50
ITEM:

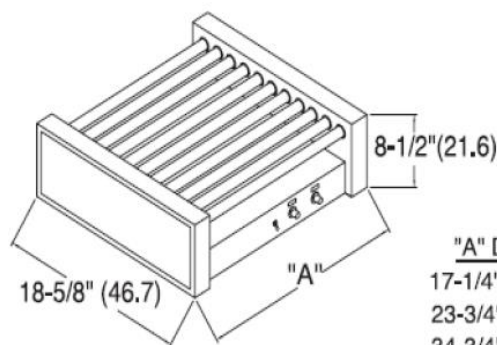
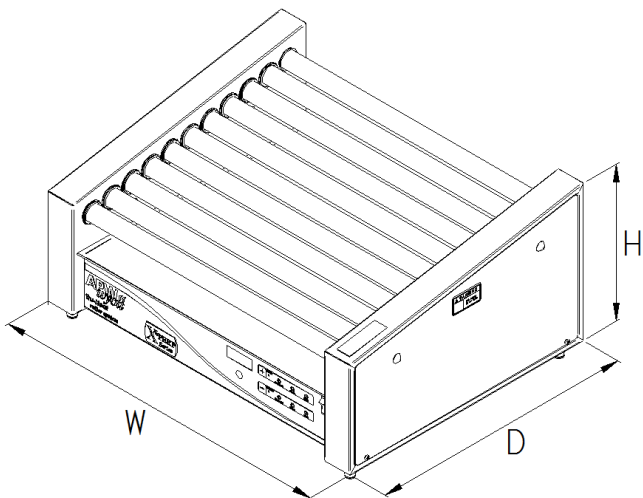

"A" DIMENSION
 17-1/4" (43.8) HR(S)-20
 23-3/4" (60.3) HR(S)-31
 34-3/4" (88.3) HR(S)-50
 6 FT. CORD (182.9)
 (CENTIMETERS IN PARENTHESIS)

Accessories & Options:

- 4" Metal Leg Kit
- Pass through Sneeze Guards
- 6" Tong
- Divider Kits
- Polycarbonate Sneeze Guards
- S = TruTurn coating on roller tubes
- BW = Bun Warmer, heated bun drawer
- BD = Unheated Bun drawer
- R = Reverse controls on back of unit
- W = Wide spacing for bigger products

Construction:

Stainless steel exterior, aluminum drip pan and coated steel bottom. Chrome or "Tru-Turn" textured rollers (specify Model HRS-20S, -31S or 50S for "Tru-Turn". Heavy duty high torque motor.

Electrical Information:

120V units use a 5-15P plug. Both the 208V and 240V units are provided with a 60" power cord a NEMA 6-15P plug that exits from the bottom rear of the unit.

	Volts	Wattage	Amps	
HRSDi-31S:	120V	984W	8.2 A	60Hz
	208/240V	1172/1560W	5.6/6.5 A	60Hz
HRSDi-50S:	120V	1424W	11.9 A	60Hz
	208/240V	1270/1691W	6.1/7.1 A	60Hz
HRDi-31S:	120	984W	8.2 A	60Hz
	208/240V	1172/1560W	5.6/6.5 A	60Hz
HRDi-50S:	120V	1424W	11.9 A	60Hz
	208/240V	1270/1691W	6.1/7.1 A	60Hz

Overall Dimensions:

	Height	Width	Depth
HRSDi-31S:	11-3/4"	23-3/4"	18-5/8"
HRSDi-50S:	11-3/4"	34-3/4"	18-5/8"
HRDi-31S:	8-1/2"	23-3/4"	18-5/8"
HRDi-50S:	8-1/2"	34-3/4"	18-5/8"

Shipping Weight:

HRSDi-31S:	44 lbs (19.1 kg)
HRSDi-50S:	55 lbs (25 kg)
HRDi-31S:	44 lbs (19.1 kg)
HRDi-50S:	55 lbs (25 kg)

FOB: Allen, TX 75013

*APW Wyott reserves the right to modify specifications or discontinue models without incurring obligation.