



# XACC-0513-EPRM

Project \_\_\_\_\_

Item \_\_\_\_\_

Quantity \_\_\_\_\_

Date \_\_\_\_\_

Model  
**CHEFTOP MIND.Maps™ PLUS  
 COMPACT**

- Combi steamer
- Electric
- 5 trays GN 1/1
- Hinge on the left side (Right Hand Door)
- 9.5" Touch control panel



## DESCRIPTION

Technologically advanced combi oven for gastronomy cooking processes (dehydrating, steaming, low temperature cooking, sous vide cooking, roasting, grilling, pan frying, regeneration and plate regeneration) and for fresh or frozen baking thanks to Unox Intensive Cooking and Intelligence Performance technologies which guarantee perfect results and repeatability for any load size. Automatic management of cooking processes (CHEFUNOX) for perfect results even without trained staff.

## STANDARD COOKING FEATURES

### Programs

- 1000+ Programs
- **CHEFUNOX**: choose something to cook from the library and the oven will automatically set all the parameters
- **MULTI.TIME**: manages up to 10 cooking processes at the same time
- **MISE.EN.PLACE**: synchronises the insertion of pans so that all the dishes are ready at the same time
- **MIND.Maps™**: draw the cooking processes directly on the display
- **READY.COOK**: ready to use settings with infinite time for a quick start

### Manual cooking

- **Temperature**: 86 °F – 500 °F
- Up to 9 cooking steps
- **CLIMA.Control**: humidity or dry air set by 10%
- Delta T cooking with core probe
- SOUS-VIDE cooking
- 4-speed fan system

## STANDARD TECHNICAL FEATURES

- **ROTOR.Klean™**: automatic washing system
- Automatic special washing behind the fan guard
- Cooking chamber in high-resistance AISI 304 stainless steel with rounded edges
- Triple glass
- Cooking chamber lighting through LED lights embedded in the door
- Tray supports with anti-tip system
- Drip collection system integrated in the door which works even when the door is open
- 4-speed fan system and high-performance heating elements
- Integrated DET&Rinse™ detergent container
- Integrated Wi-Fi
- **Wi-Fi / USB data**: download/upload HACCP data
- **Wi-Fi / USB data**: download/upload programs
- Fully integrated drain cooling valve (drain discharge temp. ≤ 140°F)

## ADVANCED AND AUTOMATIC COOKING FEATURES

### Data Driven Cooking

- Control and monitor the operating conditions of your ovens in real-time, create and share new recipes. The AI transforms the consumption data into useful information in order to increase your daily profit. Create, understand, improve

### Unox Intelligent Performance

- **ADAPTIVE.Cooking™**: automatically regulates the cooking parameters to ensure repeatable results
- **CLIMALUX™**: total control of the humidity in the cooking chamber
- **SMART.Preheating**: automatically sets the preheating temperature and duration
- **AUTO.Soft**: manages the heat rise to make it more delicate
- **SENSE.Klean**: estimates how dirty the oven is and suggests the appropriate automatic washing cycle

### Unox Intensive Cooking

- **DRY.Maxi™**: rapidly extracts the humidity from the cooking chamber
- **STEAM.Maxi™**: produces saturated steam
- **AIR.Maxi™**: manage fans auto-reverse and pulse function
- **PRESSURE.Steam**: increases the steam saturation and temperature

## APP & WEB SERVICES

- Data Driven Cooking app & webapp
- Top Training app
- Combi guru app



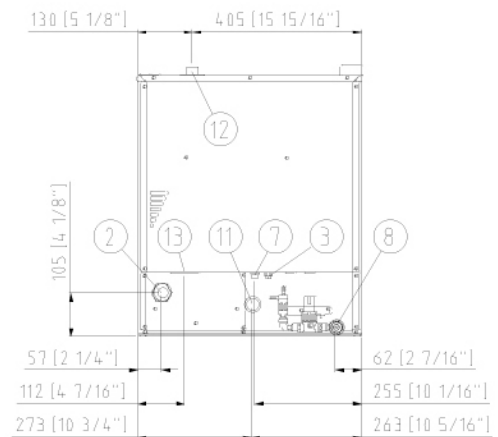
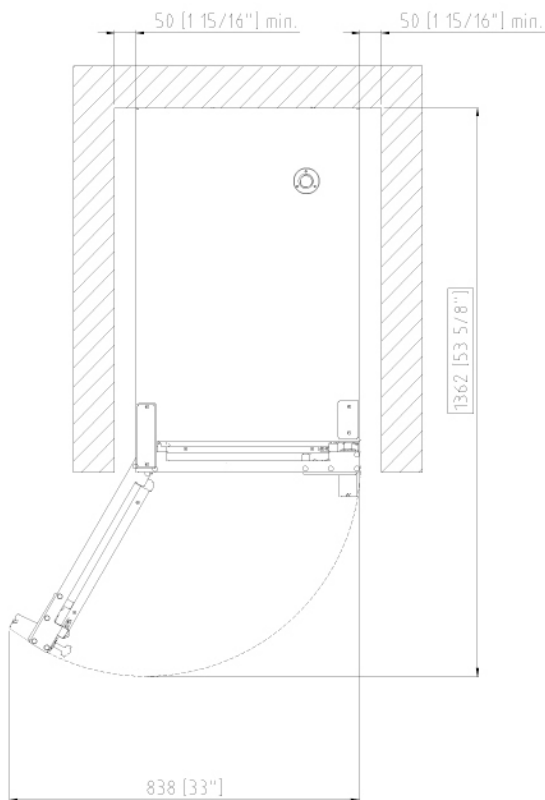
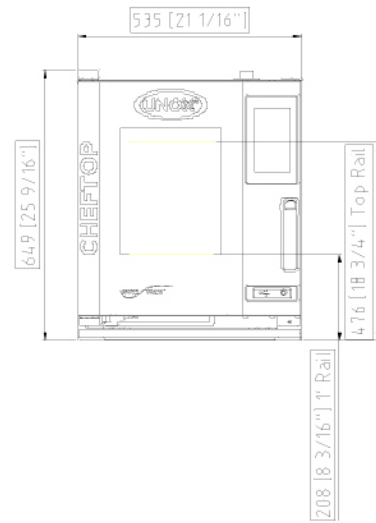
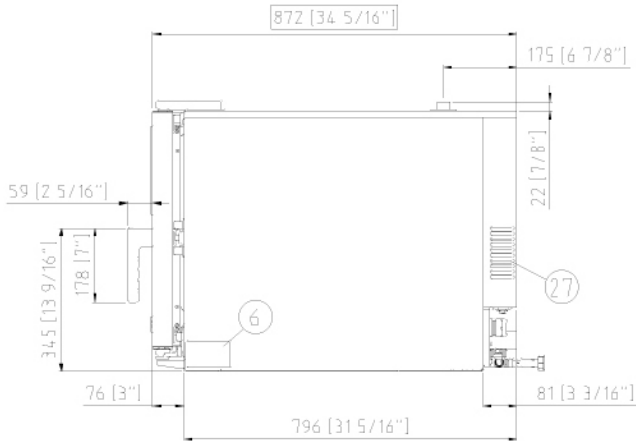

## DIMENSIONS AND WEIGHT

Width	21-1/16"	535 mm
Depth	34-5/16"	872 mm
Height	25-9/16"	649 mm
Net Weight	150 lbs	68 kg
Tray pitch	2-5/8"	67 mm

## CONNECTION POSITIONS

2	Power cord	11	Chamber drain pipe
3	Unipotential terminal	12	Hot fumes exhaust chimney
6	Technical data plate	13	Accessories connection
7	Safety thermostat	27	Cooling air outlet
8	3/4" female NPT water inlet		



# XACC-0513-EPRM

Power and gas supply  
 Water connections  
 Installation requirements  
 Accessories

## POWER SUPPLY

### STANDARD

Voltage	240 V
Phase	~3PH+PE
Frequency	60 Hz
Total power	7.7 kW
Maximum Amp Draw	19.5 A
Required breaker size	25 A
Power cable requirements*	4 x AWG 10
Cord size*	0.63 in
Plug	NOT INCLUDED

### OPTION B

Voltage	240 V
Phase	~1PH+PE
Frequency	60 Hz
Total power	7.7 kW
Maximum Amp Draw	32.5 A
Required breaker size	40 A
Power cable requirements*	3 x AWG 8
Cord size*	0.63 in
Plug	NOT INCLUDED

### OPTION A

Voltage	208 V
Phase	~3PH+PE
Frequency	60 Hz
Total power	5.8 kW
Maximum Amp Draw	17 A
Required breaker size	25 A
Power cable requirements*	4 x AWG 10
Cord size*	0.63 in
Plug	NOT INCLUDED

### OPTION C

Voltage	208 V
Phase	~1PH+PE
Frequency	60 Hz
Total power	5.8 kW
Maximum Amp Draw	28.5 A
Required breaker size	35 A
Power cable requirements*	3 x AWG 8
Cord size*	0.63 in
Plug	NOT INCLUDED

\*Recommended size - observe local ordinance. Cable not included.



# XACC-0513-EPRM

Power and gas supply  
 Water connections  
 Installation requirements  
 Accessories

## WATER SUPPLY

USING A WATER SUPPLY THAT DOES NOT MEET UNOX'S MINIMUM WATER QUALITY STANDARDS WILL VOID ANY WARRANTY.

It is the responsibility of the purchaser to ensure that the incoming water supply is compliant with the listed specifications through adequate treatment measures.

**Line pressure:** Drinking water inlet: 3/4" NPT\*, line pressure: 22 to 87 psi; 1.5 to 6 Bar (29 psi; 2 Bar recommended)

### Inflow water specifications

Free chlorine	≤ 0.5 ppm
Chloramine	≤ 0.1 ppm
pH	7 - 8.5
Electrical conductivity	≤ 1000 µS/cm
Total hardness	≤ 30 °dH

### Steam circuit: inflow water specifications

Total hardness	≤ 8 °dH*
Chlorides	≤ 25 ppm

\*this value refers to daily steam cooking of 1- 2 hours. In any case, if with a total hardness ≤ 8°dH there is still production of limescale, it is mandatory to treat the water in order to avoid limescale production. We recommend water treatment systems based on ion exchange resins. Water treatment systems based on polyphosphates are not allowed.

## ACCESSORIES

- **Ventless hood:** steam condensing hood
- **SMART.Drain:** its functioning is based on a special two-way valve that collects any fat and cooking liquids created during the cooking program and drains them into a tank
- **LIEVOX:** Proofer equipped with sensors capable to control and intervene automatically on the leavening process
- **Neutral cabinet:** recommended solution to optimize your kitchen layout and always have everything in the right place
- **Stand:** the multifunctional support ideal for storing trays safely and placing your oven at the perfect height to work
- **Cooking Essentials:** special trays
- **DET&Rinse™ PLUS:** cleaning and rinse agents to combine maximum cleanliness with minimum consumption and long life for your oven
- **DET&Rinse™ ECO:** eco formula for daily cleaning and the utmost respect for the environment. Ideal for mild level of dirt.
- **FINEST:** resin-based filtering system that eliminates from the water all substances that contribute to the formation of limescale inside the oven cooking chamber
- **SOUS-VIDE:** Core probe
- Ethernet connection kit

## INSTALLATION REQUIREMENTS

Installations must comply with all local electrical systems, particularly as for minimum wire gauge required for field connection, hydraulic and ventilation supply. Exhaust and fume analysis must be performed in case of gas ovens.

Register to access data and product specifications  
[infonet.unox.com](http://infonet.unox.com)

