



WS-FD-8645-RFG-LR-IR configuration shown.

Job Name	
Model	WS-FD-8645
Item#	

The Fire Deck 8645 oven features a door opening 56 inches wide x 10 inches high, complemented by a glass heat shield and stainless steel mantle. The cooking area is 68 inches wide x 32 inches deep, resulting in a 15-square-foot cooking surface. A tensioned steel exoskeleton surrounding the hearth and dome perimeter ensures structural integrity and longevity. Wrapped in spun ceramic fiber insulation and requiring only a 1-inch side clearance to combustibles, the monolithic 4-inch thick cast-ceramic hearth and monolithic 4-inch thick dome rest on a black painted steel stand. The oven body front is finished with stainless steel; galvanized steel is used for the top, back and sides. The oven arrives completely assembled, ETL Listed, ready to install and is made in the USA. A set of optional rigging casters is available to aid in the initial installation. Information about custom finishes, tools and accessories can be found at: [woodstone-corp.com](http://woodstone-corp.com).

### HEARTH CAPACITY

8" pizzas:	20
10" pizzas:	14
12" pizzas:	10
16" pizzas:	5-6

Assuming 5-minute cook times, the approximate maximum hourly production capacity can be calculated by multiplying the above numbers by 12. Cook times will also vary depending on "style" of pizza. **Note:** The addition of an optional decorative flame will decrease space and impact overall cooking capacity.

### FUEL CONFIGURATIONS

**GAS-FIRED ONLY:** Configured to burn either natural gas (NG) or liquid propane (LP).\*

**RADIANT FLAME + UNDERFLOOR IR (RFG-IR):**

Heated by an easily adjustable radiant flame located on both sides of the cooking chamber, along with a thermostatically controlled infrared burner which is mounted under the oven deck to ensure high production capacity.

**DECORATIVE FLAME (-DF):** Provides an additional 15,000 BTU/hr flame at rear of cooking chamber for show.

**Note:** Option will reduce available hearth capacity.

**WOOD-FIRED (W):** Wood-fired only.

**WOOD WITH GAS ASSIST (W-IR):** This wood-fired model is assisted by the additional BTUs of an Underfloor IR burner. **Note:** A wood fire is required with this configuration.

**COMBINATION (-W):** Allows optional wood burning for ovens with gas burner configurations.\* **Note:** Adding wood to an oven with an RFG burner will reduce available hearth capacity.

\*Gas type must be specified at time of order.

### GUIDE TO MODEL NUMBERS

	Underfloor IR Burner	Left Side Radiant Flame	Right Side Radiant Flame	Decorative Flame (-DF)	Wood Required	Combination	Natural Gas	Liquid Propane
WS-FD-8645-RFG-LR-IR	X	X	X	-DF			-NG	-LP
WS-FD-8645-RFG-L-IR-W	X	X			X	X	-NG	-LP
WS-FD-8645-RFG-R-IR-W	X		X		X	X	-NG	-LP
WS-FD-8645-W-IR	X				X		-NG	-LP
WS-FD-8645-W					X			



t. 360.650.1111  
tf. 800.988.8103  
f. 360.650.1166

Wood Stone Corporation  
1801 W. Bakerview Rd.  
Bellingham, WA 98226 USA  
[info@woodstone-corp.com](mailto:info@woodstone-corp.com)  
[woodstone-corp.com](http://woodstone-corp.com)

REVISED: SPRING 2017

An ongoing program of product improvement may require us to change specifications without notice.



# FIRE DECK 8645

STONE HEARTH OVEN • WS-FD-8645

A	Exhaust
B	Mantle
C	Flame Height Control Knob
D	Digital Controller
E	Forklift Here
	Electrical Connection (accessible from inside or outside)
F	Service Panel or Optional Storage Box
	Gas Connection
	Must Be Left Removable for Service
	AIR INTAKE: Do Not Facade or Cover Over

SIDE VIEW

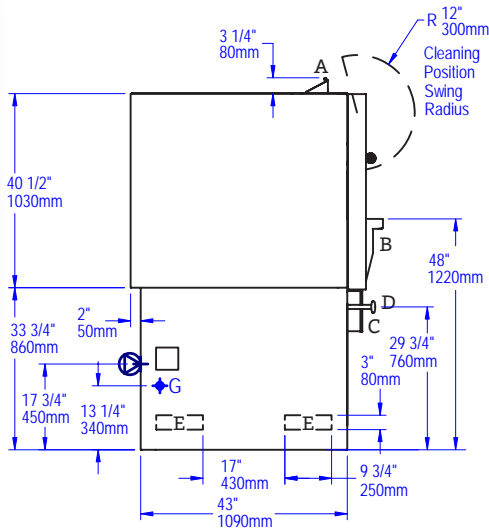

PLAN VIEW

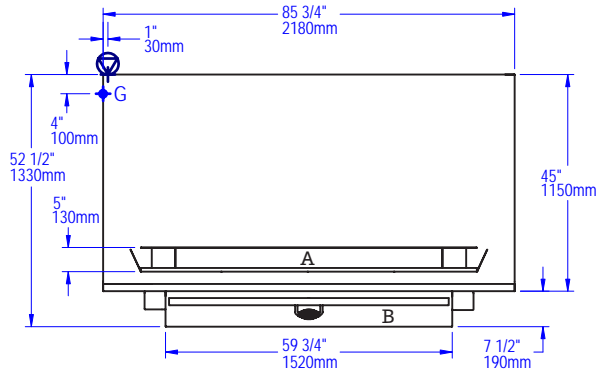

FRONT VIEW

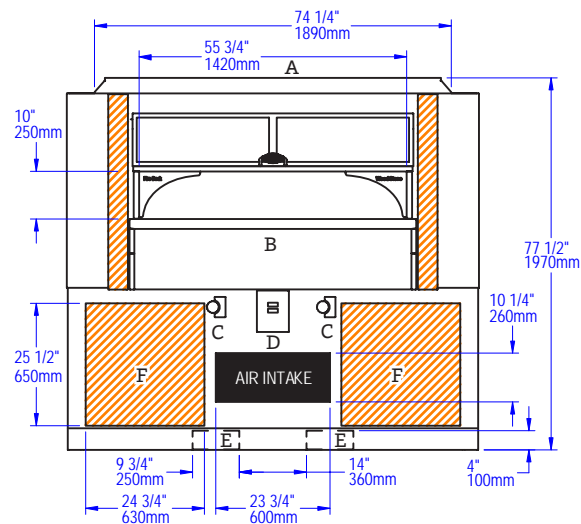

UTILITIES SPECIFICATIONS

**GAS**  
**Gas-Fired Only and Combination**  
 3/4 inch gas inlet (FNPT)  
 225,000 BTU/hr - Natural Gas (NG)  
 OR  
 200,000 BTU/hr - Propane (LP)

	BTU/hr Output Per Burner	
Radiant Flame Burner	90,000 NG	75,000 LP
IR Burner	45,000 NG	50,000 LP
Decorative Flame Adds	15,000 NG	15,000 LP

**ELECTRICAL**  
**Gas-Fired Only and Combination**  
 120 VAC, 1.1 A, 50/60 Hz  
 Connection made on left side of oven as shown.

**IMPORTANT: Models with -W in the model number must be vented as a solid fuel appliance.**

VENTING INFORMATION

The Fire Deck 8645 must be vented using a Listed Type 1 exhaust hood, or a hood constructed and installed in accordance with NFPA 96 and all relevant local and national codes. The oven must be vented in accordance with all relevant local and national codes, and in a manner acceptable to the authority having jurisdiction.

**Ship Weight: 4,350 lbs / 1,973 kg**



t. 360.650.1111  
 tf. 800.988.8103  
 f. 360.650.1166

Wood Stone Corporation  
 1801 W. Bakerview Rd.  
 Bellingham, WA 98226 USA  
[info@woodstone-corp.com](mailto:info@woodstone-corp.com)  
[woodstone-corp.com](http://woodstone-corp.com)

REVISED: SPRING 2017

An ongoing program of product improvement may require us to change specifications without notice.

