



Outperform every day.™

Project:

Item Number:

Quantity:

## SERVEWELL® HOT FOOD TABLE



ServeWell® 3-Well Hot Food Table

### DESCRIPTION

We build each ServeWell® unit with heavy-gauge stainless steel, and engineer the body, legs, and base for strength and durability. Features

- **Thermoset Fiber-Reinforced Resin Wells** – self-insulating and maximum energy efficiency. Will not rust or pit. Clean easily by wiping off water deposits from the non-metallic surface.
- **Thermostatic Heat Controls** – automatically adjust for water temperature and food volume changes to reduce food waste.
- **Capillary Tube Thermostats** – control supply power only when needed for maximum power efficiency.
- **Low-water indicator light** – eliminates guesswork.
- **Dome Heating Elements** – use up to 25% less energy and concentrate energy into the wells. Non-stick surface prevents scale build-up for easy cleaning and longer operating life. Cast-in elements for longer service life and greater energy transfer.
- **Wells** – Wide no-drip lips on wells keep top surface dry. Equipped with individual brass drain valves.
- 20 gauge stainless steel top and undershelf, 16 gauge legs.
- Operator side plate shelf and cutting board are standard on hot food table.
- Mechanical guards on all controls and power switch for safety and reliability.
- Accepts full-size or fractional pans up to 6" (15.2 cm) deep, and standard adapter plates and insets.
- Recommend using up to 4" (10.2 cm) deep food pans.
- Standard adjustable stationary legs or optional caster set.
- 10ft. (3 m) bottom-mounted power cord.
- Ships knocked down.

**NOTE:** ServeWell® Hot Food Table orders cannot be canceled or returned.

### WARRANTY

All models shown come with Vollrath's standard warranty against defects in materials and workmanship. For full warranty details, please refer to [www.vollrath.com](http://www.vollrath.com).

### Agency Certifications



Due to continued product improvement, please consult [www.vollrath.com](http://www.vollrath.com) for current product specifications.

### ITEMS

Item No.	Description	Item No.	Description
38102	700W/120V 2 Well	38004	480W/120V 4 Well
38103	700W/120V 3 Well	38005	480W/120V 5 Well
38104	700W/120V 4 Well	38116	600-800W/208-240V 2 Well
38105	700W/120V 5 Well	38117	600-800W/208-240V 3 Well
38002	480W/120V 2 Well	38118	600-800W/208-240V 4 Well
38003	480W/120V 3 Well	38119	600-800W/208-240V 5 Well
38203	480W/120V 3 Well	38215	700W/120V 5 Well
38204	480W/120V 4 Well	38217	600-800W/208-240V 3 Well
38205	480W/120V 5 Well	38218	600-800W/208-240V 4 Well
38213	700W/120V 3 Well	38219	600-800W/208-240V 5 Well
38214	700W/120V 4 Well		

### PERFORMANCE CRITERIA

ServeWell® Hot Food Table are designed to hold heated prepared foods at temperatures above the HACCP "danger zone" of 140° F (60° C). The performance standard is measured using the NSF mixture preheated to 165° F (73.9° C). The unit will hold the temperature of this product above 150° F (65.6° C). The temperature will be maintained best when the food product is held using pans with covers, the proper water level is maintained in the well, and the food product is stirred regularly.

### OPTIONS AND ACCESSORIES Dimensions in inches (cm)

#### Work/Overshelf w/o Acrylic Panel Double-Deck Overshelf

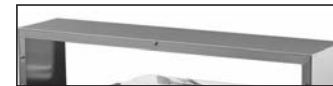

#### w/o Acrylic Panel (Not pictured)

Item	Length x Width x Height
<input type="checkbox"/> 38032	32 x 10 x 26 (81.3 x 25.4 x 66)
<input type="checkbox"/> 38033	46 x 10 x 26 (116.8 x 25.4 x 66)
<input type="checkbox"/> 38034	61¼ x 10 x 26 (155.6 x 25.4 x 66)
<input type="checkbox"/> 38035	76 x 10 x 26 (193 x 25.4 x 66)

#### Single Deck Cafeteria Guard

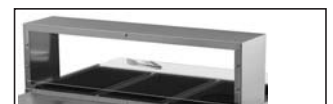

#### Buffet Breath Guards



4 holes per side for breath guard attachment.

Item	Length x Width x Height
<input type="checkbox"/> 38052	32 x 10 x 13 (81.3 x 25.4 x 33)
<input type="checkbox"/> 38053	46 x 10 x 13 (116.8 x 25.4 x 33)
<input type="checkbox"/> 38054	61¼ x 10 x 13 (155.6 x 25.4 x 33)
<input type="checkbox"/> 38055	76 x 10 x 13 (193 x 25.4 x 33)
<input type="checkbox"/> 38062	32 x 35% x 23½ (81.2 x 89.8 x 59.7)
<input type="checkbox"/> 38063	46 x 35% x 23½ (116.8 x 89.8 x 59.7)
<input type="checkbox"/> 38064	61¼ x 35% x 23½ (155.6 x 89.8 x 59.7)
<input type="checkbox"/> 38065	76 x 35% x 23½ (193 x 89.8 x 59.7)

#### Operator Side Poly Cutting Board Customer Side Plate Rest



Item	Length x Width x Height
<input type="checkbox"/> 38072	32 x 8 x 1 (81.3 x 20.3 x 2.5)
<input type="checkbox"/> 38073	46 x 8 x 1 (116.8 x 20.3 x 2.5)
<input type="checkbox"/> 38074	61¼ x 8 x 1 (155.6 x 20.3 x 2.5)
<input type="checkbox"/> 38075	76 x 8 x 1 (193 x 20.3 x 2.5)
<input type="checkbox"/> 38092	32 x 8 x 1 (81.3 x 20.3 x 2.5)
<input type="checkbox"/> 38093	46 x 8 x 1 (116.8 x 20.3 x 2.5)
<input type="checkbox"/> 38094	61¼ x 8 x 1 (155.6 x 20.3 x 2.5)
<input type="checkbox"/> 38095	76 x 8 x 1 (193 x 20.3 x 2.5)

#### Caster Set



Item	Description
<input type="checkbox"/> 38099	4" (10.2 cm) swivel wheels, two with brakes
<input type="checkbox"/> 3809934	4" (10.2 cm) swivel wheels, two with brakes, ADA height



Outperform every day.™

[www.vollrath.com](http://www.vollrath.com)

### The Vollrath Company, L.L.C.

1236 North 18th Street  
Sheboygan, WI 53081-3201 U.S.A.  
Main Tel: 800.624.2051 or 920.457.4851  
Main Fax: 800.752.5620 or 920.459.6573  
Customer Service: 800.628.0830  
Canada Customer Service: 800.695.8560

### Technical Services

techservicereps@vollrathco.com  
Induction Products: 800.825.6036  
Countertop Warming Products: 800.354.1970  
All Other Products: 800.628.0832

# SERVEWELL® HOT FOOD TABLE

**DIMENSIONS** shown in inches (cm).

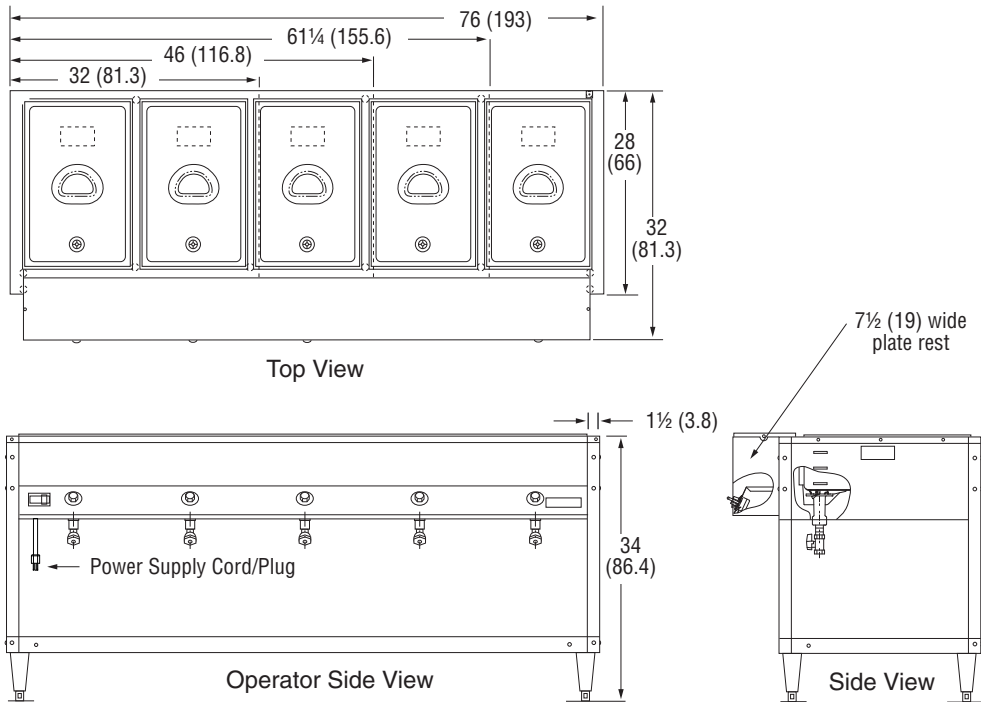

## SPECIFICATIONS

Item No.	Description	Volts (Single Phase Only)	Watts Per Well	Watts Total	Electrical Service Amps	Amps	Plug
<b>700W/120V</b>							
38102	2-well	120	700	1400	15	11.7	NEMA 5-15P
38103	3-well			2100	30	17.5	NEMA 5-30P
38104	4-well			2800	30	23.3	NEMA 5-30P
38105	5-well			3500	50	29.2	NEMA 5-50P
<b>480W/120V</b>							
38002	2-well	120	480	960	15	8	NEMA 5-15P
38003	3-well			1440	15	12	NEMA 5-15P
38004	4-well			1920	20	16	NEMA 5-20P
38005	5-well			2400	30	20	NEMA 5-30P
<b>600-800W/208-240V</b>							
38116	2-well	208-240	600-800	1200-1600	15	6.7	NEMA 6-15P
38117	3-well			1800-2400	15	10	NEMA 6-15P
38118	4-well			2400-3200	20	13.3	NEMA 6-20P
38119	5-well			3000-4000	30	16.6	NEMA 6-30P

### Receptacles

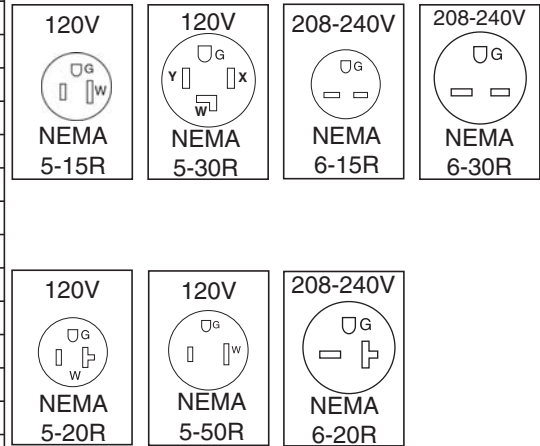

**Notes:** Dedicated circuit may be required for higher currents. ServeWell® Hot Food Table orders cannot be canceled or returned.



Outperform every day.™

[www.vollrath.com](http://www.vollrath.com)

### The Vollrath Company, L.L.C.

1236 North 18th Street  
 Sheboygan, WI 53081-3201 U.S.A.  
 Main Tel: 800.624.2051 or 920.457.4851  
 Main Fax: 800.752.5620 or 920.459.6573  
 Customer Service: 800.628.0830  
 Canada Customer Service: 800.695.8560

Technical Services  
[techservicereps@vollrathco.com](mailto:techservicereps@vollrathco.com)  
 Induction Products: 800.825.6036  
 Countertop Warming Products: 800.354.1970  
 All Other Products: 800.628.0832