



VACUUM PACKAGING

# TABLETOP VACUUM PACKAGING MACHINE

Item: 44594 | Model: VP-CN-0500



44594

## PACK AND SEAL YOUR PRODUCTS IN MINUTES!

*Omcan's tabletop vacuum packaging machine is constructed of high-quality stainless steel. Easy to operate and clean, it helps you pack your products quick and easy!*



LIMITED WARRANTY  
PARTS AND LABOR



Authorized Dealer



**FEATURES**

- *Control System: The PC control panel provides several control modes for user's selection.*
- *Material of Main Structure: 304 stainless steel.*
- *Hinges on Lid: The special labor-saving hinges on the lid markedly reduce the labor intensity of operator in daily work, so that they handle it with ease.*
- *"V" Lid Gasket: The "V" shaped vacuum chamber lid gasket made of high-density material guarantees the sealing performance of the machine in routine work.*
- *Easy to operate, clean and maintain.*

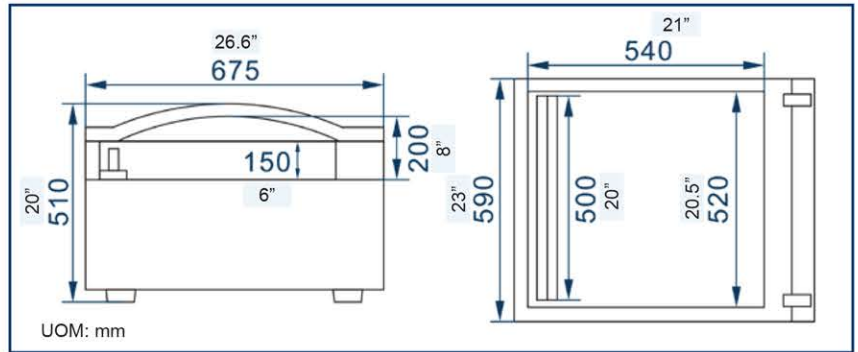

**TECHNICAL SPECIFICATIONS**

ITEM NUMBER	44594
MODEL	VP-CN-0500
POWER COSUMPTION	0.75 kW
PUMP CAPACITY (m3/h):	20 m <sup>3</sup> /h
PRODUCTION CYCLE (Bags per min.)	1-2 bags per minute
ELECTRICAL	110V / 60Hz / 1Ph
CHAMBER DIMENSIONS	21.25" x 20.47" x 7.87" / 540 x 520 x 200 mm
SEALER DIMENSIONS	20.47" x 0.078" x 0.31" / 520 x 2 x 8 mm
OVER-ALL DIMENSIONS	26.57" x 23.2" x 20" / 675 x 590 x 510 mm
GROSS DIMENSIONS	29.52" x 25.9" x 22" / 750 x 660 x 560 mm
NET WEIGHT	191.8 lbs. / 87 kg.
GROSS WEIGHT	233.69 lbs. / 106 kg.