

CONTENTS

- 04 Caster Wheels - Two Standard + Two with Brakes
- 01 Worktop
- 02 Slatted Side Frame
- 02 Supporting Cross Bars
- 08 Bolts [M8 x 60]
- 04 Small Washers [M8]
- 02 Locking Bars
- 08 Mounting Plates
- 04 Bumpers
- 04 Large Washers [M14]
- 01 Allen Wrench

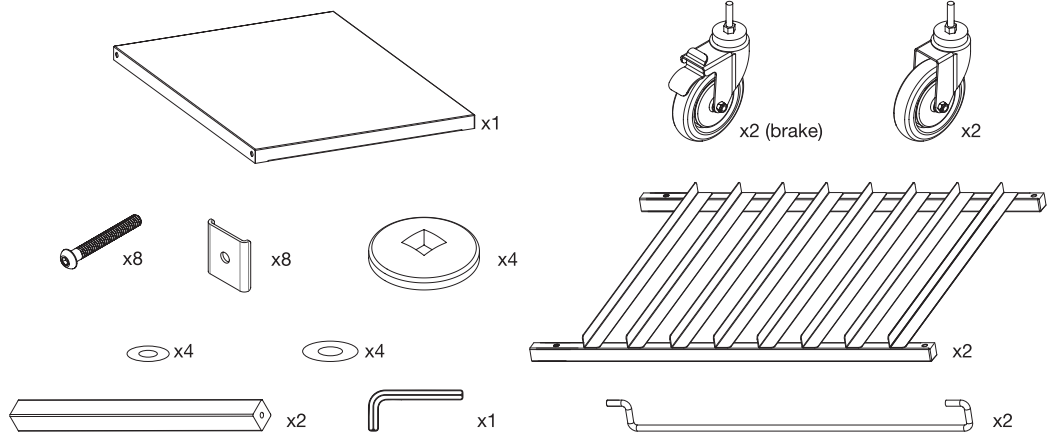

*Contents are not to scale to each other

1 ATTACH THE WORKTOP

- Place the worktop flat on the ground
- Align the holes of the side frame with the tabletop and connect with small washers and bolts using the allen wrench.
- Repeat on other side frame

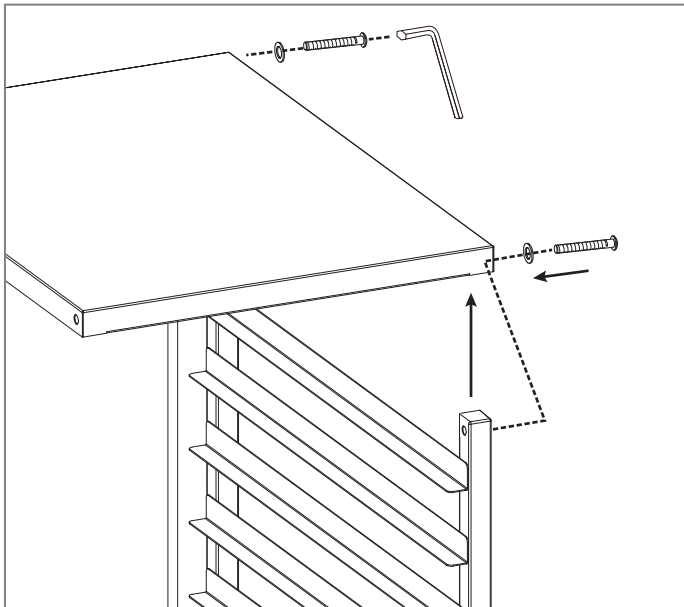

2 ATTACH CASTER WHEELS

- While assembled rack is laying flat, place bumper over large washer and caster and insert caster into bottom of rack.
- Insert bolt with plate into side of rack and through caster mount, plate, and cross bar. Hand tighten with allen wrench.
- Repeat for remaining caster wheels.

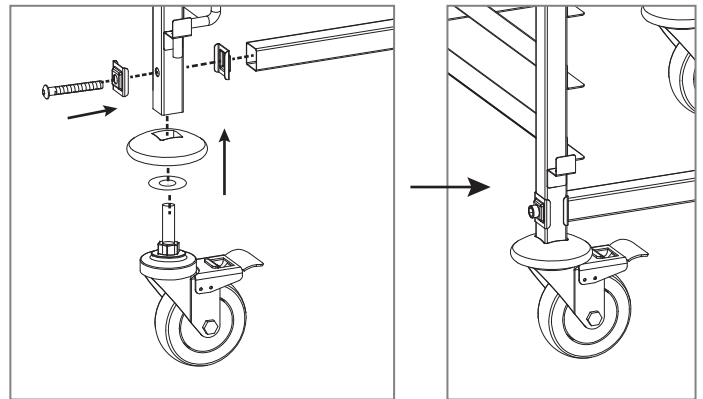

NOTE:
Mount the two casters with brakes together on the same end (either front or back).

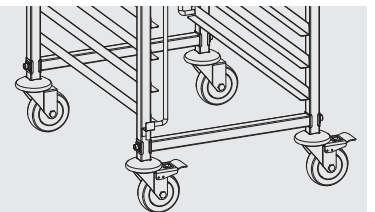

3 ATTACH LOCKING BARS

- Position rack in the upright position
- Slide each hook of locking bar into fitted hole on the top and bottom of rack.

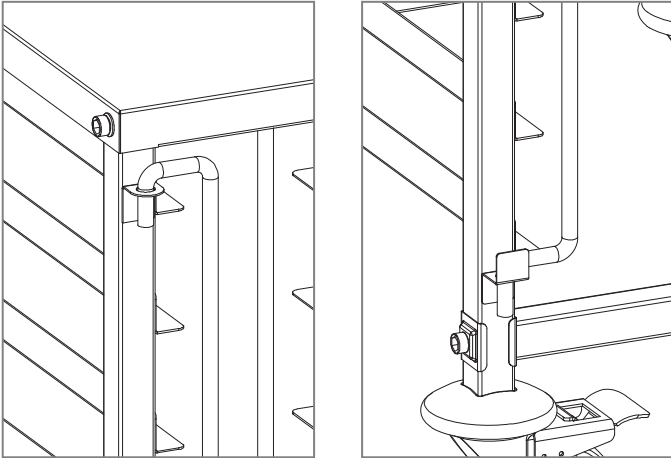
**4 FINAL CHECK**

- Stand the rack upright on a level surface/floor.
- All casters must be touching the floor evenly.
- Firmly tighten all bolts to ensure they are secure.

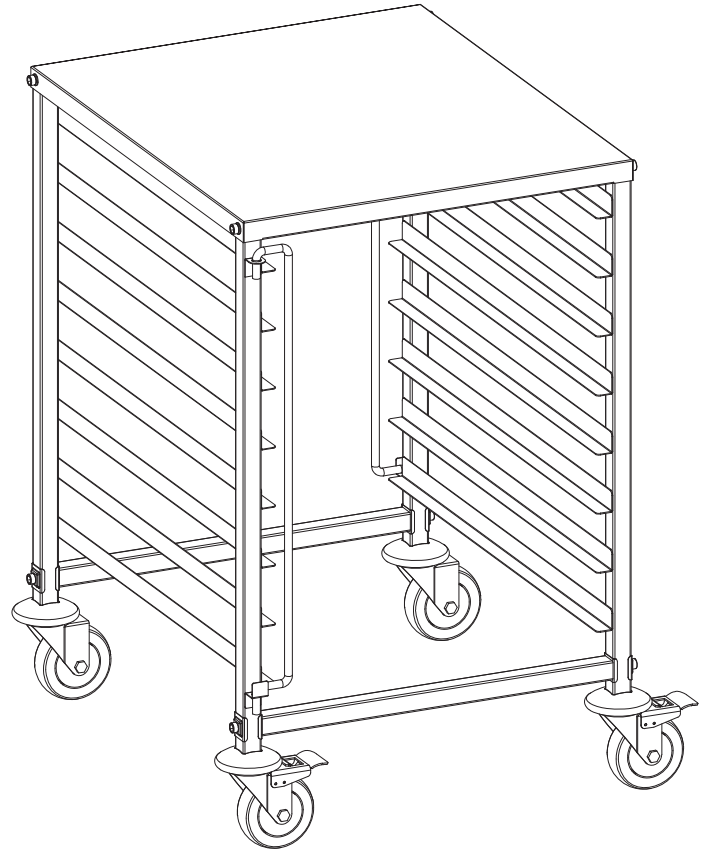
**CAUTION****DO NOT OVERTIGHTEN BOLTS .**

Overtightening may cause stripped threads and the bolt will not function properly.

MAX LOADING CAPACITY:**500 Lbs**

Worktop capacity: 100 lbs

Shelf capacity: 50 lbs each