



SD-24 & SD-30 EQUIPMENT STAND

Job _____

Item# _____



STANDARD FEATURES

- All stainless steel construction with 1-1/4" square tube frame.
- Removable drain drawer and splash shield.
- High front splash shield for added control.
- Removable splash diffuser.
- Roller action slides for drawer.
- Stationary drain connection.
- Four (4) adjustable flanged feet for floor mounting.

SPECIFICATIONS:

Shall be a CROWN Model _____, Open Type Equipment Stand with removable Drain Drawer with nylon roller action guides and high front splash shield, for added splash control and removable splash diffuser. All stainless steel construction with 1-1/4" square frame and legs, stationary drain connection and four (4) flanged adjustable feet for floor bolting.



Models: SD-24 SD-30

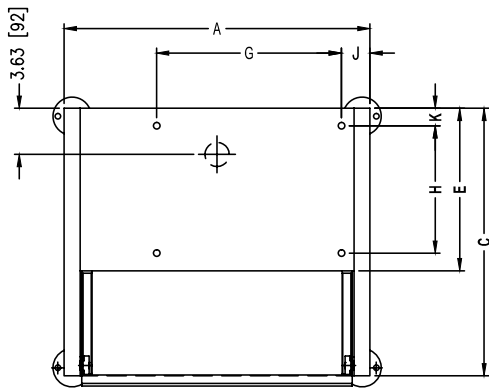

FLANGED FOOT DETAIL
 2 EQUALLY SPACED
 $\varnothing 7/16"$ [11mm] HOLES
 ON 2.5" [63mm] B.C.

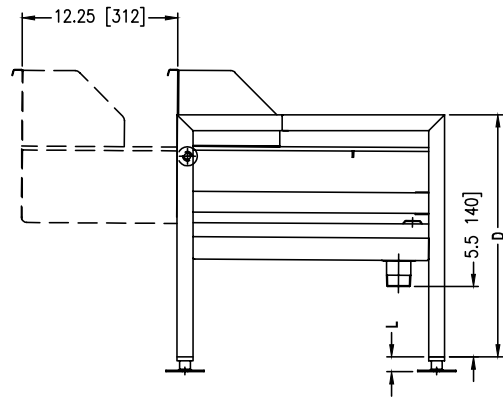
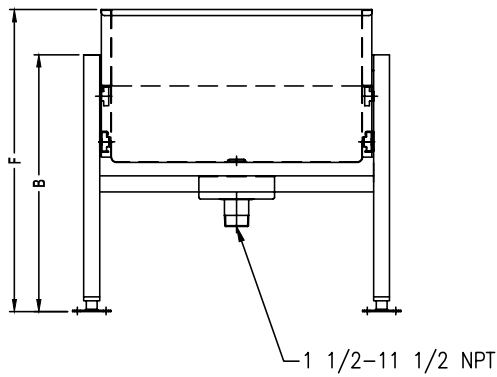

IN [mm]
 7072R1

DIMENSIONS

MODEL	UNITS	A	B	C	D	E	F	G	H	J	K	L
SD-24	inches	24 (610)	20.13 (511)	21 (533)	19 (483)	12.75 (324)	23.75 (603)	14.5 (368)	10 (254)	2.25 (57)	1.38 (35)	1.13 (29)
SD-30	mm	29.25 (743)										

**INTENDED FOR COMMERCIAL USE ONLY.
 NOT FOR HOUSEHOLD USE.**



70 Oakdale Road, Toronto ON, Canada M3N 1V9
 (919) 762-1000 www.crownsteamgroup.com