

Heavy Duty 10 Quart Planetary Mixer

MODELS:
PPM-10

Standard Features

- Three fixed speeds
- Gear driven transmission with aluminum alloy gear box
- 30-minute timer
- Safety cut-switch temporarily interrupts power if gears are changed without stopping the mixer
- Easy to reach controls
- Interlocked bowl lift and stainless-steel bowl guard with swing out bowl
- 6' cord with NEMA 5-15 plug
- Steel body with open base



Standard Accessory Package

- Stainless steel bowl
- Stainless steel flat beater
- Stainless steel wire whisk
- Stainless steel spiral dough hook
- Non-slip rubber feet

Optional Accessories

- Flat beater
- Dough hook
- Wire whip
- Extra stainless steel bowl



1 YEAR PARTS AND LABOR WARRANTY (US ONLY)



SPECIFICATIONS

Model	HP	Watts (W)	Voltage (V/Hz/Ph)	Amps (A)	Capacity (Quarts)	Exterior Dimensions (inch)	Net Weight (lbs)	Gross Weight (lbs)	Agitator Speed (RPMs)		
									First (low)	Second (intermediate)	Third (high)
PPM-10	1	750	115/60/1	10	10	15 ^{1/2} ×15 ^{1/2} ×24	79	88	108	195	355

PLAN VIEW

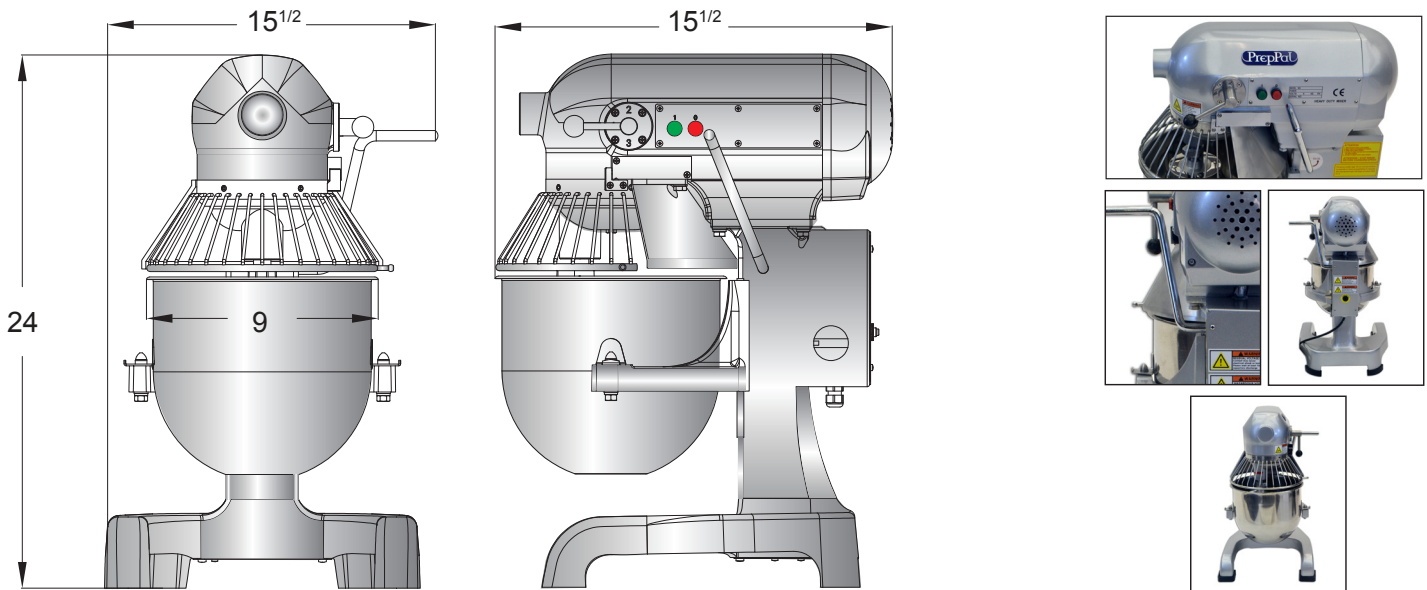

STANDARD ACCESSORY PACKAGE

Mixing Bowl



Dough Hook



Wire whip



Flat beater

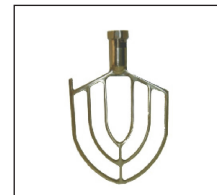

NEMA 5-15P



NEMA
15A/125V