

ELECTRIC STEAM TABLES

72-INCH STAINLESS STEEL ELECTRIC OPEN WELL HOT FOOD TABLE WITH 5 PANS CAPACITY, CUTTING BOARD AND UNDERSHELF

Item: 46648 Model: FW-CN-0005-FH

**KEEP YOUR HOT FOODS
READILY AVAILABLE AT
SAFE TEMPERATURE**

Maintain your hot dishes at an optimal serving temperature with Nella's 72-inch Stainless Steel Electric Open Well Hot Food Table. Designed with durability and functionality in mind, this hot food table is an indispensable asset for any commercial kitchen. It features 5 wells for food pans, a convenient under-shelf storage, and a durable polyethylene cutting board for additional prep space when filling food pans or plates.



Pans not included.



WARRANTY
PARTS AND LABOR



SHIPPED ON PALLET



ELECTRIC STEAM TABLES

TECHNICAL SPECIFICATIONS

ITEM NUMBER	46648
MODEL	FW-CN-0005-FH
MAX. TEMPERATURE	Approximately 212°F / 100°C
POWER	5000W
ELECTRICAL	240V / 60Hz / 1Ph
AMPS	20.83
MATERIAL	Stainless Steel
CUTTING BOARD MATERIAL	Polyethylene
NUMBER OF PANS	5 (Pans not included)
PAN SIZE	20.78" x 12.8" x 6" (full size)
UNDERSHELF SIZE	69.7" x 18" x 2" 1770 x 462 x 50 mm
CUTTING BOARD SIZE	72" x 7.9" x 0.5" 1830 x 200 x 12 mm
DIMENSIONS (WDH)	72" x 30" x 34" 1830 x 772 x 870 mm
GROSS DIMENSIONS	75" x 25" x 20" 1910x640x520mm
WEIGHT	68kgs. 150lbs.
GROSS WEIGHT	88kg. 194lbs.

FEATURES

- Stainless steel structure with individual control
- Adjustable stainless steel undershelf and removable Polyethylene cutting board
- Adjustable stainless steel feet
- Stainless steel heating element
- 5 independent infinite controls
- Pans not included

OPTIONAL ACCESSORIES

- Full Size Pan (Item 80259)
- Spillage Pan (Item 80907)

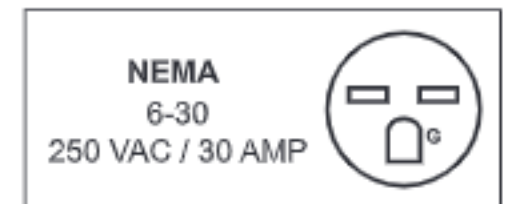

TECHNICAL DRAWINGS AND DIMENSIONS

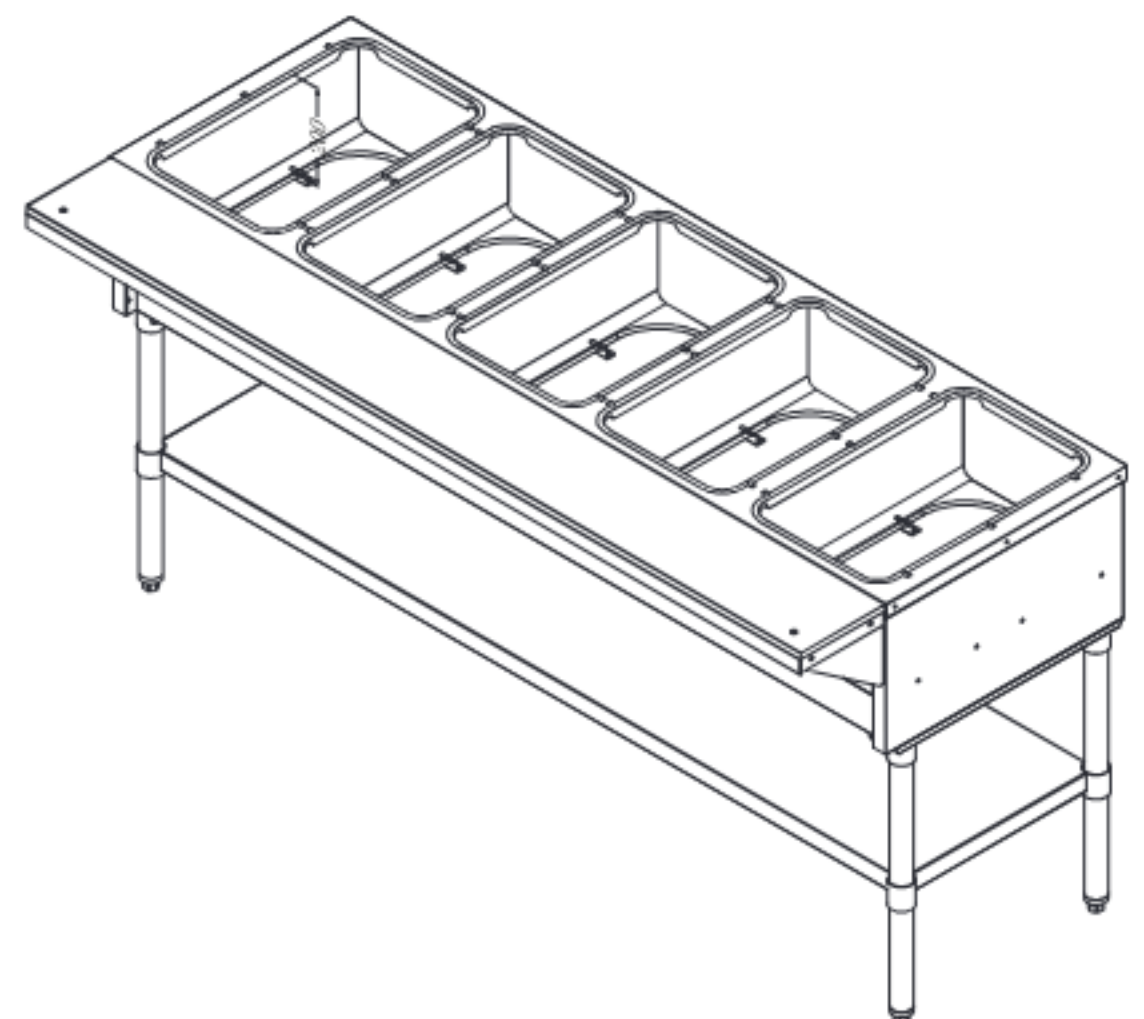
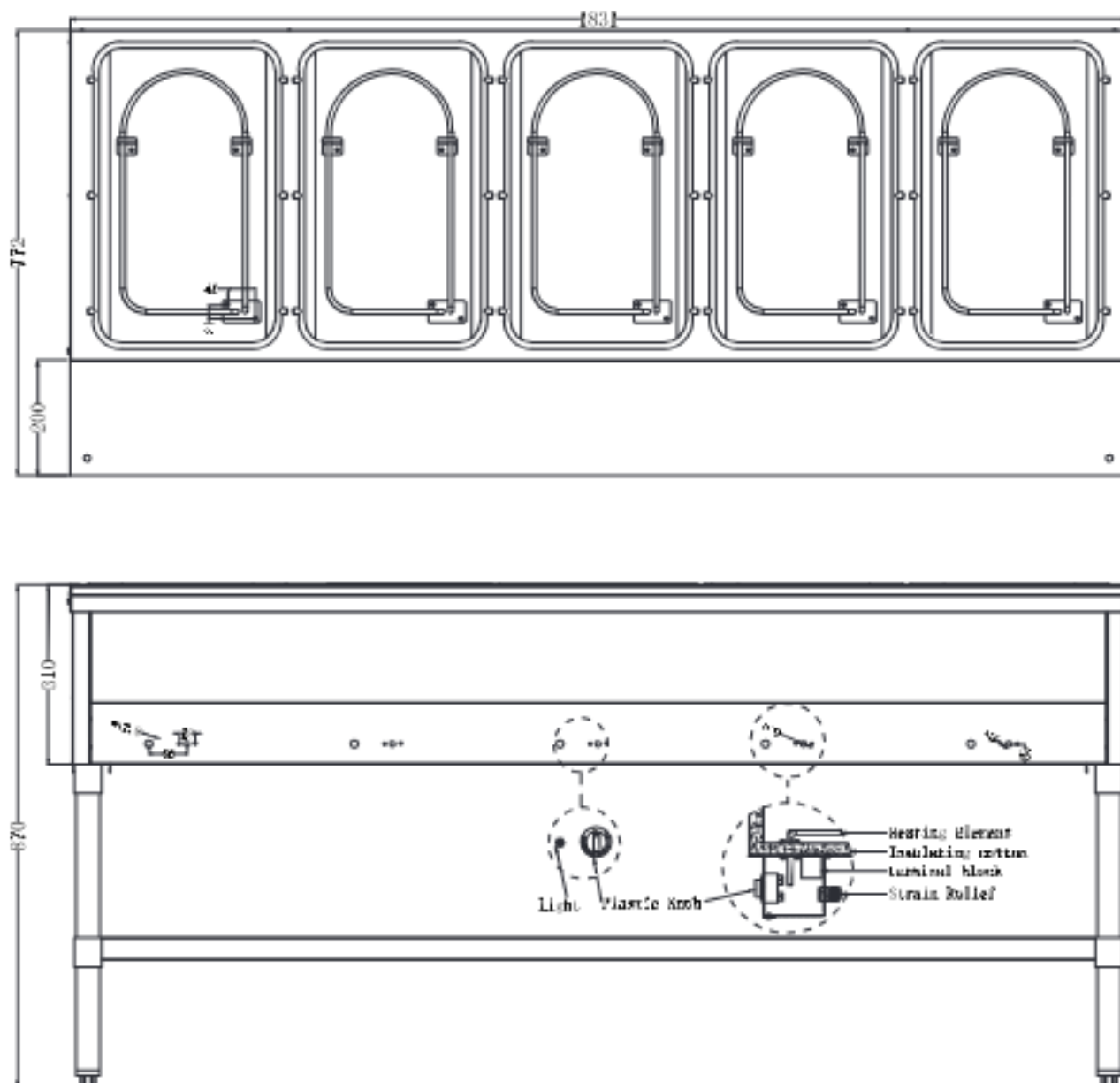

LOCATIONS

148 NORFINCH DR
NORTH YORK, ON
M3N 1X8
416-740-2424

433 QUEEN ST E.
TORONTO, ON
M5A 1T5
416-847-1112

1164 ELLESMERE ROAD
SCARBOROUGH, ON
M3N 1X8
416-292-0828

WWW.NELLAONLINE.COM
HELP@NELLAONLINE.COM