

MILANO-170 STATIC OVEN

Code:

- M-170

Baking Surface:

- Static

Fuel Options:

- M-170W-Wood
- M-170G-Gas
- M-170C-Combi

Overview

The Milano oven is appealing, free-standing and can be built into an enclosure. Available in a variety of custom colours, it is sure to create a unique focal point in your restaurant. The oven's straight, metal exterior makes it the perfect solution for enclosed construction projects.

A static baking surface is ideal for the experienced pizza master who loves tradition and self-regulated work. It works well for restaurants with a limited volume of pizza production and a lower budget for investing into pizza making.

Pizza Capacity

10"	12"	14"	16"	18"	20"
16+	15	11	8	6	5

Standard Features

- Constructed with vibrated refractory stone
- Suitable for various foods: pizza, pita, bread, slow cooking meat & fish
- Heats up rapidly up to 950° Fahrenheit (510°C)
- Efficient temperature maintenance with no heat loss
- Heavy duty steel stand
- Refractory stone baking surface

Certification

- ETL approved for Canada/USA

Warranty Information

- 4 Year deck and dome refractory stone warranty
- 1 Year parts and labour warranty



Images for demonstrative purposes only. Equipment shown may not be included in your custom quote. Consult quote for custom options.

Standard Finish

- Plain unfinished
- Additional colours or finishes are extra (see quote)

Customization Options

- Delivered assembled or assembled on site.
- Custom mosaic colour, pattern and branding
- Several door options, sizes and colours available
- Granite mantle
- Left or right burner position (gas/combi ovens)
- Propane or Natural Gas (gas/combi ovens)
- Mechanical, digital or touch screen gas controls
- Debris collector
- Oven tools

MILANO-170 STATIC OVEN M-170

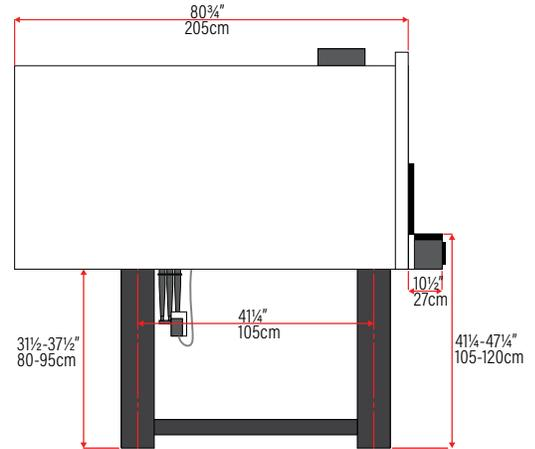
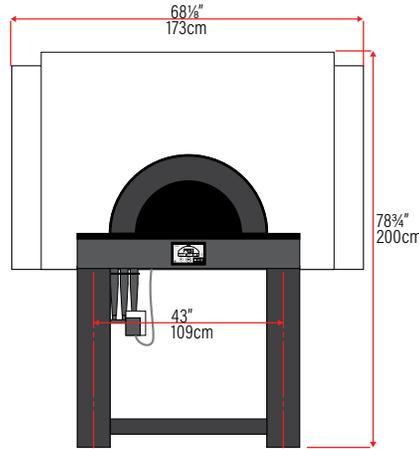
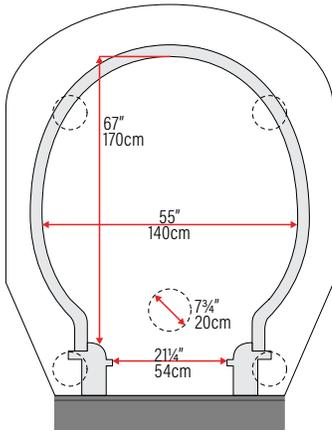

Clearance requirement is 3" (8cm) on all sides and 6" (16cm) on the top. Optional granite mantle pictured

Fuel Position

Left side standard, right side optional.

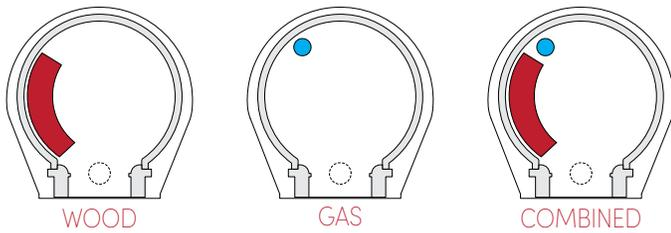

Venting Requirements

Vent Type	Wood	Gas	Combi
Direct Vent	✓	✓	✓
Hood Vent		✓	

- The oven is vented through a 7 3/4" round duct collar.
 - Direct Venting** requires a double wall chimney pipe.
 - Direct vent flue adapter available: 7 3/4"-8"
 - Hood Venting** requires installation under a type 1 exhaust hood.
- Installation & venting is subject to the local authorities approval.

Gas Requirements (if equipped)

- 66,000 BTUs, 3/4" NPT
- Inlet pressure for natural gas 7" water column
- Inlet pressure for liquid propane gas 11" water column

Gas components must be accessible at all times for maintenance purposes.

Electrical Information

All ovens equipped with a gas option must select one of the 3 controller options below.

Controller	Power	Plug	Cord	
Mechanical Gas	2x AA Battery	N/A	N/A	
Digital Gas Touch Screen	220V/1phase	NEMA 6-15P ⊕	9'	274cm

Oven Specifications

Baking Area	Width	Depth	Height	Weight
ø 67x55"	68 1/8"	80 3/4"	78 3/4"	2866Lbs
ø 170x140cm	173cm	205cm	200cm	1300Kg

Shipping Specifications (Assembled in crate)

Width	Depth	Height	Weight
76"	78"	86"	3285Lbs
192cm	212cm	218cm	1490Kg

Shipping weight and dimensions may vary based on oven options selected.