



Salamander **BROILER**

Features

- The Ikon " Salamander Broiler" provides 3-level broiling positions
- Stainless Steel front and Sides
- 35,000 BTU Infra-red burner
- Manual gas control from 300°F to 750°F
- Standing pilot igniton system
- Full width broiler pan
- 3/4" rear gas connection with regulator
- 3 Position Adjustable spring balanced rack
- Ball grip handle on adjustable rack for ease and comfort
- Ready to mount over any Ikon 36, 60 inch range
- 4" adjustable height, non-skid SS Legs included for countertop operation
- **Available in Natural gas(NG) or Liquid propane(LP).**
A conversion kit is supplied with each unit



ISB-36





Salamander BROILER

Dimensions in inches

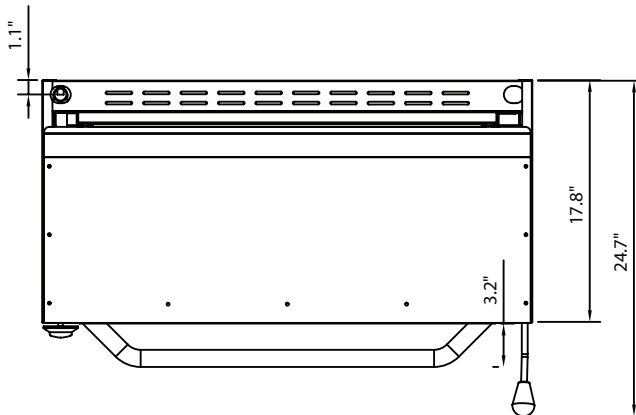
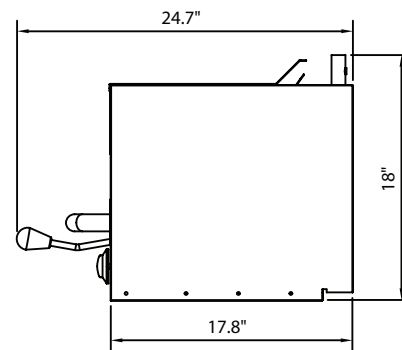
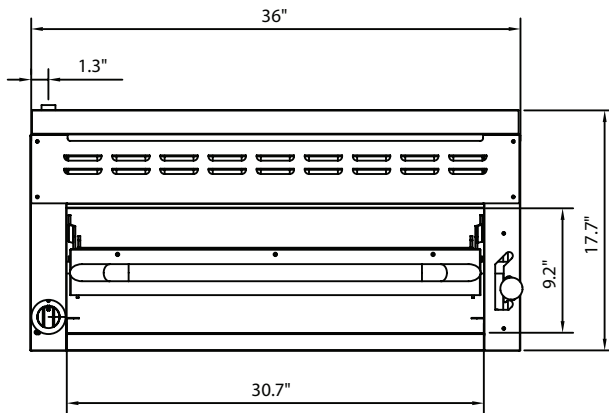

Specifications

GAS REQUIREMENTS

- Natural Gas or Liquid Propane (LP) Gas main supply required
- A conversion kit is supplied with each unit. In order to avoid any warranty issues, conversion of your unit must be completed by an authorized Ikon service agent.
- 3/4" NPT gas connection
- Natural gas 5" W.C., LP gas 10" W.C.



Model	# of Burners	Total BTU	Overall Dimensions	Weight	Shipping Dimensions	Shipping Weight
ISB-36	1	35,000	36.0"W x 24.7"D x 18.0"H (91.4cm x 62.7cm x 45.7cm)	143lbs (65.0 kg)	39.4"W x 25.6"D x 21.6"H (100cm x 65cm x 55cm)	150 lbs (68.2 kg)



Tel.: 786.600.4687 / Toll Free: 844.218.8477
Fax: 786.661.4100



Tel.: 514.737.9701 / Toll Free: 888.275.4538
Fax: 514.342.3854 / Toll Free: 877.453.8832
sales@mvpgroupcorp.com

3560 NW 56th St.
Fort Lauderdale, FL 33309 USA
5659 Royalmount Ave.
Montreal, QC H4P2P9 CANADA



www.mvpgroupcorp.com