

Model Numbers

IR-6	IR-G36
IR-6-C	IR-G36-C
IR-6 -XB	IR-G36-XB
IR-4-G12	IR-4-S18
IR-4-G12-C	IR-4-S18-C
IR-4-G12-XB	IR-4-S18-XB

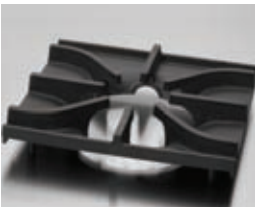

Two rings of flame for even cooking no matter the pan size.



Front grate with anti-clogging pilot shield protects the pilot from grease and debris.



Back grate hot air dam deflects heat onto the stock pot, not the backsplash.



Large 5" (127 mm) stainless steel landing ledge for convenient plating.



Durable cast aluminum with a vylox heat protection grip.



IR-6 shown with optional casters

OPEN BURNERS - PyroCentric™ 32,000 BTU (9 KW) anti-clogging burner with a 7,000 BTU/hr. (2 KW) low simmer feature. Cast iron PyroCentric burners are standard on all IR Series Ranges.

- Burners are anti-clogging and lift-off and separate for easy cleaning. No gaskets or screws.
- One standing pilot per burner for instant ignition.

GRATES - Front grates measure 12" x 11" (305 x 279 mm). Back grates are 12" x 13" (305 x 330 mm).

- Back grates are sized for positioning large stock pots directly over burner and feature a hot air dam.
- Extra wide grates are 12" x 18" (305 x 457 mm) front and back.
- Pots slide easily from section to section and onto landing ledge.
- Grates are cast iron for a long service life.

GRIDDLE - highly polished 3/4" (19 mm) steel plate. 21" (533 mm) plate depth.

- Burners have 20,000 (6 KW) BTU/hr. output with a heat deflector every 12" (305) for even heating.
- 3" (76 mm) wide grease trough and removable grease can for easy cleaning.

STANDARD CHEF DEPTH OVEN - Linear burner provides even heating throughout the 35,000 BTU (10 KW) oven. 100% safety pilot.

- Unique burner baffle distributes heat flow to provide even temperatures throughout the oven cavity.
- Exclusive heat deflector reflects heat into the oven, not the floor.
- Interior is 26-1/2" w x 26" d x 14" h (673 w x 660 d x 356 h mm). Accommodates 18" x 26" (457 x 660) sheet pans left-to-right and front-to-back.
- Porcelainized sides, rear, deck and door lining for easy cleaning. Heavy duty door hinge.
- Stamped inner door liner provides extra strength while optimizing heat retention.
- One chrome oven rack is included.

CONVECTION OVEN - 30,000 BTU/hr. (9 KW) convection oven with 1/4 hp blower motor cooks products quickly and evenly with less shrinkage.

- Convection oven interior dimensions 26-1/2" w x 22-1/2" d x 14" h (673 x 572 x 356 mm).
- Three position switch for cooking or cool down. Fan shuts off automatically when door is open.
- Porcelainized sides, rear, deck and door lining for easy cleaning. Heavy duty door hinge.
- Three chrome oven racks.

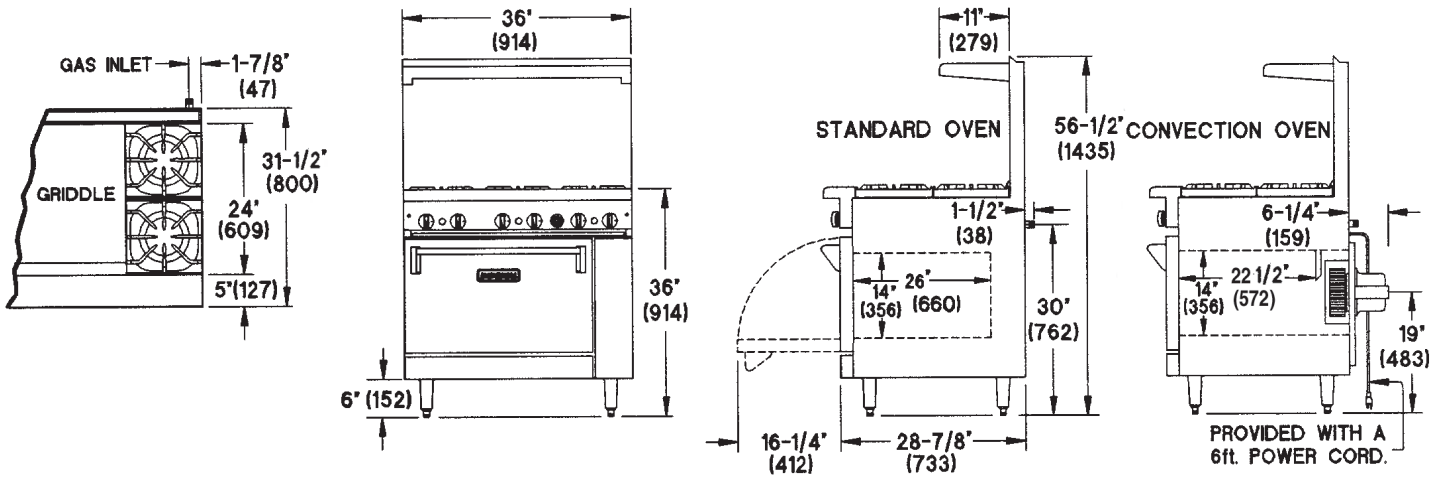

36" RESTAURANT RANGES

TOP	MODEL	GAS OUTPUT BTU (KW)	OPEN BURNERS	GRIDDLE WIDTH	SHIP WEIGHT (KW) LBS
	IR-6	227,000 (67)	6	N/A	(274) 605
	IR-6-C	222,000 (65)	6	N/A	(301) 665
	IR-6-XB	192,000 (56)	6	N/A	(246) 545
	IR-4-G12	183,000 (54)	4	12" (305 mm)	(283) 625
	IR-4-G12-C	178,000 (52)	4	12" (305 mm)	310) 685
	IR-4-G12-XB	148,000 (43)	4	12" (305 mm)	(256) 565
	IR-2-G24	139,000 (41)	2	24" (610 mm)	(288) 635
	IR-2-G24-C	134,000 (39)	2	24" (610 mm)	(314) 695
	IR-2-G24-XB	104,000 (30)	2	24" (610 mm)	(260) 575
	IR-G36	95,000 (28)	N/A	36" (914 mm)	(297) 655
	IR-G36-C	90,000 (26)	N/A	36" (914 mm)	(319) 705
	IR-G36-XB	60,000 (18)	N/A	36" (914 mm)	(269) 595
EXTRA WIDE 	IR-4-S18	163,000 (48)	4	N/A	(272) 600
	IR-4-S18-C	158,000 (46)	4	N/A	(298) 660
	IR-4-S18-XB	128,000 (38)	4	N/A	(244) 540
STEP-UP 	IR-6-SU	227,000 (67)	6	N/A	(274) 605
	IR-6-C-SU	222,000 (65)	6	N/A	(301) 665
	IR-6-XB-SU	192,000 (56)	6	N/A	(246) 545

Measurements in () are metric equivalents.

NOTES

- "C" specifies (1) 26-1/2" (673 mm) Convection Oven
- "XB" specifies (1) Cabinet Base
- "G" specifies Griddle Top
- "SU" specifies Step-up

EXTERIOR

- Stainless steel front, sides, backguard, shelf, landing ledge and kick plate
- Welded and polished stainless steel seams
- Large 5" (127 mm) stainless steel landing ledge
- Control knobs are durable cast aluminum with a vylox heat protection grip
- Full width, removable crumb tray for easy cleaning
- 6" (152 mm) heavy duty legs with adjustable feet
- One year parts and labor warranty

OVERALL DIMENSIONS	CRATED DIMENSIONS
36" w x 31-1/2" d x 36" h* (914 x 800 x 914 mm)	38-1/2" w x 39" d x 35"*** h (978 x 991 x 889 mm)
* to cooktop	
** add 4" (102 mm) for Step-up models	

MANIFOLD PRESSURE	NATURAL GAS	PROPANE GAS	MANIFOLD SIZE
5.0" W.C.	10.0" W.C.	3/4" (19 mm)	
Specify type of gas and elevation, if over 2,000 ft.			

CLEARANCE REQUIREMENTS

For use only on non-combustible floors. Legs or casters are required for non-combustible floors; or 2" (51 mm) overhang is required when curb mounted. Provide 0" clearance from non-combustible surfaces and 8" (203 mm) from combustible surfaces.

OPTIONS AND ACCESSORIES

- Reinforcement channels for mounting cheesemelter/salamander
- 10" (254 mm) stainless steel wok ring
- Saute burner head, interchangeable
- Wok burner head, interchangeable
- 220V motor and transformer for convection oven
- Extra oven racks
- Thermostatic griddle control (specify griddle size)
- Grooved griddle top
- Chrome griddle top
- Griddle safety valve
- Gas shut off valve 3/4" (19 mm)
- Quick disconnect and flexible gas hose
- 6" (152 mm) casters



1128 Sherborn Street Corona, CA 92879
 800.343.7790 Ph: 951.281.1830 Fx: 951.281.1879
 www.imperialrange.com
 E-mail: imperialsales@imperialrange.com