



Equipment for the Foodservice Industry
value + quality + service

GLASS DOOR MERCHANDISER FREEZER

F3-82GDVC



F3-82GDVC Features

Features:

- Bottom mount compressor units
- LED lighting interior display system
- Dixell digital temperature control system
- Heavy duty Embraco compressor
- Self-closing and stay open door
- Efficient refrigeration system
- Recessed door handle
- Standard safety door lock
- Magnetic door gaskets

- Pre-installed castors
- Pre-installed shelves

Warranty

- 2 year parts and labour; 5 years on compressor
- Specifications subject to change without notice



F3-82GDVC Specifications

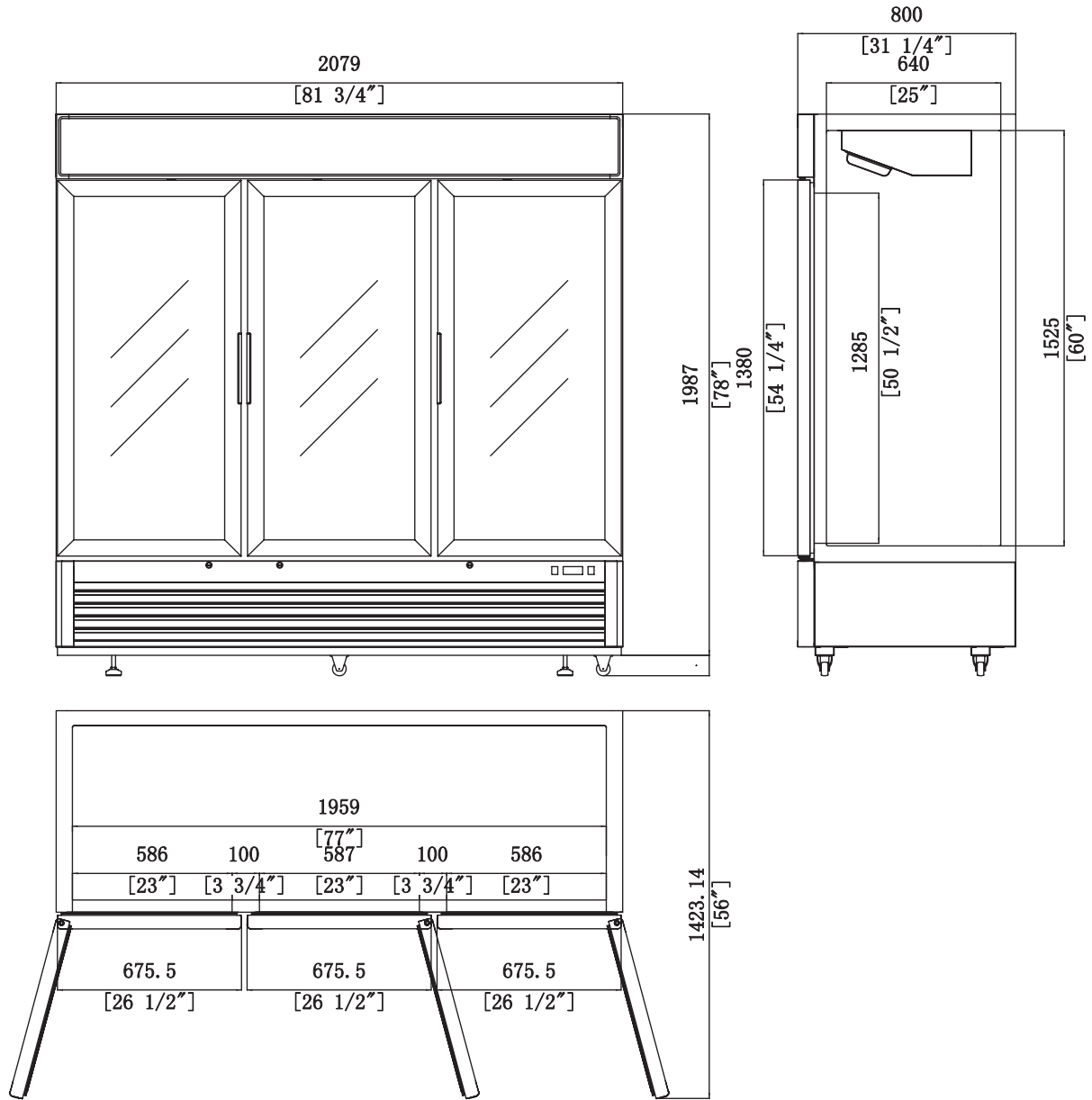

Model	Refrigerant	Doors	Shelves	Dimension (mm) (inch)			HP	Voltage	Amps	Capacity (L) (Cu Ft.)	Net Weight (KG) (LBS)	Temperature Range	NEMA Config.
				L	D	H							
F3-82GDVC	R404a	3	12	2079	800	2062	1	115V/208-230V	5.5	2050	200	-4 ~ 1.4°C	5-15P
				81.9	31.5	81.2				72.4	440	-20 ~ -17°F	