

DMX AND DMX QUAD 300 MIXER



- NSF And CFIA Listed
- Made in the USA
- Foward and Reverse Mixing
- Four Position Dump
- All Stainless Steel Contruction
- Capacity 300 Lbs. (136 Kg.)
- Four Swivel Locking Casters
- 300 Quad Has Two Paddles

For all your mixing needs. The 300 mixers are reliable well built machines. Easy to remove paddles, no wrenches needed. Two safety switches. Forward and reverse mixing. LED timer, displays hours and minutes. Two hopper locks. The DMX QUAD 300 has two paddles, that rotate in opposite directions. The DMX 300 has one paddle. Drain plug on hopper. Clear hopper lid.

Available options: Stainless Steel Grated Lid, Metal Lid, Tube lid, Pour Spout, Frame Extension and Hydraulic Lift.

Daniels **F**ood **E**quipment
310 North Clayborn Ave
PO Box 341
Parkers Prairie, MN 56361

Phone: 218-338-5000
Fax: 218-338-5909
E-mail: danielsfood@midwestinfo.net
Web: www.danielsfood.com

DANIELS FOOD EQUIPMENT

DMX and DMX QUAD 300 MIXER

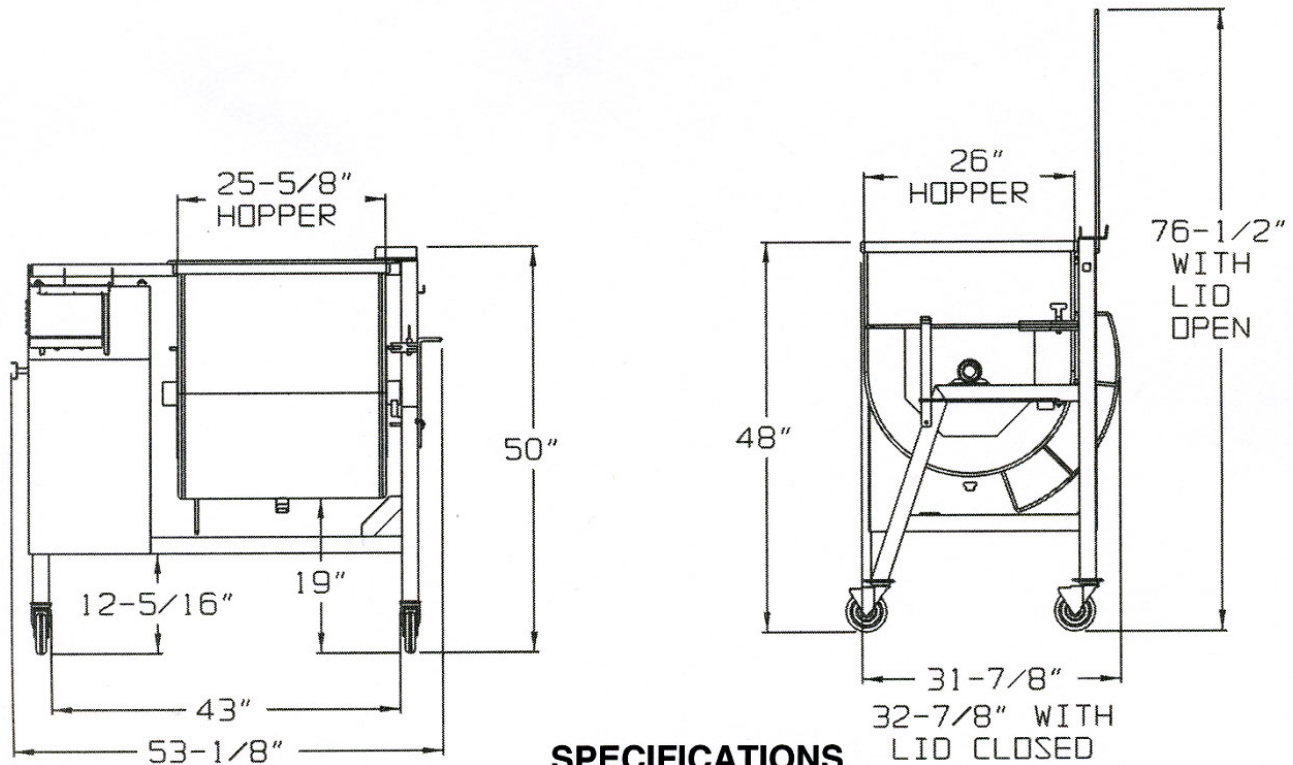

SPECIFICATIONS

MOTOR:	STANDARD: 3 HP, 3 PH, 230 VOLT, 60 Hz, 8.8 AMP OPTIONAL: 3 HP, 3 PH, 208 VOLT, 60 Hz, 9.0 AMP OPTIONAL: 3 HP, 3 PH, 460 VOLT, 60 Hz, 4.4 AMP
PADDLE RPM:	DMX: 24-1/3 RPM DMX QUAD: INNER 24-1/3 RPM, OUTER 24-1/3 RPM
TIMER:	LED READOUT – HOURS and MINUTES
DIRECTION CONTROL:	FORWARD-STOP-REVERSE
HOPPER CAPACITY:	300-LBS
HOPPER CONSTRUCTION:	12 GA STAINLESS STEEL, 110° DUMPING, REMOVABLE PADDLE, CLEANOUT DRAIN ON BOTTOM, TRANSPARENT COVER WITH SAFETY LOCKOUT.
FRAME:	11 GA STAINLESS STEEL TUBING, OPEN UNDER HOPPER FOR EASY DUMPING, LOCKING SWIVEL CASTERS.
DUMP HEIGHT:	12-7/8"
WEIGHT:	DMX: 585-LBS, SHIPPING INFO: 660-LBS, SIZE: 36" X 60" X 53" HIGH DMX QUAD: 610-LBS, SHIPPING INFO: 685-LBS, SIZE: 36" X 60" X 53" HIGH

DANIELS FOOD EQUIPMENT

310 NORTH CLAYBORN AVE. PARKERS PRAIRIE, MN. 56361 PHONE: (218) 338-5000 FAX (218) 338-5909

WEB: www.danielsfood.com

E-MAIL: danielsfood@midwestinfo.net

4/28/2010