

# Champion®

The Dishwashing Machine Specialists

Project \_\_\_\_\_  
Item No. \_\_\_\_\_  
Quantity \_\_\_\_\_

**DH-6000 HOOD-TYPE**

## STANDARD FEATURES

- **Factory Authorized Startup**
- **HMI – Operator Touch Screen Interface**
- **On-Board Service Diagnostics**
- **Field Convertible – Single to three, or three to single phase**
- **Sleep Mode – All internal heaters shut off after 4 hours idle**
- Auto delime with delime notification
- Field convertible from straight to corner operation
- Dual NSF listed as both a dishwasher and potwasher
- Rinse Sentry – ensures 180°F final rinse, requires built-in booster
- Cycle counter
- Auto start – starts unit when hood is closed
- Single or dual point electrical connection
- High efficiency 2 HP pump
- Self draining pump
- Automatic tank fill
- Automatic drain valve – drains wash tank when power is off
- PRV (Mounted Pressure Reducing Valve)
- Vent fan control
- 4 selectable cycles

## DH-6000

High Temperature  
Hood-type Dishwashing Machine



## OPTIONS & ACCESSORIES

- NEW** Built-in detergent and rinse aid pumps
- Drain Water Tempering kit (unmounted)
- Ventless/Heat Recovery/Condensate Removal option
- Door Interlock – locks door closed during the vent fan cycle
- Racks
  - Peg
  - Flat
- Corner Operation splash baffle
- NEW** Champion ION scale prevention system
- Built-in booster configured to ensure 180° rinse



Photo is for general visual representation only. Please refer to specifications for the latest detailed product information.

## SPECIFIER STATEMENT

Specified unit will be Champion model DH-6000 high temperature hood-type dish-washing machine. Features HMI controls, Rinse Sentry, Auto start, up to 60 racks/hour, 0.73 US gals/rack [2.76 liters/rack, 0.61 imp. gals/rack].  
1 year parts and labor warranty.

Champion Industries, Inc.  
3765 Champion Blvd., Winston-Salem, NC 27105  
Tel: 336/661-1556 Fax: 336/661-1979

2674 N. Service Road  
Jordan Station, Ontario, Canada L0R 1S0  
Tel: 800/263-5798 Fax: 905/562-4618

[www.ChampionIndustries.com](http://www.ChampionIndustries.com)

# Champion®

The Dishwashing Machine Specialists

# DH-6000

High Temperature Hood-type Dishwashing Machine

Shipping weight crated: 300 lbs.

Dimensions shown in inches and [mm]

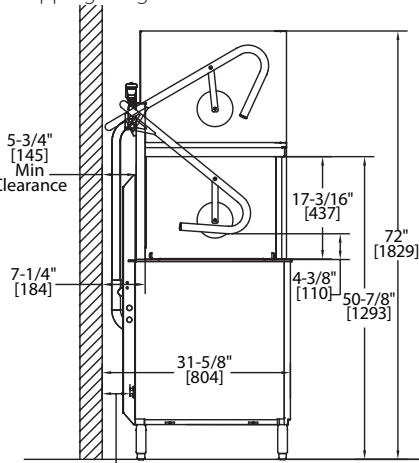

Side View

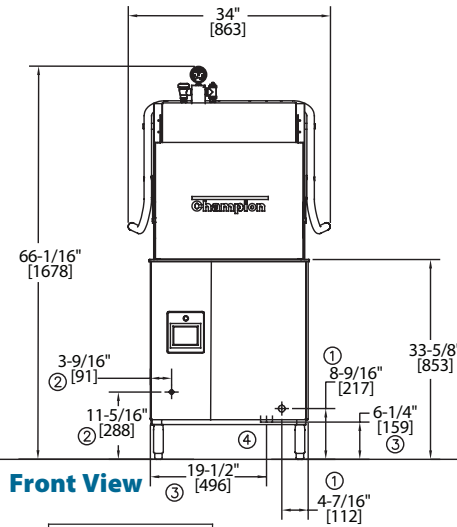

Front View

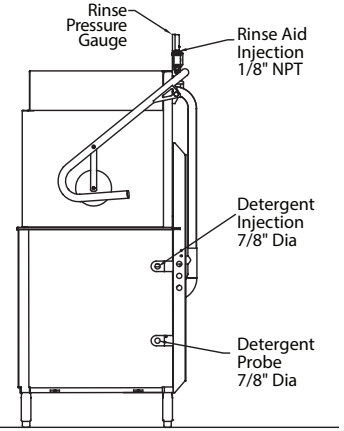

Side View

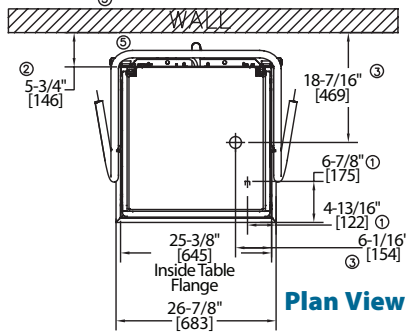

Plan View

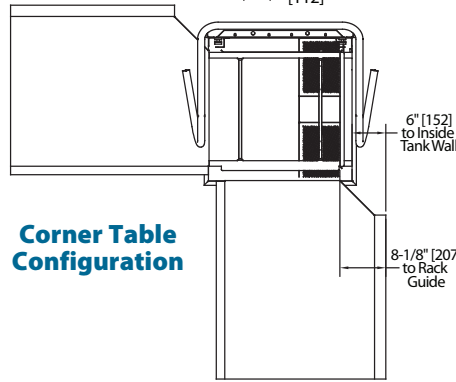

Corner Table Configuration

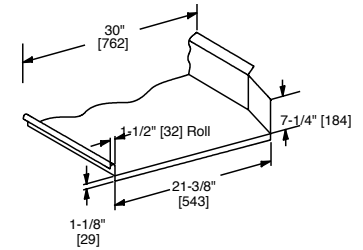

Typical Table Construction

## UTILITIES

- Electrical** Machine Connection (See Electrical Box)
- Hot Water** 3/4" NPT Hot Water 110° - 140°F 45 PSI dynamic min. incoming Final rinse 18 PSI
- Drain** 1" NPT Connection Gravity flow, 15 GPM max flow
- Drain Water Tempering** 1/2" Cold water line with customer supplied cut-off valve (optional)
- Integrated Detergent System** Detergent bottle supply connections (optional)

**Warning:** Plumbing, electrical connections should be made by qualified personnel who will observe all the applicable plumbing, sanitary and safety codes and the National Electrical Code.

**Note:** Optional Drain Tempering: 1/2" NPT cold water connection required. 1/2" NPT drain connection from back flow preventer to house drain. (FIELD INSTALLED and PLUMBED). Due to an ongoing value analysis program at Champion, specifications contained in this catalog are subject to change without notice.

Champion Industries, Inc.,  
3765 Champion Blvd., NC 27105  
336/661-1556 • Fax: 336/661-1979  
ChampionIndustries.com

Machine & Built-in Booster (Standard)			
Voltage	Rated Amps	Minimum Supply Circuit Ampacity	Maximum Overcurrent Protective Device
208-240/60/1	77-68	100	100
208-240/60/3	46-41	60	60
480/60/3	20	30	30

Machine Only (two point electrical connection or no built-in booster)			
Voltage	Rated Amps	Minimum Supply Circuit Ampacity	Maximum Overcurrent Protective Device
208-240/60/1	38-34	50	50
208-240/60/3	25-23	30	30
480/60/3	11	15	15

Booster Only (two point electrical connection)			
Voltage	Rated Amps	Minimum Supply Circuit Ampacity	Maximum Overcurrent Protective Device
208-240/60/1	39-34	50	50
208-240/60/3	21-18	25	25
480/60/3	9	15	15

**Note:** Water Hammer Arrestor (meeting ASSE-1010 standard or equivalent) to be supplied (by others) in common water supply line at service connection. Recommended water hardness to be 3 grains or less for optimal performance results.

## SPECIFICATIONS

- Capacities**  
Racks per hr. (NSF rated) 60  
Wash tank (gal.) 10
- Motor horsepower** 2 HP
- Water consumption**  
Gal. per hr. (max. use) 39  
Gal. per rack 0.73
- Temperature °F**  
Wash 150  
Rinse 180
- Heating**  
Tank heat, electric 5.2 kW  
Electric Booster 7.5 kW

Selectable cycle times in minutes	Dish-washer Mode		Pot & Pan Mode	
	1	2	4	6
<b>Time cycles in seconds</b>				
Wash	36	94	214	334
Rinse	8	10	10	10
Sanitary Dwell	16	16	16	16
<b>Total</b>	<b>60</b>	<b>120</b>	<b>240</b>	<b>360</b>