

Champion®

The Dishwashing Machine Specialists

Project _____
 Item No. _____
 Quantity _____

UH-200B UNDERCOUNTER

STANDARD FEATURES

- **ENERGY STAR® Qualified**
- **NEW "Shear Energy"** – a reduction in energy requirements while maximizing performance!
- **NEW "Multi-Phase"** – allows for infield conversion from single to three phase electrical with ease!
- **Rinse Sentry** – extends the cycle time to ensure 180°F/82°C final rinse.
- **Built-in electric booster** for 180°F/82°C final rinse water (standard 40°F/22°C or optional 70°F/39°C rise)
- Pumped drain
- Soft start wash pump
- Low-water tank heat protection
- Detergent and rinse aid pumps
- Quiet double-wall construction
- Door safety switch
- Independent stainless steel interchangeable upper and lower wash and rinse arms
- Fresh water rinse
- Top mounted slide-out controls
- Stainless steel top and side panels
- 90-second total cycle time
- Extended wash for difficult ware cleaning & de-liming
- Automatic drain cycle
- 1 Hp motor
- Digital thermometer
- Stainless steel construction

UH-200B

Undercounter High Temperature Dishwashing Machine with Built-in Booster Heater

UH-200 Model without Booster Heater



SPECIFIER STATEMENT

Specified unit will be Champion model UH-200B undercounter high temperature dishwashing machine with built-in booster heater.

Features 90 second total cycle, extended wash, LED temp display, Rinse Sentry, rinse aid and detergent pumps, flexible fill and drain hoses, stainless steel top and side panels. Constructed of stainless steel.

1 year parts and labor warranty.

OPTIONS & ACCESSORIES

1-RDT Dish Table Durable, heavy-gauge stainless steel dish table with sink, stand-pipe drain, removable scrap screen holder, drain-board, backsplash and lower storage cabinet. Sprayhose is optional. See 1-RDT catalog sheet. Specify right hand or left hand sink.

Additional Dish Racks

17" Stand
Stainless Steel

6" Leg Stand

3 Phase Connection (prewired at factory)

70°F/39°C Rise Booster

UH-200 without Booster

1" Roller Kit (includes 4 casters)

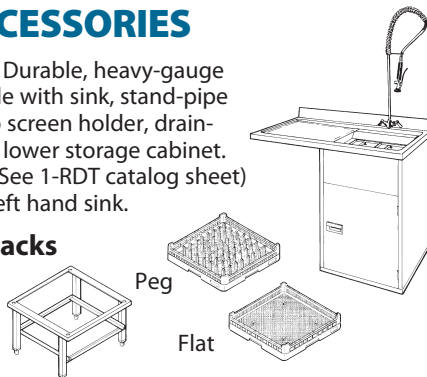

CH085

Champion Industries, Inc.
 3765 Champion Blvd, Winston-Salem, NC 27105
 Tel: 336/661-1556 Fax: 336/661-1979

www.championindustries.com



UH-200B

Undercounter High Temperature Dishwashing Machine with Built-in Booster Heater

Champion®

The Dishwashing Machine Specialists

Dimensions shown in inches and [millimeters]

Volume crated: **15 cu. ft./0.42 cu.m.**
 Shipping weight crated: **215 lbs./97.5 kg.**

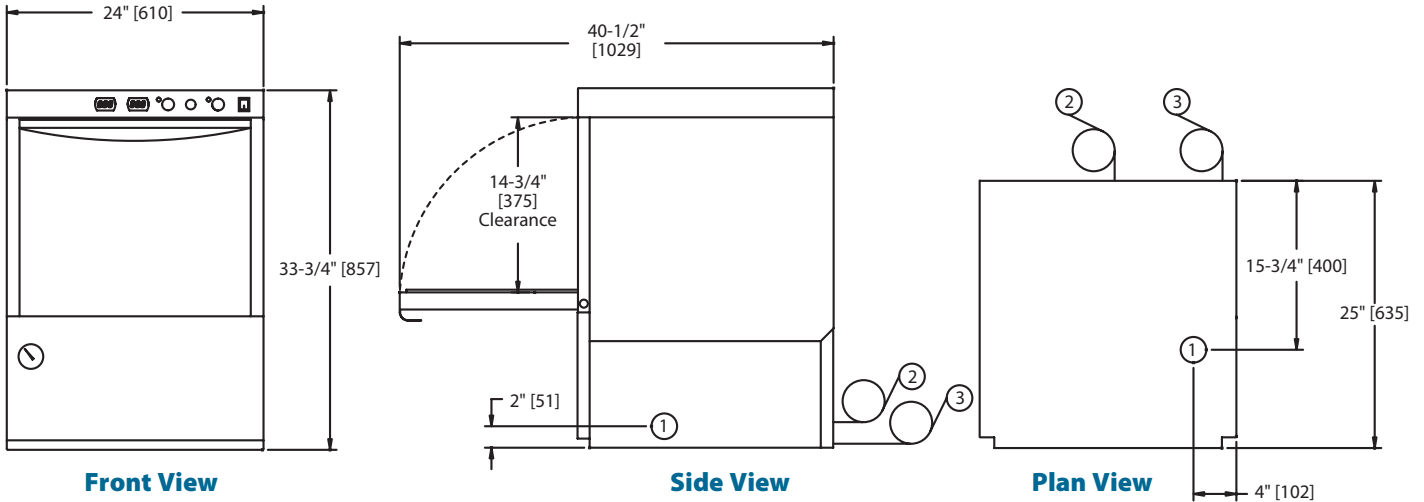

Utilities	
1	Electrical 208-240/60/1; 3 wire plus ground, (See Box). 208-240/60/3; 4 wire plus ground, (See Box). Field convertible to accept 3 phase power, see service manual for details
2	Hot Water 1/2" supply; 140°F/60°C Min. hot water connection for 40°F/22°C rise booster; 110°F/43°C Min. hot water connection for 70°F/39°C rise booster. Incoming supply pressure must maintain a Flow pressure of 20-22 PSI (Pressure reducing valve, PRV, supplied by customer or may be purchased unmounted from Champion). Machine equipped with 3/4" [19] hose connector.
3	Pumped Drain 5/8" [15.9] I.D. flexible reinforced hose, 6 ft. [1829] long. Max. drain flow 15 US gpm. [12.5 imp gal] Max. drain height 3 ft. [914]

SPECIFICATIONS

Capacities	
Cycle time (seconds)	90
Racks per hr. (NSF)	30
Motor horsepower	
Wash	1
Water consumption	
U.S. Gal./Imperial Gal. (Max. use) per hr.	28.2/23.2
U.S. Gal./Imperial Gal. per rack	.9/.75
Temperatures °F/°C	
Wash	150/66
Rinse	180/82
Heating	
Tank heat, electric, kW	2.0
Electric booster (kW) required for 40°F/22°C rise	6
Electric booster (kW) required for 70°F/39°C rise	9
Time Cycle in Seconds	
Wash	70
Rinse	15
Total cycle	90
Standard 20" x 20" [508 x 508] Rack Complement	
Dish	1
Open	1

UH-200B with 40°F/22°C Rise Booster

Elec. Specs.	Rated Amps	Minimum Supply Ckt. Conductor Ampacity	Maximum Overcurrent Protective Device
208/60/1	32	40	40
240/60/1	36	40	40
208/60/3	22	30	30
240/60/3	24	30	30

UH-200B with 70°F/39°C Rise Booster

Elec. Specs.	Rated Amps	Minimum Supply Ckt. Conductor Ampacity	Maximum Overcurrent Protective Device
208/60/1	45	60	60
240/60/1	50	60	60
208/60/3	29	35	35
240/60/3	33	40	40

Field convertible to accept 3 phase power

Warning Plumbing and electrical connections should be made by qualified personnel who will observe all the applicable plumbing, sanitary and safety codes and the National Electrical Code.

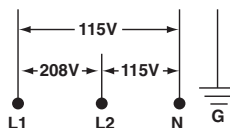

Note: Electrical supply service must be a 3-wire plus ground for connection shown.

UH-200 without booster 750 Watt tank heat	
Elec. Specs.	Rated Amps
115/60/1	12

Due to an ongoing value analysis program at Champion, specification contained in this catalog are subject to change without notice.

Champion Industries, Inc., 3765 Champion Blvd, Winston-Salem, NC 27105 • 336/661-1556 • Fax: 336/661-1979 • www.championindustries.com
 2674 N. Service Road, Jordan Station, Ontario, Canada L0R 1S0 • 800/263-5798 • Fax: 905/562-4618