



ITEM #: _____ QTY: _____
 MODEL #: _____
 PROJECT NAME: _____

050218

3601 S. Banker St. Effingham, IL 62401 • P.O. BOX 609 • Ph: (888) 431-2667 • Fax: (800) 433-2667

“CUCIC” CUCINA MAGNIFICO

FEATURES:

- NORTHERN HARD ROCK MAPLE EDGE GRAIN TOP WITH VARNIQUE FINISH
- FOOD SERVICE GRADE STAINLESS STEEL SHELF
- DOVETAILED DRAWERS
- STAINLESS STEEL TOWEL BAR
- ELECTRICAL OUTLET STRIP
- COMMERCIAL GRADE 5" LOCKING CASTERS
- SHIPPED SET-UP, 1 CARTON



CUCIC04

CUCINA MAGNIFICO

MODEL #	QTY
CUCIC04	

DETAILED SPECIFICATIONS

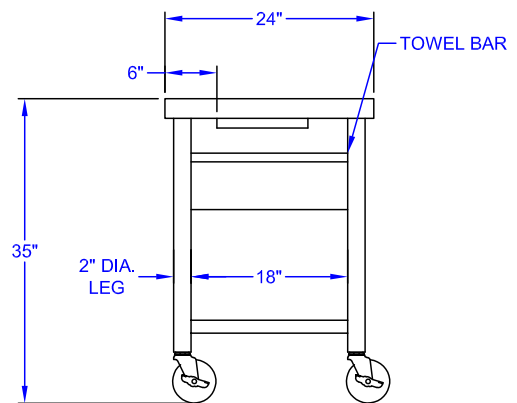
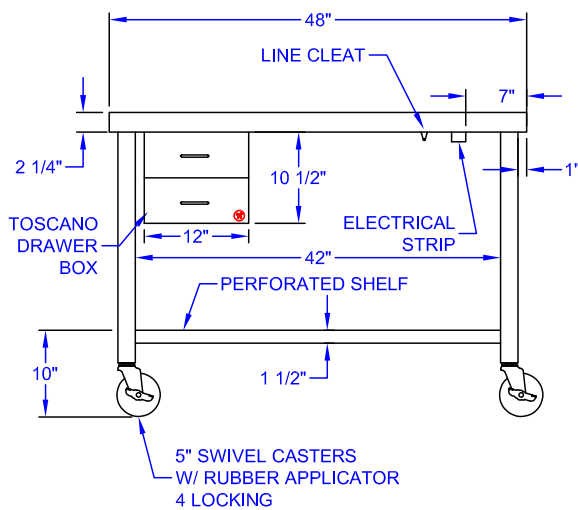
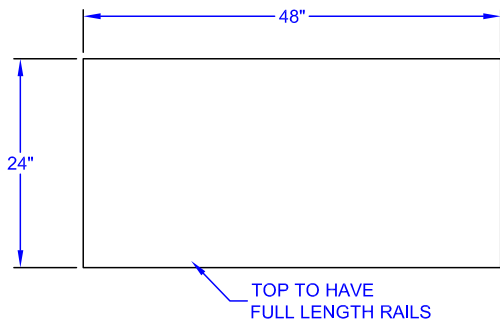

CUCINA MAGNIFICO

MODEL #	SIZE	HEIGHT	WEIGHT (LBS)
CUCIC04	48" X 24" X 2-1/4"	35"	200

SOME UNITS SHIP UNASSEMBLED FOR REDUCED SHIPPING COST. ALL DIMENSIONS ARE TYPICAL. TOLERANCE +/- .500"
John Boos & Co. is constantly engaged in a program of improving products and therefore reserves the right to change specifications without prior notice.



Boos
lock

AQ AutoQuotes

3601 S. Banker St. • Effingham, IL 62401 • PO BOX 609 • quotes@johnboos.com

www.johnboos.com

030918

243