

ATMOVAC

A COMPLETE RANGE OF SOUS-VIDE COOKING SOLUTIONS

SOFTCOOKERXP 120
SOFTCOOKERXP 230

MADE IN ITALY

THERMAL IMMERSION CIRCULATORS FOR SOUS-VIDE

With volume capacity from 25 liters (6.6 gallons) to 60 liters per unit (15.6 gallons) our ATMOVAC units will deliver precise temperature control over time in all conditions.

- Precise temperature and time control
- Adapts to a variety of containers.
- Sous-Vide cooking or Precise Rethermalization in Cook and Chill processes
- Perform pasteurization processes for maximum shelf life and sale opportunity
- No direct contact with air or water extends life of foods and provides maximum safety
- Save on energy consumption compared to oven or gas stove



**ALSO AVAILABLE
FROM ATMOVAC**



SV-96
MADE IN CHINA



SV-120
MADE IN CHINA



SV-310
MADE IN CHINA



Please consult our website www.eurodib.com for additional information on our product lines.
US 334 Cornelia St., Suite #272, Plattsburgh, NY 12901 | CAN 120 rue de la Barre, Boucherville, QC, J4B 2X7
1 888 956 6866 | info@eurodib.com | www.eurodib.com

ATMOVAC

	SOFTCOOKERXP 120	SOFTCOOKERXP 230
POWER	120V, 1500W, 12A	220V, 2000W, 9A
NEMA	5-15P	6-15P
MINIMUM WATER LEVEL	3.75"	
MAXIMUM WATER LEVEL	6"	
MAXIMUM VOLUME CAPACITY	11 Gal (43L)	
TIMER RANGE	1 - 99 hours	
TEMPERATURE RANGE	24 - 99°C	
	75 - 210°F	
TEMPERATURE VARIANCE (+/-)	.03°C	
	.03°F	
AUTO SHUT-OFF	YES	
DIMENSIONS (L X W X H)	10.25" x 5" x 15"	
NET WEIGHT	10 lbs	
SHIPPING DIMENSIONS (L X W X H)	13" x 9.5" x 18"	
SHIPPING WEIGHT	12 lbs	

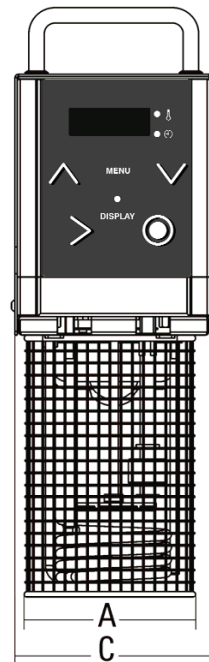

A 4.3"
B 4"
C 5"
D 10.25"
E 6.7"
F 6.7"
G 8.25"

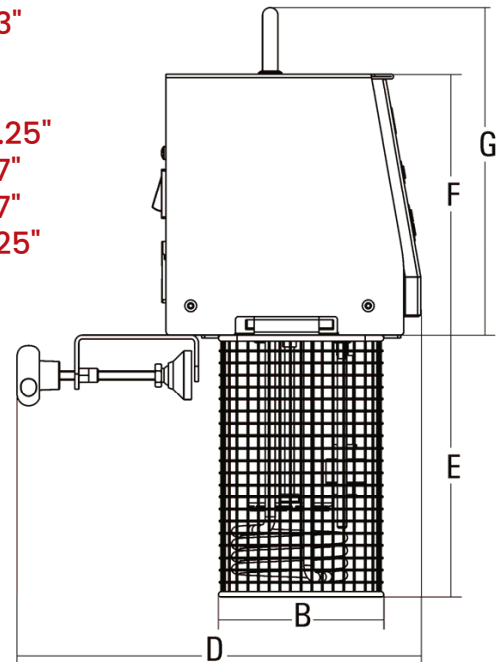

FEATURES:

- **Heavy-duty AISI 304 stainless steel construction**
- Temperature and time controls
- Working temperature display
- 25 adjustable preset cooking programs
- Delayed start
- Adjustable fixed clamp
- Electro-polished coated spiral element
- Plastic coated stainless steel handle for convenience

SAFETY FEATURE:

- Dry-Run Protection
- Element protective cell
- Protection against overvoltage and overheating

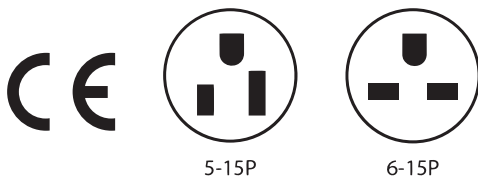

5-15P

6-15P

V3.12.2021