

COMBITHERM® COMBINATION OVEN/STEAMER

INSTALLATION MANUAL

CT PROFORMANCE™

CTP6-10E	CTP6-10G
CTP10-10E	CTP10-10G
CTP7-20E	CTP7-20G
CTP10-20E	CTP10-20G
CTP20-10E	CTP20-10G
CTP20-20E	CTP20-20G

CT CLASSIC™

CTC6-10E	CTC6-10G
CTC10-10E	CTC10-10G
CTC7-20E	CTC7-20G
CTC10-20E	CTC10-20G
CTC20-10E	CTC20-10G
CTC20-20E	CTC20-20G

⚠ WARNING
To prevent personal injury, death or property damage:
Do not store or use gasoline or other flammable vapors or liquids in the vicinity of this or any other appliance.

⚠ WARNING
Improper installation, alteration, adjustment, service, cleaning, or maintenance could result in property damage, severe injury, or death.
Read and understand the installation, operating and maintenance instructions thoroughly before installing, servicing, or operating this equipment.





All Alto-Shaam equipment is sold Free on Board (F.O.B.) shipping point, and when accepted by the carrier, such shipments become the property of the consignee.

Should damage occur in shipment, do not put the appliance into service until the damage has been inspected by an authorized Alto-Shaam service provider.

Shipping damages are a matter between the carrier and the consignee. In such cases, the carrier is assumed to be responsible for the safe delivery of the merchandise, unless negligence can be established on the part of the shipper.

1. Make an immediate inspection while the appliance is still in the truck or immediately after it is moved to the receiving area. Do not wait until after the appliance is moved to a storage area.
2. Do not sign a delivery receipt or a freight bill until a proper count has been made and inspection of all appliances are received.

3. Note all damage to packages directly on the carrier's delivery receipt.
4. Make certain the driver signs the delivery receipt. If the driver refuses to sign, make a notation of this refusal on the receipt.
5. If the driver refuses to allow inspection, write the following on the delivery receipt: **Driver refuses to allow inspection of containers for visible damage.**
6. Contact the carrier's office immediately upon finding damage, and request an inspection. Mail a written confirmation to the carrier's office with the time, date, and the person called.
7. Save any packages and packing material for further inspection by the carrier.
8. Promptly file a written claim with the carrier and attach copies of all supporting paperwork.

Alto-Shaam will continue our policy of assisting our customers in collecting claims which have been properly filed and actively pursued. Alto-Shaam cannot, however, file any damage claims, assume the responsibility of any claims, or accept deductions in payment for such claims.

Record the model and serial number of the appliance for easy reference. Always refer to both model and serial number in any contact with Alto-Shaam regarding this appliance.

Model: _____

Serial Number: _____

Date Installed: _____

Voltage: _____

Purchased From: _____



Alto-Shaam has established a twenty-four hour emergency service call center to offer immediate customer access to a local authorized service agency outside of standard business hours. The emergency service access is provided exclusively for Alto-Shaam equipment and is available throughout the United States through the use of Alto-Shaam's toll-free number. Emergency service access is available seven days a week including holidays.

Delivery

This Alto-Shaam appliance has been thoroughly tested and inspected to ensure only the highest quality unit is provided. Upon receipt, check for any possible shipping damage and report it at once to the delivering carrier. **See Transportation Damage and Claims section located in this manual.**

This appliance, complete with unattached items and accessories, may be delivered in one or more packages. Ensure all standard items and options have been received with each model as ordered.

Save all the information packed with the appliance. Register online at www.alto-shaam.com to ensure prompt service in the event of a warranty parts and labor claim.

This manual must be read and understood by all people using or installing the equipment model. Contact the Alto-Shaam Tech Team Service Department if you have any questions concerning installation, operation, or maintenance.

1-800-558-8744; servicedept@alto-shaam.com

The serial number is required for all inquiries.

Always include both model and serial number(s) in any correspondence regarding the appliance.

Model: _____

Serial number: _____

Purchased from: _____

Date installed: _____ Voltage: _____

Unpacking

- Carefully remove the appliance from the carton or crate.

NOTICE: Do not discard the carton and other packaging material until you have inspected the unit for hidden damage and tested it for proper operation.

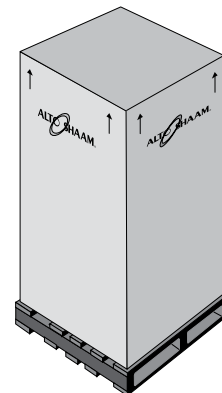

- Read all instructions in this manual carefully before installing this appliance, using the appliance or performing routine maintenance. Following procedures other than those indicated in this guide to use and clean the appliance is considered inappropriate and may cause damage, injury or fatal accidents, in addition to invalidating the guarantee and relieving Alto-Shaam of all liability.
- DO NOT DISCARD THIS MANUAL.** This manual is considered part of the appliance and is provided for the owner or manager of the business and for training personnel. **Additional manuals are available from the Alto-Shaam Tech Team Service Department.**
- Remove all protective plastic film, packaging materials, and accessories from the appliance before connecting electrical power. Store any accessories in a convenient place for future use.



CAUTION



Appliance and accessories may be heavy. To prevent serious injury, **always** use a sufficient number of trained and experienced workers when moving or leveling appliance and handling accessories.

ENVIRONMENTAL CONDITIONS

- Operational Environmental Conditions
- Unit must acclimate to room temperature in the environment it is placed. 24 hours is recommended.
- Ambient temperature range of 60°F to 110°F (16°C to 43°C).
- Relative humidity of less than 95% non-condensation.
- Atmospheric pressure range of 50KPa to 106KPa.

This manual covers the following CTC and CTP series models:

Control Type		Boiler-Free Models	Steam Generator Models
CTP	CT PROformance™ with PROtouch™ control	6-10E, 6-10G 10-10E, 10-10G	6-10EB 10-10EB
CTC	CT Classic with Classic manual control	7-20E, 7-20G 10-20E, 10-20G 20-10E, 20-10G 20-20E, 20-20G	7-20EB 10-20EB 20-10EB 20-20EB

Please post the following instructions in a prominent location in the event the user smells gas.

DANGER	
	<p>Before starting the appliance, make certain you do not detect the odor of gas.</p> <p>If you smell gas:</p> <ul style="list-style-type: none"> • Shut off the gas supply immediately. • Do not attempt to light any appliance. • Do not touch any electrical elements. • Extinguish any open flame. • Evacuate the area. • Use a telephone outside the property and immediately contact your gas supplier. • If unable to contact your gas supplier, contact the fire department.

Transportation Damage and Claims	2	Ventilation Requirements for Gas Models	45
Delivery	3	Gas Supply & Installation	46
Safety Procedures and Precautions	6	Water Quality Requirements	51
Installation	8	Water Supply & Installation	52
Site Installation	8	Water Drainage – For Single Oven	53
Installation Codes and Standards	8	Water Drainage – For Stacked Ovens	54
Ventilation Requirements	8	Mobile Equipment Restraint	55
Sound Pressure Measurements	8	For Gas Models	55
Installation Duties & Responsibilities		For Electric Models	55
– New Construction	9	CombiHood PLUS™ Ventless Hood Option	56
Installation Duties & Responsibilities		Grease Collection Installation	
– Retrofit/Existing Kitchen	10	(If Equipped With This Option)	57
Factory Authorized Installation Program		Liquid Cleaner Hook-Up (If Equipped with this Option)	58
Pre-Installation Checklist	11	CT PROformance™ Start-Up Procedures	59
CTP6-10G Spec Sheet	14	How To Turn On the Appliance	59
CTC6-10G Spec Sheet	15	How To Start a Manual Calibration	59
CTP10-10G Spec Sheet	16	How To Calibrate the Touch Screen	59
CTC10-10G Spec Sheet	17	How To Turn Off the Appliance	59
CTP7-20G Spec Sheet	18	How To Run a Cycle Test of the Appliance	60
CTC7-20G Spec Sheet	19	CT Classic™ Start-Up Procedures	61
CTP10-20G Spec Sheet	20	How To Turn On the Appliance	61
CTC10-20G Spec Sheet	21	How To Preheat the Appliance	61
CTP20-10G Spec Sheet	22	Factory Authorized Installation Program	
CTC20-10G Spec Sheet	23	Post-Installation Checklist	62
CTP20-20G Spec Sheet	24	Factory Authorized Installation Program	
CTC20-20G Spec Sheet	25	Function Test Checklist	64
CTP6-10E Spec Sheet	26	Daily Inspection Checklist	66
CTC6-10E Spec Sheet	27	Weekly Inspection Checklist	67
CTP10-10E Spec Sheet	28	Monthly Inspection Checklist	68
CTC10-10E Spec Sheet	29	Twelve-Month Inspection Checklist	69
CTP7-20E Spec Sheet	30	Troubleshooting	72
CTC7-20E Spec Sheet	31	Error Codes	72
CTP10-20E Spec Sheet	32	Touch Motor Control Error Codes	78
CTC10-20E Spec Sheet	33	Original Equipment Limited Warranty	79
CTP20-10E Spec Sheet	34		
CTC20-10E Spec Sheet	35		
CTP20-20E Spec Sheet	36		
CTC20-20E Spec Sheet	37		
Installation	38		
Lifting Instructions	38		
Positioning on Site – Countertop	39		
Positioning on Site – 20-10 & 20-20 Models	40		
Electrical Safety Regulations	41		
Electrical Connection for Gas Models	42		
Electrical Connection for Electric Models	42		
Electrical Kit Installation – 50 Hz	43		
Electrical Kit Installation – 60 Hz	44		

- This appliance is intended to cook, hold or process foods for the purpose of human consumption. No other use for this appliance is authorized and is therefore considered dangerous. The appliance must not be used to cook food containing flammable materials (such as food with alcohol). Substances with a low flash point can ignite spontaneously and cause a fire.
- This appliance is intended for use in commercial establishments where all operators are familiar with the purpose, limitations, and associated hazards of this appliance. Operating instructions and warnings must be read and understood by all operators and users. We recommend regular training of your staff to avoid the risk of accident or damage to the unit. Operators must also receive regular safety instructions.
- Any trouble shooting guides, component views, and parts lists included in this manual are for general reference only and are intended for use by qualified and trained technicians.
- This manual should be considered a permanent part of this appliance. This manual and all supplied instructions, diagrams, schematics, parts lists, notices, and labels must remain with the appliance if the item is sold or moved to another location.

Knowledge of proper procedures is essential to the safe operation of electrically and/or gas energized equipment. The following signal words and symbols may be used throughout this manual.

DANGER

Indicates a hazardous situation that, if not avoided, will result in death or serious injury.

WARNING

Indicates a hazardous situation that, if not avoided, could result in death or serious injury.

CAUTION

Indicates a hazardous situation that, if not avoided, could result in minor or moderate injury.

NOTICE: Indicates information considered important, but not hazard-related (e.g., messages relating to property damage).

NOTICE: For equipment delivered for use in any location regulated by the following directive: 2012/95/EC WEEE



DO NOT dispose of electrical or electronic equipment with other municipal waste.

- To prevent serious injury, death or property damage, your appliance should be inspected and serviced at least every twelve (12) months by an authorized service partner or trained technician.
- ONLY allow an authorized service partner or trained technician to service or to repair your appliance. Installation or repairs that are not performed by an authorized service partner or trained technician, or the use of non-factory authorized parts will void the warranty and relieve Alto-Shaam of all liability.
- When working on this appliance, observe precautions in the literature, on tags, on labels attached to or shipped with the appliance and other safety precautions that may apply.
- If the appliance is installed on casters freedom of movement of the appliance must be restricted so that utility connections (including gas, water, and electricity) cannot be damaged when the unit is moved. If the appliance is moved, make sure that all utility connections are properly disconnected. If the unit is returned to its original position, make sure that any retention devices and utility connections are properly connected.
- ONLY use the appliance when it is stationary. Mobile oven racks, mobile plate racks, transport trolleys, and appliances on casters can tip over when being moved over an uneven floor or threshold and cause serious injury.
- ALWAYS apply caster brakes on mobile appliances or accessories when these are not being moved. These items could move or roll on uneven floors and cause property damage or serious injury.
- Be extremely careful when moving appliances because the food trays may contain hot fluids that may spill, causing serious injury.
- ALWAYS open the appliance door very slowly. Escaping hot vapors or steam can cause serious injury or death.
- If your gas appliance is installed under an exhaust hood, the hood must be switched ON when the oven is in use to avoid the build up of combustion gases. Failure to do so may result in serious injury, death or property damage.
- NEVER place objects near the oven exhaust vents. This area is hot and could be a potential ignition source for a fire.
- Do not allow objects to block or obstruct the area below the oven base. This may result in fire, damage to the equipment or serious injury.
- Do not use the attached hand-held hose to spray anything other than the interior of the oven compartment.
- Do not use the attached hand-held hose on the surface of a hot cooking compartment. The sudden temperature change can damage the oven interior. Allow the oven to cool to a minimum of 150°F (66°C). Failure to observe this precaution can void the warranty.

WARNING



This appliance is not intended for use by persons (including children) with reduced physical, sensory or mental capabilities, or lack of experience and knowledge, unless they have been given supervision concerning use of the appliance by person responsible for their safety.

Children should be supervised to ensure that they do not play with the appliance.

WARNING



DO NOT obstruct or block exhaust flues or attach any flue extension that may impede proper burner operation, restrict the exhaust fumes and cause negative backdraft or the appliance to shut down. Failure to do so may result in serious injury or death.

SITE INSTALLATION

WARNING



Improper installation, alteration, adjustment, service, cleaning, or maintenance could result in property damage, severe injury, or death.

Read and understand the installation, operating and maintenance instructions thoroughly before installing, servicing, or operating this equipment.

INSTALLATION CODES & STANDARDS

The following codes and standards are required for installation of this oven:

AIR SUPPLY, ELECTRICAL CONNECTIONS, WATER CONNECTIONS, AND WASTE WATER DISCHARGE.

Installation shall comply with local codes required for gas appliances. In the absence of local codes, installation shall comply with the latest edition of:

- USA: National Fuel Gas Code, ANSI Z223.1 (NFPA 54). And OSHA Regulations
- Canada: Natural Gas and Propane Installation Code, CAN/CSA-B149.1-15
- EU: European Standard EN203
- Australia/New Zealand: AS 5601

Adherence to code by a qualified installer is essential for the following: gas plumbing, gas appliance installation, commercial cooking ventilation, water and plumbing.

WARNING



Electric shock hazard.

Perform lockout/tagout procedures before cleaning or servicing this appliance.

VENTILATION REQUIREMENTS

A steam ventilation hood is mandatory for the operation of the oven. In addition, a single gas Combitherm oven requires a minimum of 28 CFM make-up air for both natural and propane gas. Authorities having jurisdiction should be consulted as to the requirements for this equipment with respect to ventilation and fire extinguishing systems to ensure conformity with any Federal, State, or local installation codes.

See the section titled Gas Exhaust

SOUND PRESSURE MEASUREMENTS

The A-weighted sound pressure level without ventless hood operating is less than 70dBA.

NOTICE: ALWAYS remove the electronic control boards BEFORE welding any stainless steel components on this appliance. Failure to do so will damage the control boards and may void the warranty.

New Construction

Designer/Consultant Responsibilities: Pre-Installation	
	Complete water analysis to be conducted to ensure water quality meets manufacture specifications.
	Proper floor drain within 3' (914mm), not directly underneath, of where the appliance is to be installed.
	Minimum of one (1) 3/4" cold water supply line—two (2) recommended—with 3/4" shut off valve installed ahead of a minimum of two (2) 3/4" NPT connections.
	Gas appliances require one 3/4" line within 3' (914mm) of the appliance equipped with a manual shut off, and ready to be hooked to a 3/4" quick disconnect hose.
	Vent hood, and possible interconnection with gas supply as determined by local code.
	Proper electrical voltage, phase, wire size, breaker size, and disconnects are provided for hook ups within 3' (914mm) of the appliance.
	Exhaust air for gas appliances, exhaust hood, ventilation ceiling, chimney, spacing from top edge of appliance to lower edge of grease filters/ceiling.
	If floor is to be sloped then level surface must be provided for trolley/cart appliances.
	Confirm clearances of hallways, and doors to the installation area are sufficient for the model of the appliance being installed.
Installer Responsibilities: Pre-Installation	
	Pre-Installation check sheet has been properly filled out.
	Inspect, receive, deliver, uncrate, and set appliance in place.
Installer Responsibilities: Installation	
	Check that the appliance is level. Follow leveling instructions found in the installation manual.
	Make final water connections to both 3/4" cold water lines with required 30 psi minimum dynamic and 90 psi maximum static (2.1–6.3 bar) making sure treated and untreated are hooked up properly to the correct fittings.
	Hook up final electrical, check for proper voltage, phase, wire size, and breaker size. Ground fault or residual current protection device must accommodate a leakage current of 20mA. Report any issues to the designer / consultant.
	Plumb in the appliance drain per the required specifications found in the installation manual.
	Ensure gas pressure is above minimum and below maximum pressures listed in the installation manual for the corresponding gas type.
	Check that all accessories are unpackaged and set up for the end user.
	Ensure combi appliance is properly fastened to the ground, or has a restraint installed if on casters.
	Test that the CombiOven is fully operational, report any issues or manufacturing defects.
	Ensure most current software is installed.
	Pick up any packaging trash and debris from the installation.
	Clean and wipe down the outside of the appliance and make presentable to the end user.
	Take pictures of the installation verifying proper drain, water lines, and clearances are met.
ASA Responsibilities: After Install	
	Perform mechanical startup.
	Complete post installation check sheet.
	Pictures of the install's electrical connections, water, drain, and clearances should be taken and sent to: installation_program@alto-shaam.com
RSP/Dealer: After Install	
	Confirm installation is correct.
	Provide operational training and demonstration, and contact information for post installation support.
	Verify warranty registration documentation has been submitted.
Customer/End User	
	Complete and submit warranty registration documentation: www.alto-shaam.com/warranty
	Use the appliance only for its intended purpose.
	Follow cleaning and planned maintenance schedules to maximize the life of the equipment.

Retro Fit/Existing Kitchen

Designer/Consultant Responsibilities: Pre-Installation	
	Complete water analysis to be conducted to ensure water quality meets manufacture specifications.
	Proper floor drain within 3' (914mm), not directly underneath, of where the appliance is to be installed.
	Minimum of one (1) 3/4" cold water supply line—two (2) recommended—with 3/4" shut off valve installed ahead of a minimum of two (2) 3/4" NPT connections.
	Gas appliances require one 3/4" line within 3' (914mm) of the appliance equipped with a manual shut off, and ready to be hooked to a 3/4" quick disconnect hose.
	Proper vent hood is installed, and possible interconnection with gas supply per by local code.
	Proper electrical voltage, phase, wire size, breaker size, and disconnects are provided for hook ups within 3' (914mm) of the appliance.
	Exhaust air for gas appliances, exhaust hood, ventilation ceiling, chimney, spacing from top edge of appliance to lower edge of grease filters/ceiling.
	If floor is to be sloped then level surface must be provided for trolley/cart appliances.
	Confirm clearances of hallways, and doors to the installation area are sufficient for the model of the appliance being installed.
Installer Responsibilities: Pre-Installation	
	Pre-Installation check sheet has been properly filled out.
Installer Responsibilities: Installation	
	Inspect, receive, deliver, uncrate, set appliance in place, and check that appliance is level.
	Make final water connections to 3/4" cold water lines with required 30 psi minimum dynamic and 90 psi maximum static (2.1–6.3 bar) making sure treated and untreated are hooked up properly to the right fittings.
	Hook up final electrical, check for proper voltage, phase, wire size, and breaker size. Ground fault or residual current protection device must accommodate a leakage current of 20mA. Report any issues to the designer / consultant.
	Plumb in the appliance steam resistant drain per manufactures required specifications as found in the installation manual.
	Ensure gas pressure is above minimum and below maximum pressures listed in the installation manual for the corresponding gas type.
	Check that all accessories are unpackaged and set up for the end user.
	Ensure Combi appliance is properly fastened to the ground, or has a restraint installed if on casters.
	Ensure most current software is installed / uploaded.
	Verify installation meets the manufacture specifications per the installation manual.
	Test that the Combi appliance is fully operational, report any issues or manufacturing defects.
	Pick up any packaging trash and debris from the installation.
	Clean and wipe down the outside of the appliance and make presentable to the end user.
	Take pictures of the installation verifying proper drain, water lines, and clearances are met.
ASA Responsibilities: After Install	
	Perform mechanical startup.
	Complete post installation check sheet.
	Pictures of the install's electrical connections, water, drain, and clearances should be taken and sent to: installation_program@alto-shaam.com
RSP/Dealer: After Install	
	Confirm installation is correct.
	Provide operational training and demonstration, and contact information for post installation support.
	Verify warranty registration documentation has been submitted.
Customer/End User	
	Complete and submit warranty registration documentation.
	Use the appliance only for its intended purpose.
	Follow cleaning and planned maintenance schedules to maximize the life of the equipment.

Pre-Installation Checklist

Location Information	
Location Name: _____	Site Contact Name: _____
Location Street Address: _____	Site Contact Phone No.: _____
Location City: _____	Site Contact Email: _____
Location State: _____ Zip: _____	

Pre-Installation Company Information	
Company Name: _____	Technician Name: _____
Mailing Address: _____	Technician Phone No.: _____
City: _____	Contact Email: _____
State: _____ Zip: _____	Date of Site Survey: _____

Number of combis to be installed					
Model number(s) of combis to be installed					
Serial number of combi's to be installed					

Clearance					
Measure door/entry way clearance (smallest dimension)			PASS		FAIL
Measure path clearance (smallest dimension)			PASS		FAIL
Elevator opening, if applicable (smallest dimension)			PASS		FAIL
Elevator interior dimensions, if applicable (HxWxD)			PASS		FAIL
Appliance clearance	Right side		PASS		FAIL
	Left side		PASS		FAIL
	Rear		PASS		FAIL
	Top		PASS		FAIL
Based on the appliances designated spot in the kitchen, would the appliance be accessible for service?	YES			NO	
If NO, comment on the issue:					

Water Supply					
Is there at least one 3/4" cold water supply line within 3 feet of where each appliance will be installed?	PASS		FAIL: DESCRIBE ISSUE		
Do water supply line(s) have shut-off(s) exclusively for each oven?	PASS		FAIL: DESCRIBE ISSUE		
Do water supply line(s) provide a total two hookups per appliance, terminated with male NPT fittings?	PASS		FAIL: DESCRIBE ISSUE		
Is the dynamic water pressure from the 3/4" cold water supply line a minimum of 30 psi for each appliance?	PASS		FAIL		UNKNOWN
Is the static water pressure from the 3/4" cold water supply line less than 90 psi for each appliance?	PASS		FAIL		UNKNOWN
Is water treatment (RO blend system, filter, etc.) being used?	YES		NO		UNKNOWN
If YES - Note the system here:	BRAND NAME				MODEL
Can the site contact provide evidence that a documented water analysis has been performed?	YES			NO	

Pre-Installation Checklist

Electrical									
What is the rated voltage and phase of the oven(s) to be supplied?	VOLTAGE			PHASE					
What is the measured voltage at site?	L1-N		L2-N		L3-N		L1-L2		
	L2-3		L1-L3		PASS		FAIL		
What is the current draw of the oven(s) to be supplied?	AMP RATING								
What is the on-site breaker size supplying power to the oven(s)?	SIZE			PASS			FAIL		
Is there a disconnect or junction box within 3' (914mm) of where the oven(s) will be installed?	PASS		FAIL						
Comments:									
Gas									
What is the gas type for the oven(s) to be installed?	NATURAL			PROPANE					
What is the gas type confirmed at installation site?	NAT		PRO		PASS		FAIL		
Is there a minimum of one 3/4" gas supply line within 3' (914mm) of where the oven(s) will be installed?	PASS		FAIL						
On the gas line, is there a 3/4" NPT pipe connection with a shut-off valve within 3' (914mm) of where the oven(s) will be installed?	PASS		FAIL						
Comments:									
Drain									
Is there a floor drain within 3' (914mm) of where the oven(s) will be installed?	PASS		FAIL						
What is the actual distance to floor drain from where the oven(s) will be installed?	MEASUREMENT			PASS			FAIL		
Is the drain going to be located underneath the oven(s) that will be installed? (The drain should not be located directly under the oven — a No answer would = Pass)	PASS		FAIL						
Comments:									
Other site information									
Is there a proper ventilation hood installed above where the oven(s) will be installed?	PASS		FAIL						
Based on the designated location in the kitchen, is the floor level to the point that proper leveling of the oven(s) will be possible?	PASS		FAIL						
Is the site 100% ready for oven(s) installation?	PASS		FAIL						
Is site action required?	PASS		FAIL						
Take a photo of the following:									
<ul style="list-style-type: none"> The installation location One picture each of the utility connection points (drain, water, power, and gas) 									
Action Required:									
Comments:									

Please provide a copy of this document to an on-site manager.

Service company name:	
Service company number:	
Model of oven(s) to be installed:	
The site is ready for installation of the oven(s); planned install location passes inspection. Once the oven(s) arrive at the site (or the delivery date is certain), please contact the service company listed above to schedule the installation.	
The site is NOT ready for the installation of the oven(s); planned install location needs the following changes made before installation can proceed:	
On-site manager should make the necessary contacts to move forward with these changes as soon as possible. If there are any questions, please contact Alto-Shaam Technical Service Department at 800-558-8744 ext. 6702. Or, review documentation regarding the equipment www.alto-shaam.com/en/resource-library .	
Once the necessary site changes have been made and the oven(s) have arrived (or the delivery date is certain), please contact the service company listed above to schedule the installation.	
Technician name and signature:	
On-site manager name and signature:	

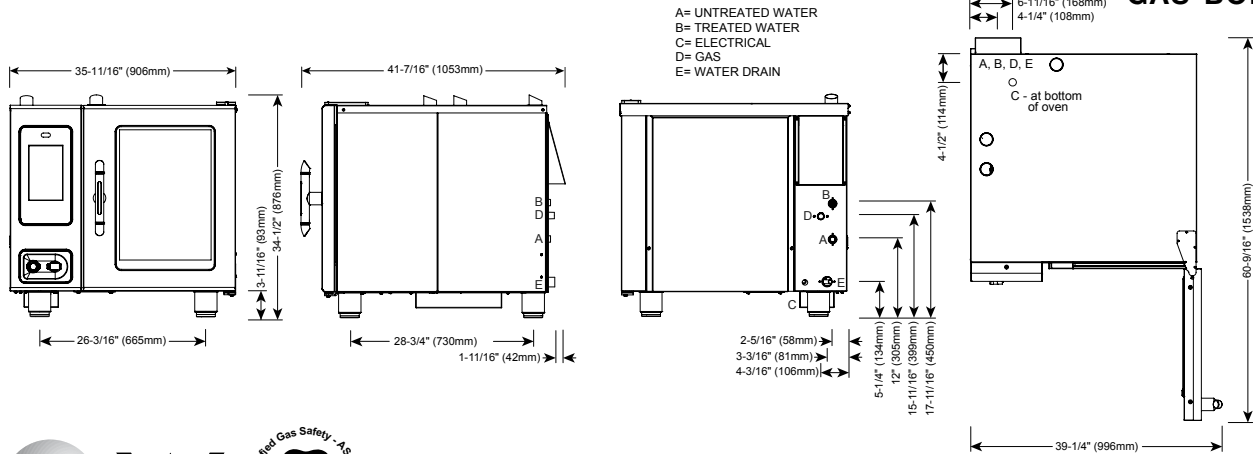

DIMENSIONS: H x W x D	
EXTERIOR:	34-1/2" x 35-11/16" x 41-7/16" (876mm x 906mm x 1053mm)
EXTERIOR WITH RECESSED DOOR:	34-1/2" x 40-11/16" x 41-7/16" (876mm x 1033mm x 1053mm)
INTERIOR:	20-1/2" x 16-1/4" x 28-1/16" (520mm x 411mm x 712mm)
WATER QUALITY STANDARDS	
It is the sole responsibility of the owner/operator/purchaser of this equipment to verify that the incoming water supply is comprehensively tested and if required, a means of "water treatment" provided that would meet compliance requirements with the published water quality standards shown below. Non-compliance with these minimum standards will potentially damage this equipment and/or components and void the original equipment manufacturer's warranty. Alto-Shaam recommends using OptiPure® [www.optipurewater.com] products to properly treat your water.	
Contaminant	Inlet Water Requirements
Free Chlorine	Less than 0.1 ppm (mg/L)
Hardness	30-70 ppm
Chloride	Less than 30 ppm (mg/L)
pH	7.0 to 8.5
Silica	Less than 12 ppm (mg/L)
Total Dissolved Solids (tds)	50-125 ppm

WATER REQUIREMENTS	
TWO (2) COLD WATER INLETS - DRINKING QUALITY	
ONE (1) TREATED WATER INLET: 3/4" NPT*	* Both inlets can be from same 3/4" source. Divide using a manifold. Run one side through treatment device before running to oven.
ONE (1) UNTREATED WATER INLET: 3/4" NPT*	
LINE PRESSURE: 30 psi minimum dynamic and 90 psi maximum static (200 to 600 kPa)	
WATER DRAIN: 1-1/2" (40mm) CONNECTION WITH A VERTICAL VENT TO EXTEND ABOVE THE EXHAUST VENT. MATERIALS MUST WITHSTAND TEMPERATURES UP TO 200°F (93°C).	
CLEARANCE REQUIREMENTS	
LEFT: 0" (0mm)	18" (457mm) RECOMMENDED SERVICE ACCESS
RIGHT: 0" (0mm) NON-COMBUSTIBLE SURFACES	2" (51mm) DOOR SWING OR COMBUSTIBLE SURFACES
TOP: 20" (508mm) FOR AIR MOVEMENT	
BACK: 4" (102mm)	BOTTOM: 5-1/8" (130mm) FOR LEGS, AIR INTAKE
INSTALLATION REQUIREMENTS	
• Oven must be installed level. • Hood installation is required.	
• Water supply shut-off valve and back-flow preventer when required by local code.	

GAS REQUIREMENTS (GAS TYPE MUST BE SPECIFIED ON ORDER)						HOOK-UP: 3/4" NPT							
UL Marked Appliances	Maximum Input BTU/h	Minimum Input BTU/h	Maximum Inlet Pressure Inches WC	Minimum Inlet Pressure Inches WC	Maximum Fuel Consumption*		AGA Marked Appliances	Maximum Input MJ/h	Minimum Input MJ/h	Maximum Inlet Pressure kPa	Minimum Inlet Pressure kPa	Maximum Fuel Consumption	
					CFH	GPH						m³/h	L/h
Natural Gas	48,000	32,000	14.0	5.5	45.7	N/A	Natural Gas	50.6	33.8	3.48	1.13	1.3	N/A
Propane				9.0	19.2	0.5						Propane	

*Assumes an average heating value for natural gas to be 1050 BTU/SCF and a specific gravity of 0.60. The assumed value for propane gas is 2,500 BTU/SCF, and a specific gravity of 1.53

CE Marked Appliances	Maximum Input		Minimum Input		Nominal Gas Pressure mbar	Maximum Gas Pressure mbar	Maximum Fuel Consumption m³
	kWh (Hs)	kWh (Hi)	kWh (Hs)	kWh (Hi)			
2E (G20)	14.1	12.7	12.5	11.3	50	1.3	
2LL (G25)							20
3P (G31)	13.8	12.7	12.2	11.3			1.6
3B/P (G30)							0.5
						0.5	

ELECTRICAL - CTP6-10G (DEDICATED CIRCUIT REQUIRED)								WITH COMBISMOKER® OPTION				
	VOLTAGE	PH	HZ	AWG (mm²)	CONNECTION no cord, no plug	AMPS	BREAKER	KW	CONNECTION no cord, no plug	AMPS	BREAKER	KW
☞	120	1	60	12 (3.31)	L1, L2/N, G	6.8	20	.84	L1, L2/N, G	12.0	20	1.5
☞☞	208-240	1*	50/60	14 (2.08)	L1, L2/N, G	4.8-4.2	15	1.0	L1, L2/N, G	7.3-7.1	15	1.5-1.7
☞☞☞	208-240	3	50/60	14 (2.08)	L1, L2, L3, G	4.8-4.2	15	1.0	L1, L2, L3, G	7.3-7.1	15	1.5-1.7
☞☞☞	380-415	3	50/60	14 (2.08)	L1, L2, L3, N, G	4.6-4.2	15	1.0	L1, L2, L3, N, G	7.2-7.1	15	1.6-1.7

☞ NORTH AMERICA VOLTAGE CHOICE ☞ GROUND FAULT OR RESIDUAL CURRENT PROTECTION DEVICE MUST ACCOMMODATE A LEAKAGE CURRENT OF 20mA ☞ INTERNATIONAL VOLTAGE CHOICE *ELECTRICAL SERVICE CHARGE APPLIES ▲ PER UL REQUIREMENTS, MUST BE PERMANENTLY CONNECTED TO ELECTRICAL SUPPLY SOURCE

WEIGHT		PAN CAPACITY		STANDARD MODEL		WITH COMBISMOKER® OPTION	
NET	524 lbs EST (238 kg)	FULL-SIZE:	20" x 12" x 2-1/2"	Seven (7)		Six (6)	
SHIP	590 lbs* (268 kg*)	GN 1/1:	530 x 325 x 65mm	Seven (7)		Six (6)	
		**HALF-SIZE SHEET:	18" x 13" x 1"	Seven (7)		Seven (7)	
SHIP DIMENSIONS				PRODUCT CAPACITY			
(L x W x H) 56" x 45" x 51"				PRODUCT MAXIMUM			
(1422mm x 1143mm x 1295mm)*				VOLUME MAXIMUM			
				72 lb (33 kg)			
				45 quarts (57 liters)			

*DOMESTIC GROUND SHIPPING INFORMATION. CONTACT FACTORY FOR EXPORT WEIGHT AND DIMENSIONS.

**ON WIRE SHELVES ONLY. ADDITIONAL WIRE SHELVES REQUIRED FOR MAXIMUM CAPACITY

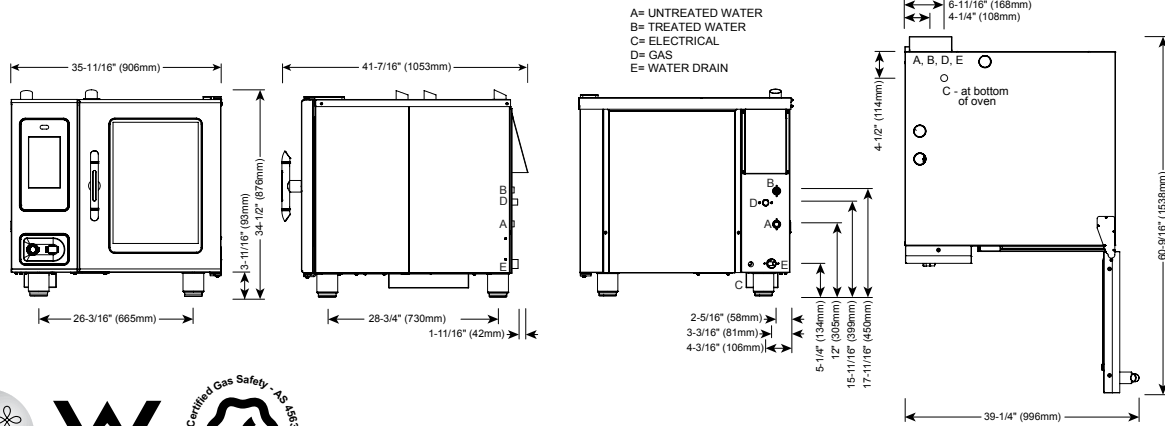

Global-Mark.com.au
© Number: GAG-10295-091



DIMENSIONS: H x W x D

EXTERIOR:

34-1/2" x 35-11/16" x 41-7/16" (876mm x 906mm x 1053mm)

EXTERIOR WITH RECESSED DOOR:

34-1/2" x 40-11/16" x 41-7/16" (876mm x 1033mm x 1053mm)

INTERIOR:

20-1/2" x 16-1/4" x 28-1/16" (520mm x 411mm x 712mm)

WATER REQUIREMENTS

TWO (2) COLD WATER INLETS - DRINKING QUALITY

ONE (1) TREATED WATER INLET: 3/4" NPT*
ONE (1) UNTREATED WATER INLET: 3/4" NPT*
 * Both inlets can be from same 3/4" source. Divide using a manifold. Run one side through treatment device before running to oven.
LINE PRESSURE: 30 psi minimum dynamic and 90 psi maximum static (200 to 600 kPa)
WATER DRAIN: 1-1/2" (40mm) CONNECTION WITH A VERTICAL VENT TO EXTEND ABOVE THE EXHAUST VENT. MATERIALS MUST WITHSTAND TEMPERATURES UP TO 200°F (93°C).

CLEARANCE REQUIREMENTS

LEFT: 0" (0mm)	18" (457mm) RECOMMENDED SERVICE ACCESS
RIGHT: 0" (0mm) NON-COMBUSTIBLE SURFACES	2" (51mm) DOOR SWING OR COMBUSTIBLE SURFACES
TOP: 20" (508mm) FOR AIR MOVEMENT	
BACK: 4" (102mm)	BOTTOM: 5-1/8" (130mm) FOR LEGS, AIR INTAKE
4-5/16" (109mm) OPTIONAL PLUMBING KIT	

INSTALLATION REQUIREMENTS

- Oven must be installed level.
- Hood installation is required.
- Water supply shut-off valve and back-flow preventer when required by local code.

WATER QUALITY STANDARDS

It is the sole responsibility of the owner/operator/purchaser of this equipment to verify that the incoming water supply is comprehensively tested and if required, a means of "water treatment" provided that would meet compliance requirements with the published water quality standards shown below. Non-compliance with these minimum standards will potentially damage this equipment and/or components and void the original equipment manufacturer's warranty. Alto-Shaam recommends using OptiPure® [www.optipurewater.com] products to properly treat your water.

Contaminant	Inlet Water Requirements
Free Chlorine	Less than 0.1 ppm (mg/L)
Hardness	30-70 ppm
Chloride	Less than 30 ppm (mg/L)
pH	7.0 to 8.5
Silica	Less than 12 ppm (mg/L)
Total Dissolved Solids (tds)	50-125 ppm

GAS REQUIREMENTS (GAS TYPE MUST BE SPECIFIED ON ORDER) HOOK-UP: 3/4" NPT

UL Marked Appliances	Maximum Input BTU/h	Minimum Input BTU/h	Maximum Inlet Pressure Inches WC	Minimum Inlet Pressure Inches WC		Maximum Fuel Consumption*		AGA Marked Appliances	Maximum Input MJ/h	Minimum Input MJ/h	Maximum Inlet Pressure kPa	Minimum Inlet Pressure kPa	Maximum Fuel Consumption	
				5.5	9.0	CFH	GPH						m³/h	L/h
Natural Gas	43,000	32,000	14.0	5.5	9.0	41.0	N/A	Natural Gas	45.4	33.8	3.48	1.13	1.2	N/A
Propane						17.2	0.5							

*Assumes an average heating value for natural gas to be 1050 BTU/SCF and a specific gravity of 0.60. The assumed value for propane gas is 2,500 BTU/SCF, and a specific gravity of 1.53

CE Marked Appliances	Maximum Input		Minimum Input		Nominal Gas Pressure mbar	Maximum Gas Pressure mbar	Maximum Fuel Consumption m³
	kWh (Hs)	kWh (Hi)	kWh (Hs)	kWh (Hi)			
2E (G20)					20	50	1.2
2LL (G25)	12.8	11.5	12.5	11.3	20		1.4
3P (G31)					37		0.5
3B/P (G30)	12.5	11.5	12.2	11.3	29		0.5

ELECTRICAL - CTC6-10G (DEDICATED CIRCUIT REQUIRED)

	VOLTAGE	PH	HZ	AWG (mm²)	CONNECTION	AMPS	BREAKER	kW
☉ ⚡	120	1	60	12 (3.31)	L1, L2/N, G - no cord, no plug	7.0	20	.84
☉ ⚡	208 - 240	3	50/60	14 (2.08)	L1, L2, L3, G - no cord, no plug	4.8 - 4.2	15	1.0
☉ ⚡	380 - 415	3	50/60	14 (2.08)	L1, L2, L3, N, G - no cord, no plug	4.6 - 4.2	15	1.0

☉ NORTH AMERICA VOLTAGE CHOICE ⚡ GROUND FAULT OR RESIDUAL CURRENT PROTECTION DEVICE MUST ACCOMMODATE A LEAKAGE CURRENT OF 20mA ☉ INTERNATIONAL VOLTAGE CHOICE

▲ PER UL REQUIREMENTS, MUST BE PERMANENTLY CONNECTED TO ELECTRICAL SUPPLY SOURCE

WEIGHT	SHIP DIMENSIONS	PAN CAPACITY
NET 524 lbs est (238 kg)	(L x W x H) 56" x 45" x 51"	FULL-SIZE: 20" x 12" x 2-1/2" Seven (7) PRODUCT MAXIMUM: 72 lb (33 kg)
SHIP 590 lbs* (268 kg*)	(1422 x 1143 x 1295mm)*	GN 1/1: 530 x 325 x 65mm Seven (7) VOLUME MAXIMUM: 45 quarts (57 liters)
		**HALF-SIZE SHEET: 18" x 13" x 1" Seven (7) **ON WIRE SHELVES ONLY. ADDITIONAL WIRE SHELVES REQUIRED FOR MAXIMUM CAPACITY

*DOMESTIC GROUND SHIPPING INFORMATION. CONTACT FACTORY FOR EXPORT WEIGHT AND DIMENSIONS.

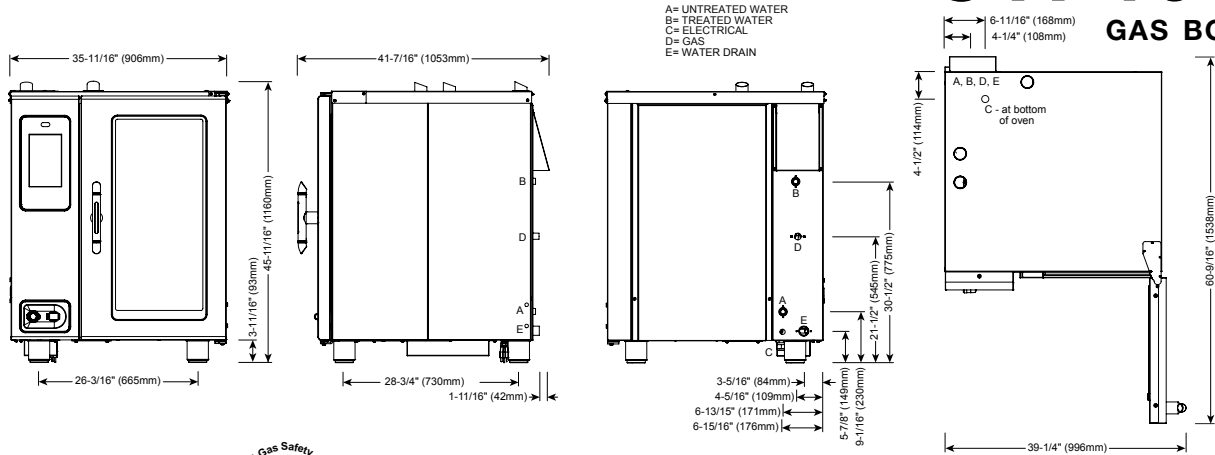

DIMENSIONS: H x W x D	
EXTERIOR: 45-11/16" x 35-11/16" x 41-7/16" (1160mm x 906mm x 1053mm)	
EXTERIOR WITH RECESSED DOOR: 45-11/16" x 40-11/16" x 41-7/16" (1160mm x 1033mm x 1053mm)	
INTERIOR: 31-1/2" x 16-1/4" x 28-1/16" (800mm x 411mm x 712mm)	
WATER QUALITY STANDARDS	
It is the sole responsibility of the owner/operator/purchaser of this equipment to verify that the incoming water supply is comprehensively tested and if required, a means of "water treatment" provided that would meet compliance requirements with the published water quality standards shown below. Non-compliance with these minimum standards will potentially damage this equipment and/or components and void the original equipment manufacturer's warranty. Alto-Shaam recommends using OptiPure® [www.optipurewater.com] products to properly treat your water.	
Contaminant	Inlet Water Requirements
Free Chlorine	Less than 0.1 ppm (mg/L)
Hardness	30-70 ppm
Chloride	Less than 30 ppm (mg/L)
pH	7.0 to 8.5
Silica	Less than 12 ppm (mg/L)
Total Dissolved Solids (tds)	50-125 ppm

WATER REQUIREMENTS	
TWO (2) COLD WATER INLETS - DRINKING QUALITY	
ONE (1) TREATED WATER INLET: 3/4" NPT*	* Both inlets can be from same 3/4" source. Divide using a manifold. Run one side through treatment device before running to oven.
ONE (1) UNTREATED WATER INLET: 3/4" NPT*	
LINE PRESSURE: 30 psi minimum dynamic and 90 psi maximum static (200 to 600 kPa)	
WATER DRAIN: 1-1/2" (40mm) CONNECTION WITH A VERTICAL VENT TO EXTEND ABOVE THE EXHAUST VENT. MATERIALS MUST WITHSTAND TEMPERATURES UP TO 200°F (93°C).	
CLEARANCE REQUIREMENTS	
LEFT: 0" (0mm)	18" (457mm) RECOMMENDED SERVICE ACCESS
RIGHT: 0" (0mm) NON-COMBUSTIBLE SURFACES	2" (51mm) DOOR SWING OR COMBUSTIBLE SURFACES
TOP: 20" (508mm) FOR AIR MOVEMENT	
BACK: 4" (102mm)	BOTTOM: 5-1/8" (130mm) FOR LEGS, AIR INTAKE
4-5/16" (109mm) OPTIONAL PLUMBING KIT	
INSTALLATION REQUIREMENTS	
• Oven must be installed level. • Hood installation is required.	
• Water supply shut-off valve and back-flow preventer when required by local code.	

GAS REQUIREMENTS (GAS TYPE MUST BE SPECIFIED ON ORDER) HOOK-UP: 3/4" NPT

UL Marked Appliances	Maximum Input BTU/h	Minimum Input BTU/h	Maximum Inlet Pressure Inches WC	Maximum Fuel Consumption*		AGA Marked Appliances	Maximum Input MJ/h	Minimum Input MJ/h	Maximum Inlet Pressure kPa	Minimum Inlet Pressure kPa	Maximum Fuel Consumption	
				CFH	GPH						m³/h	L/h
Natural Gas Propane	80,000	53,000	14.0	5.5	N/A	Natural Gas Propane	84.4	55.9	3.48	1.13	2.2	N/A
				9.0	0.9						2.75	0.9

*Assumes an average heating value for natural gas to be 1050 BTU/SCF and a specific gravity of 0.60. The assumed value for propane gas is 2,500 BTU/SCF, and a specific gravity of 1.53

CE Marked Appliances	Maximum Input		Minimum Input		Nominal Gas Pressure mbar	Maximum Gas Pressure mbar	Maximum Fuel Consumption m³
	kWh (Hs)	kWh (Hi)	kWh (Hs)	kWh (Hi)			
2E (G20)	23.3	21.0	15.5	14.0	50	2.2	
2LL (G25)							2.6
3P (G31)	22.8	21.0	15.5	14.3			0.9
3B/P (G30)							0.9

ELECTRICAL - CTP10-10G (DEDICATED CIRCUIT REQUIRED)									WITH COMBISMOKER® OPTION			
	VOLTAGE	PH	HZ	AWG (mm²)	CONNECTION no cord, no plug	AMPS	BREAKER	kW	CONNECTION no cord, no plug	AMPS	BREAKER	kW
☞☞▲	120	1	60	12 (3.31)	L1, L2/N, G	6.8	20	.84	L1, L2/N, G	12.0	20	1.5
☞☞▲	208 - 240	1*	50/60	14 (2.08)	L1, L2/N, G	4.8 - 4.2	15	1.0	L1, L2/N, G	7.3 - 7.1	15	1.5 - 1.7
☞☞▲	208 - 240	3	50/60	14 (2.08)	L1, L2, L3, G	4.8 - 4.2	15	1.0	L1, L2, L3, G	7.3 - 7.1	15	1.5 - 1.7
☞☞	380 - 415	3	50/60	14 (2.08)	L1, L2, L3, N, G	4.6 - 4.2	15	1.0	L1, L2, L3, N, G	7.2 - 7.1	15	1.6 - 1.7

NORTH AMERICA VOLTAGE CHOICE ☞☞ GROUND FAULT OR RESIDUAL CURRENT PROTECTION DEVICE MUST ACCOMMODATE A LEAKAGE CURRENT OF 20mA ☞☞ INTERNATIONAL VOLTAGE CHOICE *ELECTRICAL SERVICE CHARGE APPLIES PER UL REQUIREMENTS, MUST BE PERMANENTLY CONNECTED TO ELECTRICAL SUPPLY SOURCE

WEIGHT		PAN CAPACITY		STANDARD MODEL		WITH COMBISMOKER® OPTION	
NET	625 lbs EST (283 kg)	FULL-SIZE:	20" x 12" x 2-1/2"	Eleven (11)		Ten (10)	
SHIP	695 lbs* (315 kg*)	GN 1/1:	530 x 325 x 65mm	Eleven (11)		Ten (10)	
		**HALF-SIZE SHEET:	18" x 13" x 1"	Eleven (11)		Eleven (11)	
SHIP DIMENSIONS				PRODUCT CAPACITY			
(L x W x H) 56" x 45" x 65"				PRODUCT MAXIMUM		120 lb (54 kg)	
(1422mm x 1143mm x 1651mm)*				VOLUME MAXIMUM		75 quarts (95 liters)	

*DOMESTIC GROUND SHIPPING INFORMATION. CONTACT FACTORY FOR EXPORT WEIGHT AND DIMENSIONS.

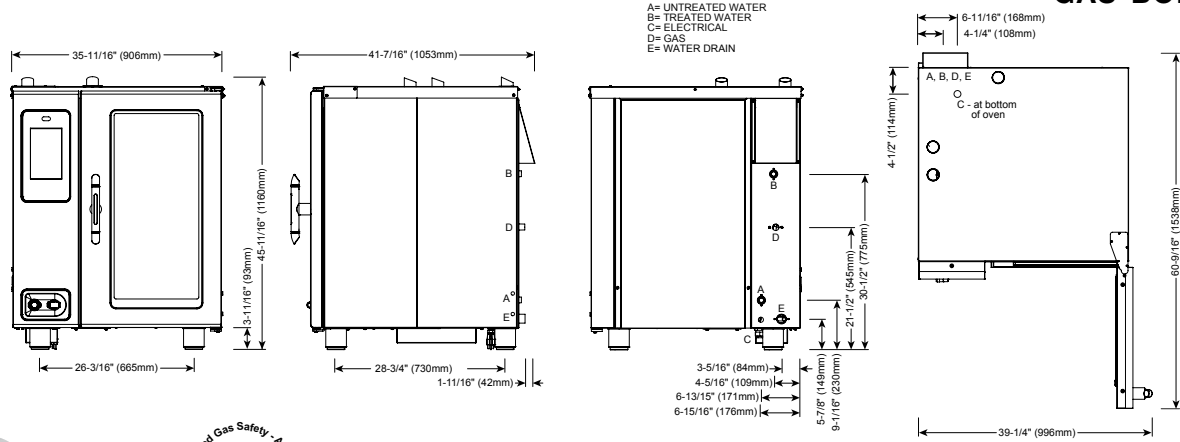

DIMENSIONS: H x W x D
EXTERIOR: 45-11/16" x 35-11/16" x 41-7/16" (1160mm x 906mm x 1053mm)
EXTERIOR WITH RECESSED DOOR: 45-11/16" x 40-11/16" x 41-7/16" (1160mm x 1033mm x 1053mm)
INTERIOR: 31-1/2" x 16-1/4" x 28-1/16" (800mm x 411mm x 712mm)

WATER REQUIREMENTS

TWO (2) COLD WATER INLETS - DRINKING QUALITY
ONE (1) TREATED WATER INLET: 3/4" NPT*
ONE (1) UNTREATED WATER INLET: 3/4" NPT*
LINE PRESSURE: 30 psi minimum dynamic and 90 psi maximum static (200 to 600 kPa)
WATER DRAIN: 1-1/2" (40mm) CONNECTION WITH A VERTICAL VENT TO EXTEND ABOVE THE EXHAUST VENT. MATERIALS MUST WITHSTAND TEMPERATURES UP TO 200°F (93°C).

WATER QUALITY STANDARDS

It is the sole responsibility of the owner/operator/purchaser of this equipment to verify that the incoming water supply is comprehensively tested and if required, a means of "water treatment" provided that would meet compliance requirements with the published water quality standards shown below. Non-compliance with these minimum standards will potentially damage this equipment and/or components and void the original equipment manufacturer's warranty. Alto-Shaam recommends using OptiPure® [www.optipurewater.com] products to properly treat your water.

Contaminant	Inlet Water Requirements
Free Chlorine	Less than 0.1 ppm (mg/L)
Hardness	30-70 ppm
Chloride	Less than 30 ppm (mg/L)
pH	7.0 to 8.5
Silica	Less than 12 ppm (mg/L)
Total Dissolved Solids (tds)	50-125 ppm

CLEARANCE REQUIREMENTS

LEFT: 0" (0mm)	18" (457mm) RECOMMENDED SERVICE ACCESS
RIGHT: 0" (0mm) NON-COMBUSTIBLE SURFACES	2" (51mm) DOOR SWING OR COMBUSTIBLE SURFACES
TOP: 20" (508mm) FOR AIR MOVEMENT	
BACK: 4" (102mm)	BOTTOM: 5-1/8" (130mm) FOR LEGS, AIR INTAKE

INSTALLATION REQUIREMENTS

- Oven must be installed level.
- Hood installation is required.
- Water supply shut-off valve and back-flow preventer when required by local code.

GAS REQUIREMENTS (GAS TYPE MUST BE SPECIFIED ON ORDER) HOOK-UP: 3/4" NPT

UL Marked Appliances	Maximum Input BTU/h	Minimum Input BTU/h	Maximum Inlet Pressure Inches WC	Minimum Inlet Pressure Inches WC	Maximum Fuel Consumption*		AGA Marked Appliances	Maximum Input MJ/h	Minimum Input MJ/h	Maximum Inlet Pressure kPa	Minimum Inlet Pressure kPa	Maximum Fuel Consumption	
					CFH	GPH						m³/h	L/h
Natural Gas Propane	70,000	53,000	14.0	5.5	66.7	N/A	Natural Gas Propane	73.9	55.9	3.48	1.13	2.0	N/A
				9.0	28.0	0.8					2.75	0.8	2.9

*Assumes an average heating value for natural gas to be 1050 BTU/SCF and a specific gravity of 0.60. The assumed value for propane gas is 2,500 BTU/SCF, and a specific gravity of 1.53

CE Marked Appliances	Maximum Input		Minimum Input		Nominal Gas Pressure mbar	Maximum Gas Pressure mbar	Maximum Fuel Consumption m³
	kWh (Gs)	kWh (Hi)	kWh (Gs)	kWh (Hi)			
2E (G20)	20.5	18.5	15.5	14.0	20	50	2.0
2LL (G25)					20		2.3
3P (G31)	20.1	18.5	15.5	14.3	37	50	0.8
3B/P (G30)					29		0.8

ELECTRICAL - CTC10-10G (DEDICATED CIRCUIT REQUIRED)

	VOLTAGE	PH	HZ	AWG (mm²)	CONNECTION	AMPS	BREAKER	kW
☞ ⚡	120	1	60	12 (3.31)	L1, L2/N, G - no cord, no plug	7	20	.84
☞ ⚡	208 - 240	3	50/60	14 (2.08)	L1, L2, L3, G - no cord, no plug	4.8 - 4.2	15	1.0
☞ ⚡	380 - 415	3	50/60	14 (2.08)	L1, L2, L3, N, G - no cord, no plug	4.6 - 4.2	15	1.0

☞ NORTH AMERICA VOLTAGE CHOICE ☞ GROUND FAULT OR RESIDUAL CURRENT PROTECTION DEVICE MUST ACCOMMODATE A LEAKAGE CURRENT OF 20mA ☞ INTERNATIONAL VOLTAGE CHOICE
 ▲ PER UL REQUIREMENTS, MUST BE PERMANENTLY CONNECTED TO ELECTRICAL SUPPLY SOURCE

WEIGHT	SHIP DIMENSIONS	PAN CAPACITY	PRODUCT MAXIMUM: 120 lb (54 kg)
NET	625 lbs est (283 kg)	FULL-SIZE: 20" x 12" x 2-1/2"	VOLUME MAXIMUM: 75 quarts (95 liters)
SHIP	695 lbs* (315 kg*)	GN 1/1: 530 x 325 x 65mm	
*DOMESTIC GROUND SHIPPING INFORMATION. CONTACT FACTORY FOR EXPORT WEIGHT AND DIMENSIONS.			**ON WIRE SHELVES ONLY. ADDITIONAL WIRE SHELVES REQUIRED FOR MAXIMUM CAPACITY

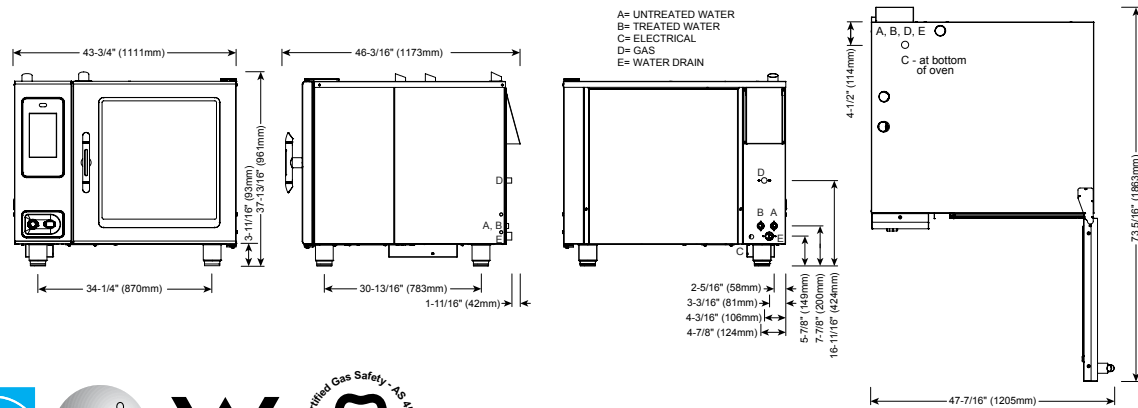

DIMENSIONS: H x W x D	
EXTERIOR: 37-13/16" x 43-3/4" x 46-3/16" (961mm x 1111mm x 1173mm)	
EXTERIOR WITH RECESSED DOOR: 37-13/16" x 48-3/4" x 46-3/16" (961mm x 1238mm x 1173mm)	
INTERIOR: 23-1/4" x 24-1/4" x 32-3/4" (590mm x 616mm x 832mm)	
WATER QUALITY STANDARDS	
It is the sole responsibility of the owner/operator/purchaser of this equipment to verify that the incoming water supply is comprehensively tested and if required, a means of "water treatment" provided that would meet compliance requirements with the published water quality standards shown below. Non-compliance with these minimum standards will potentially damage this equipment and/or components and void the original equipment manufacturer's warranty. Alto-Shaam recommends using OptiPure® [www.optipurewater.com] products to properly treat your water.	
Contaminant	Inlet Water Requirements
Free Chlorine	Less than 0.1 ppm (mg/L)
Hardness	30-70 ppm
Chloride	Less than 30 ppm (mg/L)
pH	7.0 to 8.5
Silica	Less than 12 ppm (mg/L)
Total Dissolved Solids (tds)	50-125 ppm

WATER REQUIREMENTS	
TWO (2) COLD WATER INLETS - DRINKING QUALITY	
ONE (1) TREATED WATER INLET: 3/4" NPT*	* Both inlets can be from same 3/4" source. Divide using a manifold. Run one side through treatment device before running to oven.
ONE (1) UNTREATED WATER INLET: 3/4" NPT*	
LINE PRESSURE: 30 psi minimum dynamic and 90 psi maximum static (200 to 600 kPa)	
WATER DRAIN: 1-1/2" (40mm) CONNECTION WITH A VERTICAL VENT TO EXTEND ABOVE THE EXHAUST VENT. MATERIALS MUST WITHSTAND TEMPERATURES UP TO 200°F (93°C).	
CLEARANCE REQUIREMENTS	
LEFT: 0" (0mm)	18" (457mm) RECOMMENDED SERVICE ACCESS
RIGHT: 0" (0mm) NON-COMBUSTIBLE SURFACES	2" (51mm) DOOR SWING OR COMBUSTIBLE SURFACES
TOP: 20" (508mm) FOR AIR MOVEMENT	
BACK: 4" (102mm)	BOTTOM: 5-1/8" (130mm) FOR LEGS, AIR INTAKE
4-5/16" (109mm) OPTIONAL PLUMBING KIT	
INSTALLATION REQUIREMENTS	
• Oven must be installed level. • Hood installation is required.	
• Water supply shut-off valve and back-flow preventer when required by local code.	

GAS REQUIREMENTS (GAS TYPE MUST BE SPECIFIED ON ORDER)				HOOK-UP: 3/4" NPT									
UL Marked Appliances	Maximum Input BTU/h	Minimum Input BTU/h	Maximum Inlet Pressure Inches WC	Maximum Fuel Consumption*		AGA Marked Appliances	Maximum Input MJ/h	Minimum Input MJ/h	Maximum Inlet Pressure kPa	Minimum Inlet Pressure kPa		Maximum Fuel Consumption	
				CFH	GPH					1.13	2.7	m³/h	LPH
Natural Gas	98,000	65,000	14.0	5.5	93.3	N/A							
Propane				9.0	39.2	1.1	103.4	68.6	3.48	2.75	1.1	4.1	

*Assumes an average heating value for natural gas to be 1050 BTU/SCF and a specific gravity of 0.60. The assumed value for propane gas is 2,500 BTU/SCF, and a specific gravity of 1.53

CE Marked Appliances	Maximum Input		Minimum Input		Nominal Gas Pressure mbar	Maximum Gas Pressure mbar	Maximum Fuel Consumption m³
	kWh (Hs)	kWh (Hi)	kWh (Hs)	kWh (Hi)			
2E (G20)					20	50	2.8
2LL (G25)	29.4	26.5	20.0	18.0	20		3.3
3P (G31)					37		1.1
3B/P (G30)	28.8	26.5	19.5	18.0	29		1.1

ELECTRICAL - CTP7-20G (DEDICATED CIRCUIT REQUIRED)								WITH COMBISMOKER® OPTION			
VOLTAGE	PH	HZ	AWG (mm²)	CONNECTION no cord, no plug	AMPS	BREAKER	KW	CONNECTION no cord, no plug	AMPS	BREAKER	KW
120	1	60	12 (3.31)	L1, N, G	6.8	20	.84	L1, N, G	12.0	20	1.5
208 - 240	1*	50/60	14 (2.08)	L1, L2/N, G	4.8 - 4.2	15	1.0	L1, L2/N, G	7.3 - 7.1	15	1.5 - 1.7
208 - 240	3	50/60	14 (2.08)	L1, L2, L3, G	4.8 - 4.2	15	1.0	L1, L2, L3, G	7.3 - 7.1	15	1.5 - 1.7
380 - 415	3	50/60	14 (2.08)	L1, L2, L3, N, G	4.6 - 4.2	15	1.0	L1, L2, L3, N, G	7.2 - 7.1	15	1.6 - 1.7

⚡ NORTH AMERICA VOLTAGE CHOICE ⚡ GROUND FAULT OR RESIDUAL CURRENT PROTECTION DEVICE MUST ACCOMMODATE A LEAKAGE CURRENT OF 20mA ⚡ INTERNATIONAL VOLTAGE CHOICE † ELECTRICAL SERVICE CHARGE APPLIES ▲ PER UL REQUIREMENTS, MUST BE PERMANENTLY CONNECTED TO ELECTRICAL SUPPLY SOURCE

WEIGHT		PAN CAPACITY		STANDARD MODEL		WITH COMBISMOKER® OPTION	
NET	660 lbs EST	300 kg	FULL-SIZE: 20" x 12" x 2-1/2" GN 1/1: 530 x 325 x 65mm GN 2/1: 650 x 530 x 65mm **FULL-SIZE SHEET: 18" x 26" x 1"	Sixteen (16)	Sixteen (16)	Fifteen (15)	Fifteen (15)
SHIP	728 lbs*	330 kg*		Eight (8)	Eight (8)	Seven (7)	Eight (8)
SHIP DIMENSIONS				PRODUCT CAPACITY			
(L x W x H) 56" x 49" x 51" (1422mm x 1245mm x 1295mm)*				PRODUCT MAXIMUM		168 lb (76 kg)	
				VOLUME MAXIMUM		105 quarts (133 liters)	

*DOMESTIC GROUND SHIPPING INFORMATION. CONTACT FACTORY FOR EXPORT WEIGHT AND DIMENSIONS. **ON WIRE SHELVES ONLY. ADDITIONAL WIRE SHELVES REQUIRED FOR MAXIMUM CAPACITY

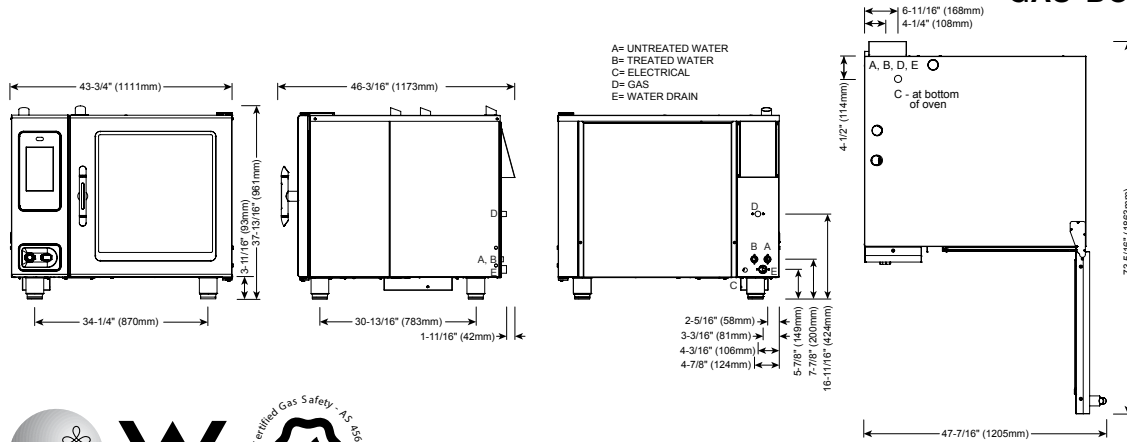

DIMENSIONS: H x W x D

EXTERIOR:
37-13/16" x 43-3/4" x 46-3/16" (961mm x 1111mm x 1173mm)

EXTERIOR WITH RECESSED DOOR:
37-13/16" x 48-3/4" x 46-3/16" (961mm x 1238mm x 1173mm)

INTERIOR:
23-1/4" x 24-1/4" x 32-3/4" (590mm x 616mm x 832mm)

WATER REQUIREMENTS

TWO (2) COLD WATER INLETS - DRINKING QUALITY

ONE (1) TREATED WATER INLET: 3/4" NPT*
ONE (1) UNTREATED WATER INLET: 3/4" NPT*
LINE PRESSURE: 30 psi minimum dynamic and 90 psi maximum static (200 to 600 kPa)
WATER DRAIN: 1-1/2" (40mm) CONNECTION WITH A VERTICAL VENT TO EXTEND ABOVE THE EXHAUST VENT. MATERIALS MUST WITHSTAND TEMPERATURES UP TO 200°F (93°C).

* Both inlets can be from same 3/4" source. Divide using a manifold. Run one side through treatment device before running to oven.

CLEARANCE REQUIREMENTS

LEFT: 0" (0mm)	18" (457mm) RECOMMENDED SERVICE ACCESS
RIGHT: 0" (0mm) NON-COMBUSTIBLE SURFACES	2" (51mm) DOOR SWING OR COMBUSTIBLE SURFACES
TOP: 20" (508mm) FOR AIR MOVEMENT	
BACK: 4" (102mm)	BOTTOM: 5-1/8" (130mm) FOR LEGS, AIR INTAKE
4-5/16" (109mm) OPTIONAL PLUMBING KIT	

INSTALLATION REQUIREMENTS

- Oven must be installed level.
- Hood installation is required.
- Water supply shut-off valve and back-flow preventer when required by local code.

WATER QUALITY STANDARDS

It is the sole responsibility of the owner/operator/purchaser of this equipment to verify that the incoming water supply is comprehensively tested and if required, a means of "water treatment" provided that would meet compliance requirements with the published water quality standards shown below. Non-compliance with these minimum standards will potentially damage this equipment and/or components and void the original equipment manufacturer's warranty. Alto-Shaam recommends using OptiPure® [www.optipurewater.com] products to properly treat your water.

Contaminant	Inlet Water Requirements
Free Chlorine	Less than 0.1 ppm (mg/L)
Hardness	30-70 ppm
Chloride	Less than 30 ppm (mg/L)
pH	7.0 to 8.5
Silica	Less than 12 ppm (mg/L)
Total Dissolved Solids (tds)	50-125 ppm

GAS REQUIREMENTS (GAS TYPE MUST BE SPECIFIED ON ORDER) HOOK-UP: 3/4" NPT

UL Marked Appliances	Maximum Input BTU/h	Minimum Input BTU/h	Maximum Inlet Pressure Inches WC	Minimum Inlet Pressure Inches WC	Maximum Fuel Consumption*		AGA Marked Appliances	Maximum Input MJ/h	Minimum Input MJ/h	Maximum Inlet Pressure kPa	Minimum Inlet Pressure kPa	Maximum Fuel Consumption	
					CFH	GPH						m³/h	L/h
Natural Gas Propane	85,000	65,000	14.0	5.5	81.0	N/A	Natural Gas Propane	89.7	68.6	3.48	1.13	2.4	N/A
				9.0	34.0	0.9						0.9	3.5

*Assumes an average heating value for natural gas to be 1050 BTU/SCF and a specific gravity of 0.60. The assumed value for propane gas is 2,500 BTU/SCF, and a specific gravity of 1.53

CE Marked Appliances	Maximum Input		Minimum Input		Nominal Gas Pressure mbar	Maximum Gas Pressure mbar	Maximum Fuel Consumption m³
	kWh (Hs)	kWh (Hi)	kWh (Hs)	kWh (Hi)			
2E (G20)	25.0	22.5	20.0	18.0	20	2.4	
2LL (G25)					20	2.8	
3P (G31)	24.5	22.5	19.5	18.0	37	0.9	
3B/P (G30)					29	0.9	

ELECTRICAL - CTC7-20G (DEDICATED CIRCUIT REQUIRED)

	VOLTAGE	PH	HZ	AWG (mm²)	CONNECTION	AMPS	BREAKER	kW
⚡	120	1	60	12 (3.31)	L1, L2/N, G - no cord, no plug	7.0	20	.84
⚡	208 - 240	3	50/60	14 (2.08)	L1, L2, L3, G - no cord, no plug	4.8 - 4.2	15	1.0
⚡	380 - 415	3	50/60	14 (2.08)	L1, L2, L3, N, G - no cord, no plug	4.6 - 4.2	15	1.0

⚡ NORTH AMERICA VOLTAGE CHOICE ⚡ GROUND FAULT OR RESIDUAL CURRENT PROTECTION DEVICE MUST ACCOMMODATE A LEAKAGE CURRENT OF 20mA ⚡ INTERNATIONAL VOLTAGE CHOICE
 ▲ PER UL REQUIREMENTS, MUST BE PERMANENTLY CONNECTED TO ELECTRICAL SUPPLY SOURCE

WEIGHT	SHIP DIMENSIONS	PAN CAPACITY
NET 660 lbs est 300 kg SHIP 728 lbs* 330 kg*	(L x W x H) 56" x 49" x 51"** (1422 x 1245 x 1295mm)*	FULL-SIZE: 20" x 12" x 2-1/2" GN 1/1: 530 x 325 x 65mm GN 2/1: 650 x 530 x 65mm **FULL-SIZE SHEET: 18" x 26" x 1"
*DOMESTIC GROUND SHIPPING INFORMATION. CONTACT FACTORY FOR EXPORT WEIGHT AND DIMENSIONS.		Sixteen (16) Sixteen (16) Eight (8) Eight (8)
		PRODUCT MAXIMUM: 168 lb (76 kg) VOLUME MAXIMUM: 105 quarts (133 liters) **ON WIRE SHELVES ONLY. ADDITIONAL WIRE SHELVES REQUIRED FOR MAXIMUM CAPACITY

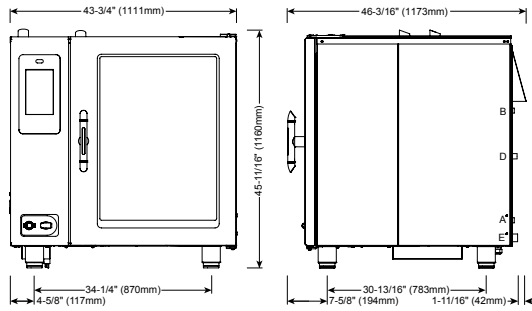

A= UNTREATED WATER
B= TREATED WATER
C= ELECTRICAL
D= GAS
E= WATER DRAIN

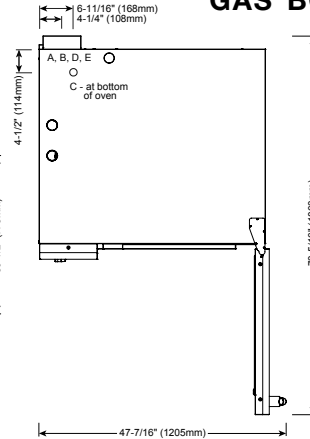

Global-Mark.com.au®
ID Number: GAS-10235-001



DIMENSIONS: H x W x D

EXTERIOR: 45-11/16" x 43-3/4" x 46-3/16" (1160mm x 1111mm x 1173mm)

EXTERIOR WITH RECESSED DOOR:
45-11/16" x 48-3/4" x 46-3/16" (1160mm x 1238mm x 1173mm)

INTERIOR: 31-1/2" x 24-1/4" x 32-3/4" (800mm x 616mm x 832mm)

WATER REQUIREMENTS

TWO (2) COLD WATER INLETS - DRINKING QUALITY

ONE (1) TREATED WATER INLET: 3/4" NPT*
ONE (1) UNTREATED WATER INLET: 3/4" NPT*
LINE PRESSURE: 30 psi minimum dynamic and 90 psi maximum static (200 to 600 kPa)
WATER DRAIN: 1-1/2" (40mm) CONNECTION WITH A VERTICAL VENT TO EXTEND ABOVE THE EXHAUST VENT. MATERIALS MUST WITHSTAND TEMPERATURES UP TO 200°F (93°C).

* Both inlets can be from same 3/4" source. Divide using a manifold. Run one side through treatment device before running to oven.

CLEARANCE REQUIREMENTS

LEFT: 0" (0mm)	18" (457mm) RECOMMENDED SERVICE ACCESS
RIGHT: 0" (0mm) NON-COMBUSTIBLE SURFACES	2" (51mm) DOOR SWING OR COMBUSTIBLE SURFACES
TOP: 20" (508mm) FOR AIR MOVEMENT	
BACK: 4" (102mm)	BOTTOM: 5-1/8" (130mm) FOR LEGS, AIR INTAKE

INSTALLATION REQUIREMENTS

- Oven must be installed level.
- Hood installation is required.
- Water supply shut-off valve and back-flow preventer when required by local code.

WATER QUALITY STANDARDS

It is the sole responsibility of the owner/operator/purchaser of this equipment to verify that the incoming water supply is comprehensively tested and if required, a means of "water treatment" provided that would meet compliance requirements with the published water quality standards shown below. Non-compliance with these minimum standards will potentially damage this equipment and/or components and void the original equipment manufacturer's warranty. Alto-Shaam recommends using OptiPure® [www.optipurewater.com] products to properly treat your water.

Contaminant	Inlet Water Requirements
Free Chlorine	Less than 0.1 ppm (mg/L)
Hardness	30-70 ppm
Chloride	Less than 30 ppm (mg/L)
pH	7.0 to 8.5
Silica	Less than 12 ppm (mg/L)
Total Dissolved Solids (tds)	50-125 ppm

GAS REQUIREMENTS (GAS TYPE MUST BE SPECIFIED ON ORDER) HOOK-UP: 3/4" NPT

UL Marked Appliances	Maximum Input BTU/h	Minimum Input BTU/h	Maximum Inlet Pressure Inches WC	Minimum Inlet Pressure Inches WC		Maximum Fuel Consumption*		AGA Marked Appliances	Maximum Input MJ/h	Minimum Input MJ/h	Maximum Inlet Pressure kPa	Minimum Inlet Pressure kPa		Maximum Fuel Consumption	
				5.5	9.0	CFH	GPH					1.13	2.75	m³/h	L/h
Natural Gas	133,000	89,000	14.0	5.5	9.0	126.7	N/A	Natural Gas	140.3	93.9	3.48	1.13	2.75	3.7	N/A
Propane						53.2	1.5	Propane						1.5	5.5

*Assumes an average heating value for natural gas to be 1050 BTU/SCF and a specific gravity of 0.60. The assumed value for propane gas is 2,500 BTU/SCF, and a specific gravity of 1.53

CE Marked Appliances	Maximum Input		Minimum Input		Nominal Gas Pressure mbar	Maximum Gas Pressure mbar	Maximum Fuel Consumption m³
	kWh (Hs)	kWh (Hi)	kWh (Hs)	kWh (Hi)			
2E (G20)					20	50	3.8
2LL (G25)	40.0	36.0	28.0	25.2	20		4.4
3P (G31)					37		1.5
3B/P (G30)	39.1	36.0	27.3	25.2			1.5

ELECTRICAL - CTP10-20G (DEDICATED CIRCUIT REQUIRED) WITH COMBISMOKER® OPTION

VOLTAGE	PH	HZ	AWG (mm²)	CONNECTION no cord, no plug	AMPS	BREAKER	kW	CONNECTION no cord, no plug	AMPS	BREAKER	kW
120	1	60	12 (3.31)	L1, N, G	6.8	20	.84	L1, N, G	12.0	20	1.5
208-240	1*	50/60	14 (2.08)	L1, L2/N, G	4.8-4.2	15	1.0	L1, L2/N, G	7.3-7.1	15	1.5-1.7
208-240	3	50/60	14 (2.08)	L1, L2, L3, G	4.8-4.2	15	1.0	L1, L2, L3, G	7.3-7.1	15	1.5-1.7
380-415	3	50/60	14 (2.08)	L1, L2, L3, N, G	4.6-4.2	15	1.0	L1, L2, L3, N, G	7.2-7.1	15	1.6-1.7

↻ NORTH AMERICA VOLTAGE CHOICE ↻ GROUND FAULT OR RESIDUAL CURRENT PROTECTION DEVICE MUST ACCOMMODATE A LEAKAGE CURRENT OF 20mA ↻ INTERNATIONAL VOLTAGE CHOICE † ELECTRICAL SERVICE CHARGE APPLIES ▲ PER UL REQUIREMENTS, MUST BE PERMANENTLY CONNECTED TO ELECTRICAL SUPPLY SOURCE

WEIGHT	PAN CAPACITY		STANDARD MODEL	WITH COMBISMOKER® OPTION
NET	760 lbs EST	345 kg	Twenty-two (22)	Twenty-one (21)
SHIP	930 lbs*	422 kg*	Twenty-two (22) Eleven (11) Eleven (11)	Twenty-one (21) Ten (10) Eleven (11)

SHIP DIMENSIONS	PRODUCT CAPACITY
(L x W x H) 56" x 49" x 65"	PRODUCT MAXIMUM
(1422mm x 1245mm x 1651mm)*	VOLUME MAXIMUM
	240 lb (109 kg)
	150 quarts (190 liters)

*DOMESTIC GROUND SHIPPING INFORMATION. CONTACT FACTORY FOR EXPORT WEIGHT AND DIMENSIONS. **ON WIRE SHELVES ONLY. ADDITIONAL WIRE SHELVES REQUIRED FOR MAXIMUM CAPACITY

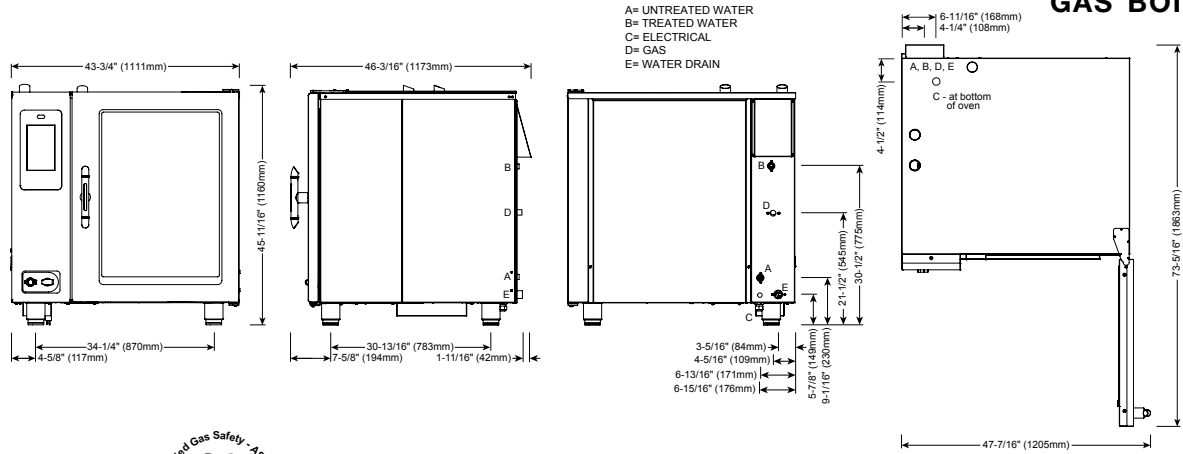

DIMENSIONS: H x W x D
EXTERIOR: 45-11/16" x 43-3/4" x 46-3/16" (1160mm x 1111mm x 1173mm)
EXTERIOR WITH RECESSED DOOR: 45-11/16" x 48-3/4" x 46-3/16" (1160mm x 1238mm x 1173mm)
INTERIOR: 31-1/2" x 24-1/4" x 32-3/4" (800mm x 616mm x 832mm)

WATER REQUIREMENTS	
TWO (2) COLD WATER INLETS - DRINKING QUALITY	
ONE (1) TREATED WATER INLET: 3/4" NPT*	* Both inlets can be from same 3/4" source. Divide using a manifold. Run one side through treatment device before running to oven.
ONE (1) UNTREATED WATER INLET: 3/4" NPT*	
LINE PRESSURE: 30 psi minimum dynamic and 90 psi maximum static (200 to 600 kPa)	
WATER DRAIN: 1-1/2" (40mm) CONNECTION WITH A VERTICAL VENT TO EXTEND ABOVE THE EXHAUST VENT. MATERIALS MUST WITHSTAND TEMPERATURES UP TO 200°F (93°C).	
CLEARANCE REQUIREMENTS	
LEFT: 0" (0mm)	18" (457mm) RECOMMENDED SERVICE ACCESS
RIGHT: 0" (0mm) NON-COMBUSTIBLE SURFACES	2" (51mm) DOOR SWING OR COMBUSTIBLE SURFACES
TOP: 20" (508mm) FOR AIR MOVEMENT	
BACK: 4" (102mm)	BOTTOM: 5-1/8" (130mm) FOR LEGS, AIR INTAKE
4-5/16" (109mm) OPTIONAL PLUMBING KIT	
INSTALLATION REQUIREMENTS	
• Oven must be installed level. • Hood installation is required.	
• Water supply shut-off valve and back-flow preventer when required by local code.	

WATER QUALITY STANDARDS	
It is the sole responsibility of the owner/operator/purchaser of this equipment to verify that the incoming water supply is comprehensively tested and if required, a means of "water treatment" provided that would meet compliance requirements with the published water quality standards shown below. Non-compliance with these minimum standards will potentially damage this equipment and/or components and void the original equipment manufacturer's warranty. Alto-Shaam recommends using OptiPure® [www.optipurewater.com] products to properly treat your water.	
Contaminant	Inlet Water Requirements
Free Chlorine	Less than 0.1 ppm (mg/L)
Hardness	30-70 ppm
Chloride	Less than 30 ppm (mg/L)
pH	7.0 to 8.5
Silica	Less than 12 ppm (mg/L)
Total Dissolved Solids (tds)	50-125 ppm

GAS REQUIREMENTS (GAS TYPE MUST BE SPECIFIED ON ORDER)						HOOK-UP: 3/4" NPT							
UL Marked Appliances	Maximum Input BTU/h	Minimum Input BTU/h	Maximum Inlet Pressure Inches WC	Minimum Inlet Pressure Inches WC	Maximum Fuel Consumption*		AGA Marked Appliances	Maximum Input MJ/h	Minimum Input MJ/h	Maximum Inlet Pressure kPa	Minimum Inlet Pressure kPa	Maximum Fuel Consumption	
					CFH	GPH						m³/h	L/h
Natural Gas	121,000	89,000	14.0	5.5	115.2	N/A	Natural Gas	127.7	93.9	3.48	1.13	3.4	N/A
Propane				9.0	48.4	1.3	Propane				2.75	1.3	5.0

*Assumes an average heating value for natural gas to be 1050 BTU/SCF and a specific gravity of 0.60. The assumed value for propane gas is 2,500 BTU/SCF, and a specific gravity of 1.53

CE Marked Appliances	Maximum Input		Minimum Input		Nominal Gas Pressure mbar	Maximum Gas Pressure mbar	Maximum Fuel Consumption m³
	kWh (Hs)	kWh (Hi)	kWh (Hs)	kWh (Hi)			
2E (G20)					20		3.4
2LL (G25)	35.5	32.0	28.0	25.2	20	50	3.9
3P (G31)					37		1.3
3B/P (G30)	34.8	32.0	27.3	25.2	29		1.3

ELECTRICAL - CTC10-20G (DEDICATED CIRCUIT REQUIRED)								
	VOLTAGE	PH	HZ	AWG (mm²)	CONNECTION	AMPS	BREAKER	KW
☉ ⚡	120	1	60	12 (3.31)	L1, L2/N, G - no cord, no plug	7.0	20	.84
☉ ⚡	208 - 240	3	50/60	14 (2.08)	L1, L2, L3, G - no cord, no plug	4.8 - 4.2	15	1.0
⚡	380 - 415	3	50/60	14 (2.08)	L1, L2, L3, N, G - no cord, no plug	4.6 - 4.2	15	1.0

☉ NORTH AMERICA VOLTAGE CHOICE ⚡ GROUND FAULT OR RESIDUAL CURRENT PROTECTION DEVICE MUST ACCOMMODATE A LEAKAGE CURRENT OF 20mA ⚡ INTERNATIONAL VOLTAGE CHOICE
▲ PER UL REQUIREMENTS, MUST BE PERMANENTLY CONNECTED TO ELECTRICAL SUPPLY SOURCE

WEIGHT	SHIP DIMENSIONS		PAN CAPACITY			PRODUCT MAXIMUM: 240 lb (109 kg)	
NET 760 lbs est 345 kg	(L x W x H) 56" x 49" x 65"*		FULL-SIZE:	20" x 12" x 2-1/2"	Twenty-two (22)	VOLUME MAXIMUM: 150 quarts (190 liters)	
SHIP 930 lbs* 422 kg*	(1422 x 1245 x 1651mm)*		GN 1/1:	530 x 325 x 65mm	Twenty-two (22)	**ON WIRE SHELVES ONLY. ADDITIONAL WIRE SHELVES REQUIRED FOR MAXIMUM CAPACITY	
*DOMESTIC GROUND SHIPPING INFORMATION. CONTACT FACTORY FOR EXPORT WEIGHT AND DIMENSIONS.			GN 2/1:	650 x 530 x 65mm	Eleven (11)		
			**FULL-SIZE SHEET:	18" x 26" x 1"	Eleven (11)		

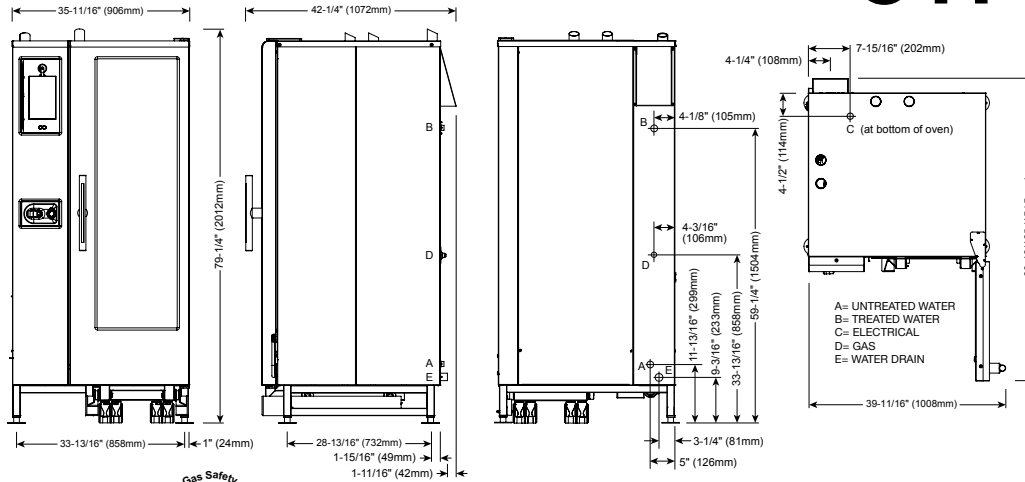

DIMENSIONS: H x W x D
EXTERIOR: 79-1/4" x 35-11/16" x 42-1/4" (2012mm x 906mm x 1072mm)
EXTERIOR WITH RECESSED DOOR: 79-1/4" x 40-11/16" x 42-1/4" (2012mm x 1033mm x 1072mm)
INTERIOR: 60-7/16" x 16-1/4" x 28-1/16" (1535mm x 411mm x 712mm)

WATER REQUIREMENTS

TWO (2) COLD WATER INLETS - DRINKING QUALITY
ONE (1) TREATED WATER INLET: 3/4" NPT*
ONE (1) UNTREATED WATER INLET: 3/4" NPT*
LINE PRESSURE: 30 psi minimum dynamic and 90 psi maximum static (200 to 600 kPa)
WATER DRAIN: 1-1/2" (40mm) CONNECTION WITH A VERTICAL VENT TO EXTEND ABOVE THE EXHAUST VENT. MATERIALS MUST WITHSTAND TEMPERATURES UP TO 200°F (93°C).

CLEARANCE REQUIREMENTS	
LEFT: 0" (0mm)	18" (457mm) RECOMMENDED SERVICE ACCESS
RIGHT: 0" (0mm) NON-COMBUSTIBLE SURFACES	2" (51mm) DOOR SWING OR COMBUSTIBLE SURFACES
TOP: 20" (508mm) FOR AIR MOVEMENT	
BACK: 4" (102mm)	BOTTOM: 5-1/8" (L30mm) FOR LEGS, AIR INTAKE
	4-5/16" (109mm) OPTIONAL PLUMBING KIT

INSTALLATION REQUIREMENTS
 • Oven must be installed level. • Hood installation is required.
 • Water supply shut-off valve and back-flow preventer when required by local code.

WATER QUALITY STANDARDS

It is the sole responsibility of the owner/operator/purchaser of this equipment to verify that the incoming water supply is comprehensively tested and if required, a means of "water treatment" provided that would meet compliance requirements with the published water quality standards shown below. Non-compliance with these minimum standards will potentially damage this equipment and/or components and void the original equipment manufacturer's warranty. Alto-Shaam recommends using OptiPure® [www.optipurewater.com] products to properly treat your water.

Contaminant	Inlet Water Requirements
Free Chlorine	Less than 0.1 ppm (mg/L)
Hardness	30-70 ppm
Chloride	Less than 30 ppm (mg/L)
pH	7.0 to 8.5
Silica	Less than 12 ppm (mg/L)
Total Dissolved Solids (tds)	50-125 ppm

GAS REQUIREMENTS (GAS TYPE MUST BE SPECIFIED ON ORDER) HOOK-UP: 3/4" NPT

UL Marked Appliances	Maximum Input BTU/h	Minimum Input BTU/h	Maximum Inlet Pressure Inches WC	Minimum Inlet Pressure Inches WC		Maximum Fuel Consumption*		AGA Marked Appliances	Maximum Input MJ/h	Minimum Input MJ/h	Maximum Inlet Pressure kPa	Minimum Inlet Pressure kPa	Maximum Fuel Consumption	
				5.5	9.0	CFH	GPH						m³/h	L/h
Natural Gas	160,000	107,000	14.0	5.5	9.0	152.4	N/A	Natural Gas	168.8	112.9	3.48	1.13	4.5	N/A
Propane						64.0	1.8	Propane				2.75	1.8	6.7

*Assumes an average heating value for natural gas to be 1050 BTU/SCF and a specific gravity of 0.60. The assumed value for propane gas is 2,500 BTU/SCF, and a specific gravity of 1.53

CE Marked Appliances	Maximum Input		Minimum Input		Nominal Gas Pressure mbar	Maximum Gas Pressure mbar	Maximum Fuel Consumption m³
	kWh (Hs)	kWh (Hi)	kWh (Hs)	kWh (Hi)			
2E (G20)	47.2	42.5	31.4	28.3	20	50	4.5
2LL (G25)					20		5.2
3P (G31)					37		1.7
3B/P (G30)	46.2	42.5	31.4	28.9	29		1.7

ELECTRICAL - CTP20-10G (DEDICATED CIRCUIT REQUIRED)									WITH COMBISMOKER® OPTION			
	VOLTAGE	PH	HZ	AWG (mm²)	CONNECTION no cord, no plug	AMPS	BREAKER	kW	CONNECTION no cord, no plug	AMPS	BREAKER	kW
☞☞☞	120	1	60	12 (3.31)	L1, L2/N, G	13.6	20	1.7	L1, L2/N, G	18.4	25	2.3
☞☞☞☞	208 - 240	1*	50/60	14 (2.08)	L1, L2/N, G	9.6 - 8.4	15	2.0	L1, L2/N, G	12.1 - 11.3	15	2.5 - 2.7
☞☞☞☞☞	208 - 240	3	50/60	14 (2.08)	L1, L2, L3, G	9.6 - 8.4	15	2.0	L1, L2, L3, G	12.1 - 11.3	15	2.5 - 2.7
☞☞☞☞☞☞	380 - 415	3	50/60	14 (2.08)	L1, L2, L3, N, G	9.2 - 8.4	15	2.0	L1, L2, L3, N, G	11.8 - 11.3	15	2.6 - 2.7

☞☞ NORTH AMERICA VOLTAGE CHOICE ☞☞ GROUND FAULT OR RESIDUAL CURRENT PROTECTION DEVICE MUST ACCOMMODATE A LEAKAGE CURRENT OF 20mA ☞☞ INTERNATIONAL VOLTAGE CHOICE *ELECTRICAL SERVICE CHARGE APPLIES ▲ PER UL REQUIREMENTS, MUST BE PERMANENTLY CONNECTED TO ELECTRICAL SUPPLY SOURCE

WEIGHT		SHIP DIMENSIONS		PAN CAPACITY			
NET	905 lbs est 411 kg	(L x W x H) 56" x 45" x 87"		FULL-SIZE:	20" x 12" x 2-1/2"	Twenty (20)	PRODUCT MAXIMUM: 240 lb (109 kg)
SHIP	1175 lbs* 533 kg*	(1422 x 1143 x 2210mm)*		GN 1/1:	530 x 325 x 65mm	Twenty (20)	VOLUME MAXIMUM: 150 quarts (190 liters)
*DOMESTIC GROUND SHIPPING INFORMATION. CONTACT FACTORY FOR EXPORT WEIGHT AND DIMENSIONS.				**HALF-SIZE SHEET:	18" x 13" x 1"	Twenty (20)	**ON WIRE SHELVES ONLY. ADDITIONAL WIRE SHELVES REQUIRED FOR MAXIMUM CAPACITY

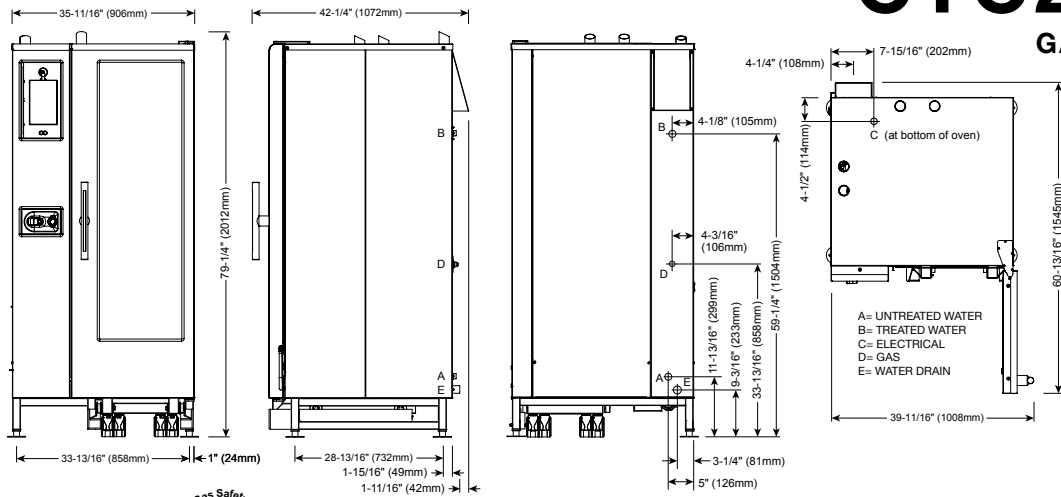

DIMENSIONS: H x W x D
EXTERIOR: 79-1/4" x 35-11/16" x 42-1/4" (2012mm x 906mm x 1072mm)
EXTERIOR WITH RECESSED DOOR: 79-1/4" x 40-11/16" x 42-1/4" (2012mm x 1033mm x 1072mm)
INTERIOR: 60-7/16" x 16-1/4" x 28-1/16" (1535mm x 411mm x 712mm)

WATER REQUIREMENTS	
TWO (2) COLD WATER INLETS - DRINKING QUALITY	
ONE (1) TREATED WATER INLET: 3/4" NPT*	*Both inlets can be from same 3/4" source. Divide using a manifold. Run one side through treatment device before running to oven.
ONE (1) UNTREATED WATER INLET: 3/4" NPT*	
LINE PRESSURE: 30 psi minimum dynamic and 90 psi maximum static (200 to 600 kPa)	
WATER DRAIN: 1-1/2" (40mm) CONNECTION WITH A VERTICAL VENT TO EXTEND ABOVE THE EXHAUST VENT. MATERIALS MUST WITHSTAND TEMPERATURES UP TO 200°F (93°C).	
CLEARANCE REQUIREMENTS	
LEFT: 0" (0mm)	18" (457mm) RECOMMENDED SERVICE ACCESS
RIGHT: 0" (0mm) NON-COMBUSTIBLE SURFACES	2" (51mm) DOOR SWING OR COMBUSTIBLE SURFACES
TOP: 20" (508mm) FOR AIR MOVEMENT	
BACK: 4" (102mm)	BOTTOM: 5-1/8" (130mm) FOR LEGS, AIR INTAKE
4-5/16" (109mm) OPTIONAL PLUMBING KIT	
INSTALLATION REQUIREMENTS	
• Oven must be installed level. • Hood installation is required.	
• Water supply shut-off valve and back-flow preventer when required by local code.	

WATER QUALITY STANDARDS	
It is the sole responsibility of the owner/operator/purchaser of this equipment to verify that the incoming water supply is comprehensively tested and if required, a means of "water treatment" provided that would meet compliance requirements with the published water quality standards shown below. Non-compliance with these minimum standards will potentially damage this equipment and/or components and void the original equipment manufacturer's warranty. Alto-Shaam recommends using OptiPure® [www.optipurewater.com] products to properly treat your water.	
Contaminant	Inlet Water Requirements
Free Chlorine	Less than 0.1 ppm (mg/L)
Hardness	30-70 ppm
Chloride	Less than 30 ppm (mg/L)
pH	7.0 to 8.5
Silica	Less than 12 ppm (mg/L)
Total Dissolved Solids (tds)	50-125 ppm

GAS REQUIREMENTS (GAS TYPE MUST BE SPECIFIED ON ORDER) HOOK-UP: 3/4" NPT

UL Marked Appliances	Maximum Input BTU/h	Minimum Input BTU/h	Maximum Inlet Pressure Inches WC	Minimum Inlet Pressure Inches WC		Maximum Fuel Consumption*		AGA Marked Appliances	Maximum Input MJ/h	Minimum Input MJ/h	Maximum Inlet Pressure kPa	Minimum Inlet Pressure kPa		Maximum Fuel Consumption	
				CFH	GPH	m³/h	L/h								
Natural Gas Propane	140,000	107,000	14.0	5.5	133.3	N/A	147.7	112.9	3.48	1.13	3.9	N/A			
				9.0	56.0	1.5				2.75	1.5	5.8			

*Assumes an average heating value for natural gas to be 1050 BTU/SCF and a specific gravity of 0.60. The assumed value for propane gas is 2,500 BTU/SCF, and a specific gravity of 1.53

CE Marked Appliances	Maximum Input		Minimum Input		Nominal Gas Pressure mbar	Maximum Gas Pressure mbar	Maximum Fuel Consumption m³
	kWh (Hs)	kWh (Hi)	kWh (Hs)	kWh (Hi)			
2E (G20)	41.1	37.0	31.4	28.3	20	3.9	
2LL (G25)					20	4.6	
3P (G31)	40.2	37.0	31.4	28.9	37	1.5	
3B/P (G30)					29	1.5	

ELECTRICAL - CTC20-10G (DEDICATED CIRCUIT REQUIRED)

	VOLTAGE	PH	HZ	AWG (mm²)	CONNECTION	AMPS	BREAKER	KW
☞	120	1	60	12 (3.31)	L1, L2/N, G - no cord, no plug	13.0	20	1.7
☞▲	208 - 240	3	50/60	14 (2.08)	L1, L2, L3, G - no cord, no plug	9.6 - 8.4	15	2.0
☞	380 - 415	3	50/60	14 (2.08)	L1, L2, L3, N, G - no cord, no plug	9.2 - 8.4	15	2.0

☞ NORTH AMERICA VOLTAGE CHOICE ☞ GROUND FAULT OR RESIDUAL CURRENT PROTECTION DEVICE MUST ACCOMMODATE A LEAKAGE CURRENT OF 20mA ☞ INTERNATIONAL VOLTAGE CHOICE ▲ PER UL REQUIREMENTS, MUST BE PERMANENTLY CONNECTED TO ELECTRICAL SUPPLY SOURCE

WEIGHT	SHIP DIMENSIONS	PAN CAPACITY	PRODUCT MAXIMUM:
NET 905 lbs est 411 kg	(L x W x H) 56" x 45" x 87"	FULL-SIZE: 20" x 12" x 2-1/2" Twenty (20)	240 lb (109 kg)
SHIP 1175 lbs* 533 kg*	(1422 x 1143 x 2210mm)*	GN 1/1: 530 x 325 x 65mm Twenty (20)	VOLUME MAXIMUM: 150 quarts (190 liters)
*DOMESTIC GROUND SHIPPING INFORMATION. CONTACT FACTORY FOR EXPORT WEIGHT AND DIMENSIONS.		**HALF-SIZE SHEET: 18" x 13" x 1" Twenty (20)	**ON WIRE SHELVES ONLY. ADDITIONAL WIRE SHELVES REQUIRED FOR MAXIMUM CAPACITY.

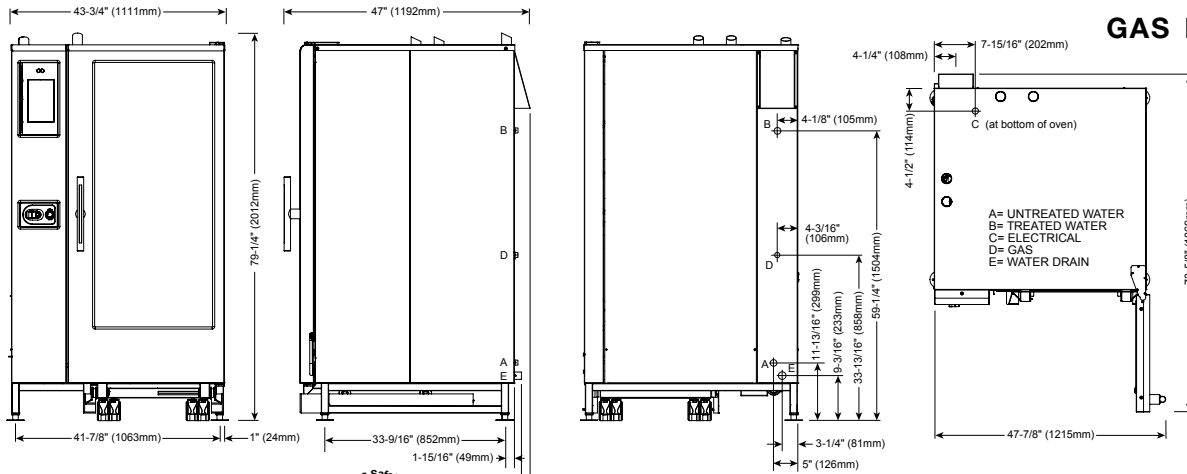

DIMENSIONS: H x W x D
EXTERIOR: 79-1/4" x 43-3/4" x 47" (2012mm x 1111mm x 1192mm)
EXTERIOR WITH RECESSED DOOR: 79-1/4" x 48-3/4" x 47" (2012mm x 1238mm x 1192mm)
INTERIOR: 60-7/16" x 24-1/4" x 32-3/4" (1535mm x 616mm x 832mm)

WATER REQUIREMENTS	
TWO (2) COLD WATER INLETS - DRINKING QUALITY	
ONE (1) TREATED WATER INLET: 3/4" NPT*	* Both inlets can be from same 3/4" source. Divide using a manifold. Run one side through treatment device before running to oven.
ONE (1) UNTREATED WATER INLET: 3/4" NPT*	
LINE PRESSURE: 30 psi minimum dynamic and 90 psi maximum static (200 to 600 kPa)	
WATER DRAIN: 1-1/2" (40mm) CONNECTION WITH A VERTICAL VENT TO EXTEND ABOVE THE EXHAUST VENT. MATERIALS MUST WITHSTAND TEMPERATURES UP TO 200°F (93°C).	
CLEARANCE REQUIREMENTS	
LEFT: 0" (0mm)	18" (457mm) RECOMMENDED SERVICE ACCESS
RIGHT: 0" (0mm) NON-COMBUSTIBLE SURFACES	2" (51mm) DOOR SWING OR COMBUSTIBLE SURFACES
TOP: 20" (508mm) FOR AIR MOVEMENT 4" (102mm)	
BACK: 4-5/16" (109mm) OPTIONAL PLUMBING KIT	BOTTOM: 5-1/8" (130mm) FOR LEGS, AIR INTAKE
INSTALLATION REQUIREMENTS	
• Oven must be installed level. • Hood installation is required.	
• Water supply shut-off valve and back-flow preventer when required by local code.	

WATER QUALITY STANDARDS	
It is the sole responsibility of the owner/operator/purchaser of this equipment to verify that the incoming water supply is comprehensively tested and if required, a means of "water treatment" provided that would meet compliance requirements with the published water quality standards shown below. Non-compliance with these minimum standards will potentially damage this equipment and/or components and void the original equipment manufacturer's warranty. Alto-Shaam recommends using OptiPure® [www.optipurewater.com] products to properly treat your water.	
Contaminant	Inlet Water Requirements
Free Chlorine	Less than 0.1 ppm (mg/L)
Hardness	30-70 ppm
Chloride	Less than 30 ppm (mg/L)
pH	7.0 to 8.5
Silica	Less than 12 ppm (mg/L)
Total Dissolved Solids (tds)	50-125 ppm

GAS REQUIREMENTS (GAS TYPE MUST BE SPECIFIED ON ORDER) HOOK-UP: 3/4" NPT

UL Marked Appliances	Maximum Input BTU/h	Minimum Input BTU/h	Maximum Inlet Pressure Inches WC	Minimum Inlet Pressure Inches WC	Maximum Fuel Consumption*		AGA Marked Appliances	Maximum Input MJ/h	Minimum Input MJ/h	Maximum Inlet Pressure kPa	Minimum Inlet Pressure kPa	Maximum Fuel Consumption	
					CFH	GPH						m³/h	LPH
Natural Gas Propane	266,000	177,000	14.0	5.5	253.3	N/A	Natural Gas Propane	280.6	186.7	3.48	1.13	7.4	N/A
				9.0	106.4	2.9					2.75	2.9	11.1

*Assumes an average heating value for natural gas to be 1050 BTU/SCF and a specific gravity of 0.60. The assumed value for propane gas is 2,500 BTU/SCF, and a specific gravity of 1.53

CE Marked Appliances	Maximum Input		Minimum Input		Nominal Gas Pressure mbar	Maximum Gas Pressure mbar	Maximum Fuel Consumption m³
	kWh (Hs)	kWh (Hi)	kWh (Hs)	kWh (Hi)			
2E (G20)	80.0	72.0	56.0	50.4	50	20	7.6
2LL (G25)						20	8.9
3P (G31)	78.3	72.0	54.6	50.4		37	2.9
3B/P (G30)						29	2.9

ELECTRICAL - CTP20-20G (DEDICATED CIRCUIT REQUIRED) WITH COMBISMOKER® OPTION

	VOLTAGE	PH	HZ	AWG (mm²)	CONNECTION no cord, no plug	AMPS	BREAKER	kW	CONNECTION no cord, no plug	AMPS	BREAKER	kW
☞☞☞▲	120	1	60	12 (3.31)	L1, L2/N, G	13.6	20	1.7	L1, L2/N, G	18.4	25	2.3
☞☞☞▲▲	208 - 240	1*	50/60	14 (2.08)	L1, L2/N, G	9.6 - 8.4	15	2.0	L1, L2/N, G	12.1 - 11.3	15	2.5 - 2.7
☞☞☞▲▲▲	208 - 240	3	50/60	14 (2.08)	L1, L2, L3, G	9.6 - 8.4	15	2.0	L1, L2, L3, G	12.1 - 11.3	15	2.5 - 2.7
☞☞☞●	380 - 415	3	50/60	14 (2.08)	L1, L2, L3, N, G	9.2 - 8.4	15	2.0	L1, L2, L3, N, G	11.8 - 11.3	15	2.6 - 2.7

☞☞ NORTH AMERICA VOLTAGE CHOICE ☞☞ GROUND FAULT OR RESIDUAL CURRENT PROTECTION DEVICE MUST ACCOMMODATE A LEAKAGE CURRENT OF 20mA ☞☞ INTERNATIONAL VOLTAGE CHOICE
▲ PER UL REQUIREMENTS, MUST BE PERMANENTLY CONNECTED TO ELECTRICAL SUPPLY SOURCE

WEIGHT	SHIP DIMENSIONS	PAN CAPACITY
NET: 1100 lbs (499 kg) est Recessed Door: 1217 lbs (552 kg) est	(L x W x H) 53" x 53" x 87** (1346 x 1346 x 2210mm)*	FULL-SIZE: 20" x 12" x 2-1/2" Forty (40) GN 1/1: 530 x 325 x 65mm Forty (40) GN 2/1: 650 x 530 x 65mm Twenty (20) 20" x 12" x 2-1/2" Twenty (20)
SHIP: 1250 lbs* (567 kg*) Recessed Door: 1350 lbs* (612 kg*)		PRODUCT MAXIMUM: 480 lb (218 kg) VOLUME MAXIMUM: 300 quarts (380 liters) **ON WIRE SHELVES ONLY. ADDITIONAL WIRE SHELVES REQUIRED FOR MAXIMUM CAPACITY.

*DOMESTIC GROUND SHIPPING INFORMATION. CONTACT FACTORY FOR EXPORT WEIGHT AND DIMENSIONS.

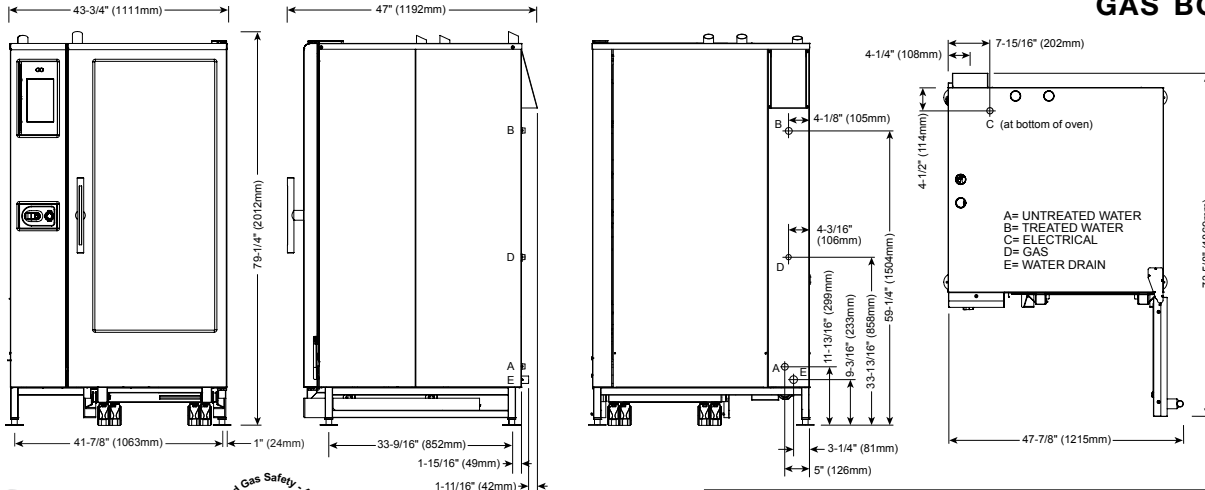

DIMENSIONS: H x W x D
EXTERIOR: 79-1/4" x 43-3/4" x 47" (2012mm x 1111mm x 1192mm)
EXTERIOR WITH RECESSED DOOR: 79-1/4" x 48-3/4" x 47" (2012mm x 1238mm x 1192mm)
INTERIOR: 60-7/16" x 24-1/4" x 32-3/4" (1535mm x 616mm x 832mm)

WATER REQUIREMENTS	
TWO (2) COLD WATER INLETS - DRINKING QUALITY	
ONE (1) TREATED WATER INLET: 3/4" NPT*	* Both inlets can be from same 3/4" source. Divide using a manifold. Run one side through treatment device before running to oven.
ONE (1) UNTREATED WATER INLET: 3/4" NPT*	
LINE PRESSURE: 30 psi minimum dynamic and 90 psi maximum static (200 to 600 kPa)	
WATER DRAIN: 1-1/2" (40mm) CONNECTION WITH A VERTICAL VENT TO EXTEND ABOVE THE EXHAUST VENT. MATERIALS MUST WITHSTAND TEMPERATURES UP TO 200°F (93°C).	
CLEARANCE REQUIREMENTS	
LEFT: 0" (0mm)	18" (457mm) RECOMMENDED SERVICE ACCESS
RIGHT: 0" (0mm) NON-COMBUSTIBLE SURFACES	2" (51mm) DOOR SWING OR COMBUSTIBLE SURFACES
TOP: 20" (508mm) FOR AIR MOVEMENT	
BACK: 4" (102mm)	BOTTOM: 5-1/8" (130mm) FOR LEGS, AIR INTAKE
4-5/16" (109mm) OPTIONAL PLUMBING KIT	
INSTALLATION REQUIREMENTS	
• Oven must be installed level. • Hood installation is required.	
• Water supply shut-off valve and back-flow preventer when required by local code.	

WATER QUALITY STANDARDS	
It is the sole responsibility of the owner/operator/purchaser of this equipment to verify that the incoming water supply is comprehensively tested and if required, a means of "water treatment" provided that would meet compliance requirements with the published water quality standards shown below. Non-compliance with these minimum standards will potentially damage this equipment and/or components and void the original equipment manufacturer's warranty. Alto-Shaam recommends using OptiPure® [www.optipurewater.com] products to properly treat your water.	
Contaminant	Inlet Water Requirements
Free Chlorine	Less than 0.1 ppm (mg/L)
Hardness	30-70 ppm
Chloride	Less than 30 ppm (mg/L)
pH	7.0 to 8.5
Silica	Less than 12 ppm (mg/L)
Total Dissolved Solids (tds)	50-125 ppm

GAS REQUIREMENTS (GAS TYPE MUST BE SPECIFIED ON ORDER) HOOK-UP: 3/4" NPT

UL Marked Appliances	Maximum Input BTU/h	Minimum Input BTU/h	Maximum Inlet Pressure Inches WC	Minimum Inlet Pressure Inches WC	Maximum Fuel Consumption*		AGA Marked Appliances	Maximum Input MJ/h	Minimum Input MJ/h	Maximum Inlet Pressure kPa	Minimum Inlet Pressure kPa	Maximum Fuel Consumption	
					CFH	GPH						m³/h	L/h
Natural Gas	242,000	177,000	14.0	5.5	230.5	N/A	Natural Gas	255.3	186.7	3.48	1.13	6.8	N/A
Propane				9.0	96.8	2.7	Propane				2.75	2.7	10.1

*Assumes an average heating value for natural gas to be 1050 BTU/SCF and a specific gravity of 0.60. The assumed value for propane gas is 2,500 BTU/SCF, and a specific gravity of 1.53

CE Marked Appliances	Maximum Input		Minimum Input		Nominal Gas Pressure mbar	Maximum Gas Pressure mbar	Maximum Fuel Consumption m³
	kWh (Hs)	kWh (Hi)	kWh (Hs)	kWh (Hi)			
2E (G20)					20	50	6.8
2LL (G25)	71.6	64.5	56.0	50.4	20		7.9
3P (G31)					37		2.6
3B/P (G30)	70.1	64.5	54.8	50.4	29		2.6

ELECTRICAL - CTC20-20G (DEDICATED CIRCUIT REQUIRED)

	VOLTAGE	PH	HZ	AWG (mm²)	CONNECTION no cord, no plug	AMPS	BREAKER	KW
☞ ⚡	120	1	60	12 (3.31)	L1, L2/N, G	13.0	20	1.7
☞ ⚡	208 - 240	3	50/60	14 (2.08)	L1, L2, L3, G	9.6 - 8.4	15	2.0
☞ ⚡	380 - 415	3	50/60	14 (2.08)	L1, L2, L3, N, G	9.2 - 8.4	15	2.0

☞ NORTH AMERICA VOLTAGE CHOICE ☞ GROUND FAULT OR RESIDUAL CURRENT PROTECTION DEVICE MUST ACCOMMODATE A LEAKAGE CURRENT OF 20mA ☞ INTERNATIONAL VOLTAGE CHOICE
▲ PER UL REQUIREMENTS, MUST BE PERMANENTLY CONNECTED TO ELECTRICAL SUPPLY SOURCE

WEIGHT	SHIP DIMENSIONS	PAN CAPACITY
NET 1100 lbs (499 kg) est Recessed Door: 1217 lbs (552 kg) est	(L x W x H) 53" x 53" x 87** (1346 x 1346 x 2210mm)*	FULL-SIZE: 20" x 12" x 2-1/2" Forty (40)
SHIP 1250 lbs* (567 kg*) Recessed Door: 1350 lbs* (612 kg)*		GN 1/1: 530 x 325 x 65mm Forty (40) GN 2/1: 650 x 530 x 65mm Twenty (20) **FULL-SIZE SHEET: 18" x 26" x 1" Twenty (20)
*DOMESTIC GROUND SHIPPING INFORMATION. CONTACT FACTORY FOR EXPORT WEIGHT AND DIMENSIONS.		PRODUCT MAXIMUM: 480 lb (218 kg) VOLUME MAXIMUM: 300 quarts (380 liters) **ON WIRE SHELVES ONLY. ADDITIONAL WIRE SHELVES REQUIRED FOR MAXIMUM CAPACITY.

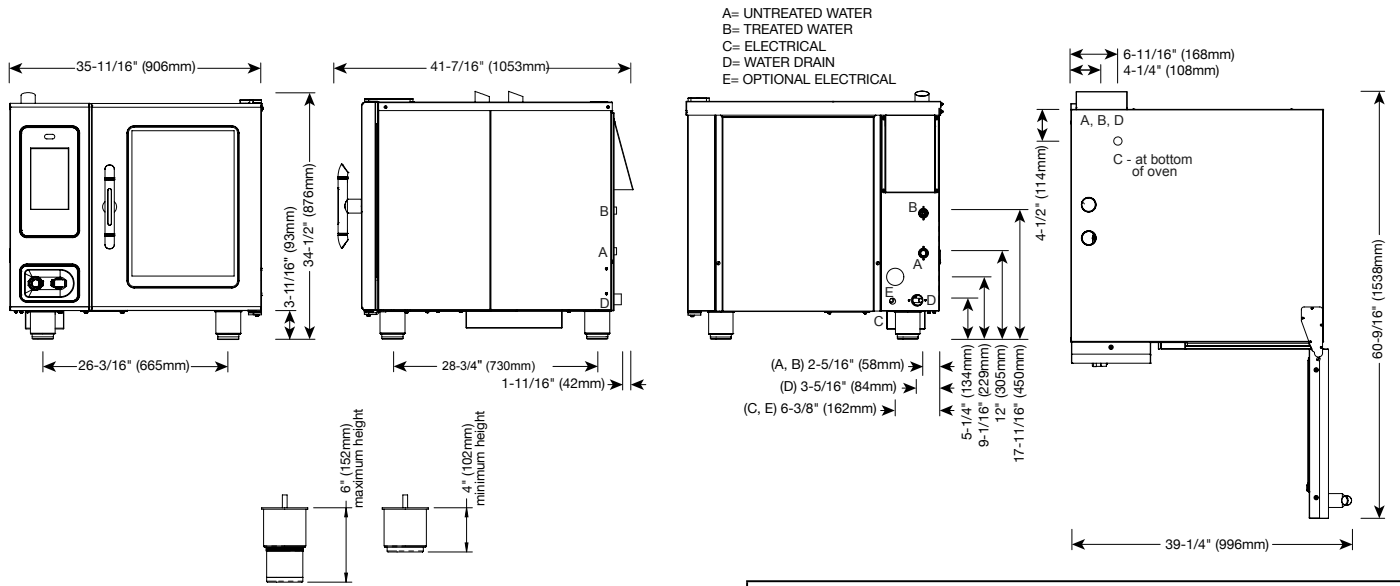

IP X5



DIMENSIONS: H x W x D															
EXTERIOR: 34-1/2" x 35-11/16" x 41-7/16" (876mm x 906mm x 1053mm)															
EXTERIOR WITH RECESSED DOOR: 34-1/2" x 40-11/16" x 41-7/16" (876mm x 1033mm x 1053mm)															
INTERIOR: 20-1/2" x 16-1/4" x 28-1/16" (520mm x 411mm x 712mm)															
WATER REQUIREMENTS	WATER QUALITY STANDARDS														
<p>TWO (2) COLD WATER INLETS - DRINKING QUALITY</p> <p>ONE (1) TREATED WATER INLET: 3/4" NPT* * Both inlets can be from same 3/4" source. Divide using a manifold. Run one side through treatment device before running to oven.</p> <p>ONE (1) UNTREATED WATER INLET: 3/4" NPT*</p> <p>LINE PRESSURE: 30 psi minimum dynamic and 90 psi maximum static (200 to 600 kPa)</p> <p>WATER DRAIN: 1-1/2" (40mm) CONNECTION WITH A VERTICAL VENT TO EXTEND ABOVE THE EXHAUST VENT. MATERIALS MUST WITHSTAND TEMPERATURES UP TO 200°F (93°C).</p>	<p>It is the sole responsibility of the owner/operator/purchaser of this equipment to verify that the incoming water supply is comprehensively tested and if required, a means of "water treatment" provided that would meet compliance requirements with the published water quality standards shown below. Non-compliance with these minimum standards will potentially damage this equipment and/or components and void the original equipment manufacturer's warranty. Alto-Shaam recommends using OptiPure® [www.optipurewater.com] products to properly treat your water.</p> <table border="1"> <thead> <tr> <th>Contaminant</th> <th>Inlet Water Requirements</th> </tr> </thead> <tbody> <tr> <td>Free Chlorine</td> <td>Less than 0.1 ppm (mg/L)</td> </tr> <tr> <td>Hardness</td> <td>30-70 ppm</td> </tr> <tr> <td>Chloride</td> <td>Less than 30 ppm (mg/L)</td> </tr> <tr> <td>pH</td> <td>7.0 to 8.5</td> </tr> <tr> <td>Silica</td> <td>Less than 12 ppm (mg/L)</td> </tr> <tr> <td>Total Dissolved Solids (tds)</td> <td>50-125 ppm</td> </tr> </tbody> </table>	Contaminant	Inlet Water Requirements	Free Chlorine	Less than 0.1 ppm (mg/L)	Hardness	30-70 ppm	Chloride	Less than 30 ppm (mg/L)	pH	7.0 to 8.5	Silica	Less than 12 ppm (mg/L)	Total Dissolved Solids (tds)	50-125 ppm
Contaminant	Inlet Water Requirements														
Free Chlorine	Less than 0.1 ppm (mg/L)														
Hardness	30-70 ppm														
Chloride	Less than 30 ppm (mg/L)														
pH	7.0 to 8.5														
Silica	Less than 12 ppm (mg/L)														
Total Dissolved Solids (tds)	50-125 ppm														
<p>CLEARANCE REQUIREMENTS</p> <table border="1"> <tr> <td>LEFT: 0" (0mm)</td> <td>18" (457mm) RECOMMENDED SERVICE ACCESS</td> </tr> <tr> <td>RIGHT: 0" (0mm) NON-COMBUSTIBLE SURFACES</td> <td>2" (51mm) DOOR SWING OR COMBUSTIBLE SURFACES</td> </tr> <tr> <td>TOP: 20" (508mm) FOR AIR MOVEMENT</td> <td></td> </tr> <tr> <td>BACK: 4" (102mm)</td> <td>BOTTOM: 5-1/8" (130mm) FOR LEGS, AIR INTAKE</td> </tr> <tr> <td>4-5/16" (109mm) OPTIONAL PLUMBING KIT</td> <td></td> </tr> </table>	LEFT: 0" (0mm)	18" (457mm) RECOMMENDED SERVICE ACCESS	RIGHT: 0" (0mm) NON-COMBUSTIBLE SURFACES	2" (51mm) DOOR SWING OR COMBUSTIBLE SURFACES	TOP: 20" (508mm) FOR AIR MOVEMENT		BACK: 4" (102mm)	BOTTOM: 5-1/8" (130mm) FOR LEGS, AIR INTAKE	4-5/16" (109mm) OPTIONAL PLUMBING KIT						
LEFT: 0" (0mm)	18" (457mm) RECOMMENDED SERVICE ACCESS														
RIGHT: 0" (0mm) NON-COMBUSTIBLE SURFACES	2" (51mm) DOOR SWING OR COMBUSTIBLE SURFACES														
TOP: 20" (508mm) FOR AIR MOVEMENT															
BACK: 4" (102mm)	BOTTOM: 5-1/8" (130mm) FOR LEGS, AIR INTAKE														
4-5/16" (109mm) OPTIONAL PLUMBING KIT															
<p>INSTALLATION REQUIREMENTS</p> <ul style="list-style-type: none"> Oven must be installed level. Hood installation is required. Water supply shut-off valve and back-flow preventer when required by local code. 															

ELECTRICAL (NO CORD, NO PLUG - DEDICATED CIRCUIT REQUIRED)									
MODEL	VOLTAGE	PH	HZ	AMPS	kW	BREAKER	AWG	CONNECTION	
CTC6-10E	208 – 240	3	50/60	21.9 – 25.3	7.9 – 10.5	25 - 30	8	L1, L2, L3, G	
	380 – 415	3	50/60	13.4 – 14.6	9.0 – 10.5	16	8	L1, L2, L3, N, G	
	440 – 480	3*	50/60	11.6 – 12.6	9.1 – 10.5	15	10 – 8	L1, L2, L3, G	

*ELECTRICAL SERVICE CHARGE APPLIES

WEIGHT		SHIP DIMENSIONS		PAN CAPACITY		
NET	524 lbs est 238 kg	(L x W x H) 58" x 45" x 51"	(1473 x 1143 x 1295mm)*	FULL-SIZE:	20" x 12" x 2-1/2"	Seven (7)
SHIP	608 lbs* 276 kg*			GN 1/1:	530 x 325 x 65mm	Seven (7)
*DOMESTIC GROUND SHIPPING INFORMATION. CONTACT FACTORY FOR EXPORT WEIGHT AND DIMENSIONS.				*HALF-SIZE SHEET:	18" x 13" x 1"	Seven (7)
				PRODUCT MAXIMUM: 72 lb (33 kg)		
				VOLUME MAXIMUM: 45 quarts (57 liters)		
				**ON WIRE SHELVES ONLY. ADDITIONAL WIRE SHELVES REQUIRED FOR MAXIMUM CAPACITY		

COMBITHERM® CTP6-10E ELECTRIC BOILER-FREE

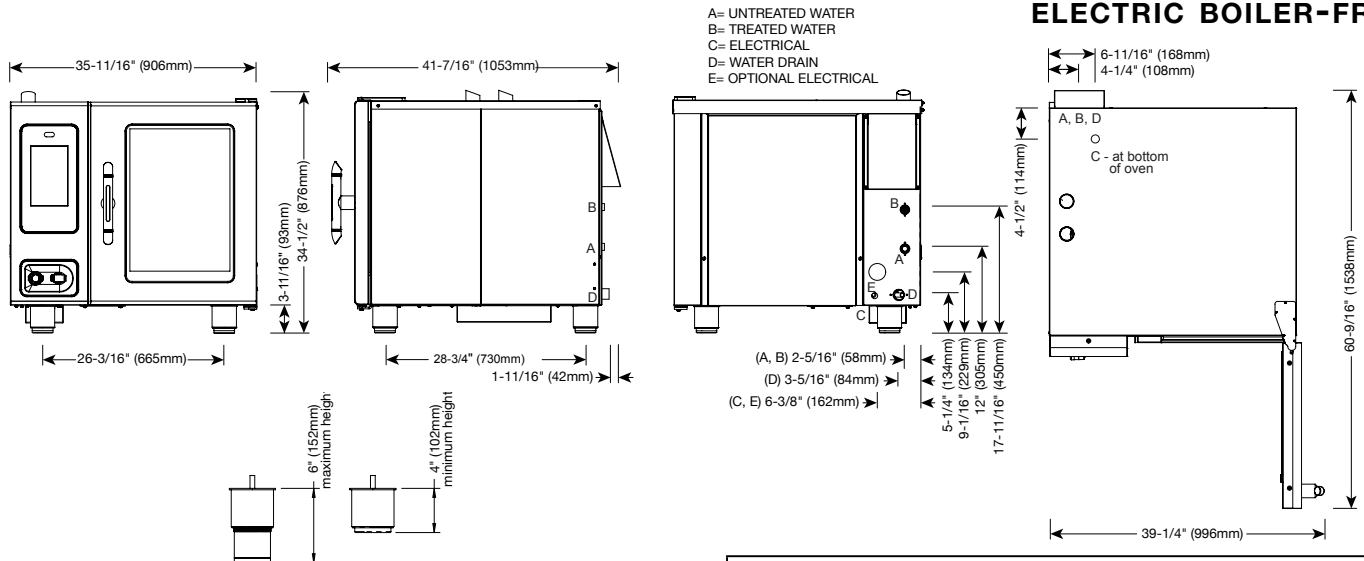

DIMENSIONS: H x W x D
EXTERIOR: 34-1/2" x 35-11/16" x 41-7/16" (876mm x 906mm x 1053mm)
EXTERIOR WITH RECESSED DOOR: 34-1/2" x 40-11/16" x 41-7/16" (876mm x 1033mm x 1053mm)
INTERIOR: 20-1/2" x 16-1/4" x 28-1/16" (520mm x 411mm x 712mm)

WATER REQUIREMENTS	
TWO (2) COLD WATER INLETS - DRINKING QUALITY	
ONE (1) TREATED WATER INLET: 3/4" NPT*	* Both inlets can be from same 3/4" source. Divide using a manifold. Run one side through treatment device before running to oven.
ONE (1) UNTREATED WATER INLET: 3/4" NPT*	
LINE PRESSURE: 30 psi minimum dynamic and 90 psi maximum static (200 to 600 kPa)	
WATER DRAIN: 1-1/2" (40mm) CONNECTION WITH A VERTICAL VENT TO EXTEND ABOVE THE EXHAUST VENT. MATERIALS MUST WITHSTAND TEMPERATURES UP TO 200°F (93°C).	
CLEARANCE REQUIREMENTS	
LEFT: 0" (0mm)	18" (457mm) RECOMMENDED SERVICE ACCESS
RIGHT: 0" (0mm) NON-COMBUSTIBLE SURFACES	2" (51mm) DOOR SWING OR COMBUSTIBLE SURFACES
TOP: 20" (508mm) FOR AIR MOVEMENT	
BACK: 4" (102mm)	BOTTOM: 5-1/8" (130mm) FOR LEGS, AIR INTAKE
INSTALLATION REQUIREMENTS	
• Oven must be installed level. • Hood installation is required.	
• Water supply shut-off valve and back-flow preventer when required by local code.	

WATER QUALITY STANDARDS	
It is the sole responsibility of the owner/operator/purchaser of this equipment to verify that the incoming water supply is comprehensively tested and if required, a means of "water treatment" provided that would meet compliance requirements with the published water quality standards shown below. Non-compliance with these minimum standards will potentially damage this equipment and/or components and void the original equipment manufacturer's warranty. Alto-Shaam recommends using OptiPure® [www.optipurewater.com] products to properly treat your water.	
Contaminant	Inlet Water Requirements
Free Chlorine	Less than 0.1 ppm (mg/L)
Hardness	30-70 ppm
Chloride	Less than 30 ppm (mg/L)
pH	7.0 to 8.5
Silica	Less than 12 ppm (mg/L)
Total Dissolved Solids (tds)	50-125 ppm

ELECTRICAL - CTP6-10E (NO CORD, NO PLUG, DEDICATED CIRCUIT REQUIRED)											WITH COMBISMOKER® OPTION					
					ECO STANDARD			**PROpower™ OPTION			ECO STANDARD			**PROpower™ OPTION		
VOLTAGE	PH	HZ	AWG	CONNECTION	AMPS	kW	BREAKER	AMPS	kW	BREAKER	AMPS	kW	BREAKER	AMPS	kW	BREAKER
208-240	1*	50/60	6	L1, L2/N, G	37.9-43.8	7.9-10.5	40-50	44.2-51.3	9.2-12.3	45-60	40.4-46.6	8.4-11.2	40-50	46.7-54.1	9.7-13	50-60
208-240	3	50/60	8	L1, L2, L3, G	21.9-25.3	7.9-10.5	25-30	28.4-32.6	9.2-12.3	30-35	24.4-28.1	8.4-11.2	25-30	30.9-35.5	9.8-13	35-40
380-415	3	50/60	8	L1, L2, L3, N, G	13.4-14.6	9-10.5	16	20.3-22.1	10.3-12.3	32	16.1-17.5	9.6-11.2	16-32	22.9-25	10.9-13	32
440-480	3*	50/60	10-8	L1, L2, L3, G	11.6-12.6	9.1-10.5	15	15-16.7	10.4-12.3	15-20	12.9-14.1	9.6-11.2	15	16.3-18.2	11-13	20

*ELECTRICAL SERVICE CHARGE APPLIES **NO-COST OPTION ON ELECTRIC MODELS

WEIGHT			PAN CAPACITY			STANDARD MODEL			WITH COMBISMOKER® OPTION		
NET	524 lbs EST	238 kg	FULL-SIZE:	20" x 12" x 2-1/2"		Seven (7)			Six (6)		
SHIP	608 lbs*	276 kg*	GN 1/1:	530 x 325 x 65mm		Seven (7)			Six (6)		
			**HALF-SIZE SHEET:	18" x 13" x 1"		Seven (7)			Seven (7)		
SHIP DIMENSIONS			PRODUCT CAPACITY								
(L x W x H) 58" x 45" x 51"			PRODUCT MAXIMUM						72 lb (33 kg)		
(1473mm x 1143mm x 1295mm)*			VOLUME MAXIMUM						45 quarts (57 liters)		
*DOMESTIC GROUND SHIPPING INFORMATION. CONTACT FACTORY FOR EXPORT WEIGHT AND DIMENSIONS.			**ON WIRE SHELVES ONLY. ADDITIONAL WIRE SHELVES REQUIRED FOR MAXIMUM CAPACITY								

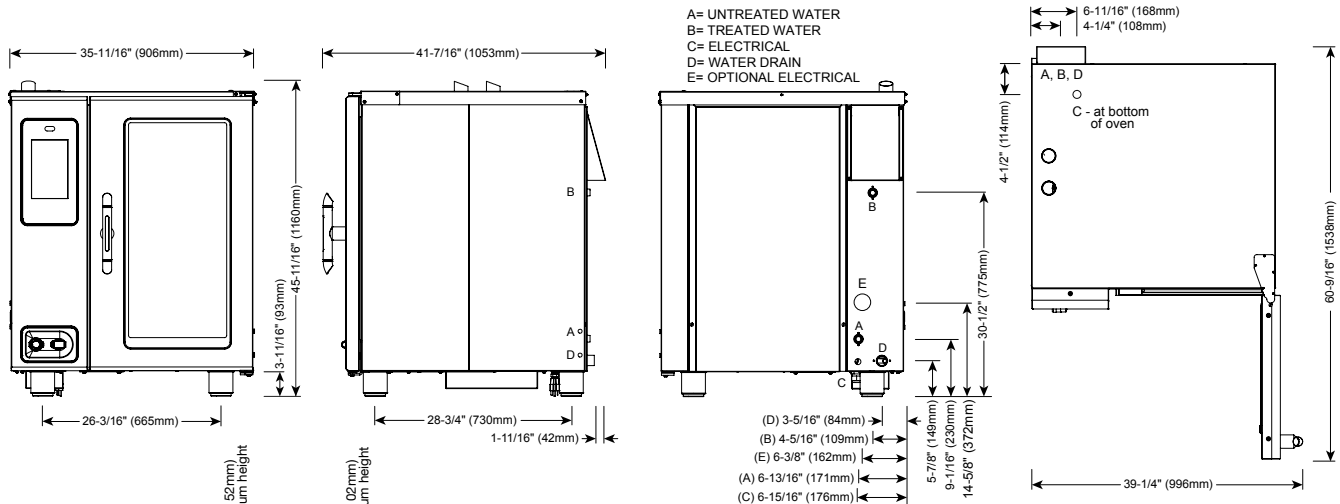

DIMENSIONS: H x W x D
EXTERIOR: 45-11/16" x 35-11/16" x 41-7/16" (1160mm x 906mm x 1053mm)
EXTERIOR WITH RECESSED DOOR: 45-11/16" x 40-11/16" x 41-7/16" (1160mm x 1033mm x 1053mm)
INTERIOR: 31-1/2" x 16-1/4" x 28-1/16" (800mm x 411mm x 712mm)

WATER REQUIREMENTS

TWO (2) COLD WATER INLETS - DRINKING QUALITY

ONE (1) TREATED WATER INLET: 3/4" NPT* *Both inlets can be from same 3/4" source. Divide using a manifold. Run one side through treatment device before running to oven.

ONE (1) UNTREATED WATER INLET: 3/4" NPT*

LINE PRESSURE: 30 psi minimum dynamic and 90 psi maximum static (200 to 600 kPa)

WATER DRAIN: 1-1/2" (40mm) CONNECTION WITH A VERTICAL VENT TO EXTEND ABOVE THE EXHAUST VENT. MATERIALS MUST WITHSTAND TEMPERATURES UP TO 200°F (93°C).

WATER QUALITY STANDARDS

It is the sole responsibility of the owner/operator/purchaser of this equipment to verify that the incoming water supply is comprehensively tested and if required, a means of "water treatment" provided that would meet compliance requirements with the published water quality standards shown below. Non-compliance with these minimum standards will potentially damage this equipment and/or components and void the original equipment manufacturer's warranty. Alto-Shaam recommends using OptiPure® [www.optipurewater.com] products to properly treat your water.

CLEARANCE REQUIREMENTS

LEFT: 0" (0mm)	18" (457mm) RECOMMENDED SERVICE ACCESS
RIGHT: 0" (0mm) NON-COMBUSTIBLE SURFACES	2" (51mm) DOOR SWING OR COMBUSTIBLE SURFACES
TOP: 20" (508mm) FOR AIR MOVEMENT	
BACK: 4" (102mm) 4-5/16" (109mm) OPTIONAL PLUMBING KIT	BOTTOM: 5-1/8" (130mm) FOR LEGS, AIR INTAKE

Contaminant	Inlet Water Requirements
Free Chlorine	Less than 0.1 ppm (mg/L)
Hardness	30-70 ppm
Chloride	Less than 30 ppm (mg/L)
pH	7.0 to 8.5
Silica	Less than 12 ppm (mg/L)
Total Dissolved Solids (tds)	50-125 ppm

INSTALLATION REQUIREMENTS

- Oven must be installed level.
- Hood installation is required.
- Water supply shut-off valve and back-flow preventer when required by local code.

ELECTRICAL - CTP10-10E (NO CORD, NO PLUG, DEDICATED CIRCUIT REQUIRED)										WITH COMBISMOKER® OPTION						
					ECO STANDARD			**PROpower™ OPTION			ECO STANDARD			**PROpower™ OPTION		
VOLTAGE	PH	HZ	AWG	CONNECTION	AMPS	KW	BREAKER	AMPS	KW	BREAKER	AMPS	KW	BREAKER	AMPS	KW	BREAKER
208-240	1*	50/60	2	L1, L2/N, G	68.3-78.8	14.2-18.9	70-80	79.8-92.1	16.6-22.1	80-100	70.8-81.6	14.7-19.6	70-90	82.3-95	17.1-22.8	90-100
208-240	3	50/60	4	L1, L2, L3, G	39.4-45.5	14.2-18.9	40-50	51-58.8	16.6-22.1	60	41.9-48.3	14.7-19.6	50	53.5-61.7	17.1-22.8	60-70
380-415	3	50/60	6	L1, L2, L3, N, G	24.1-26.3	16.2-18.9	32	36.4-39.6	18.6-22.1	63	26.8-29.1	16.7-19.6	32-63	39-42.5	19.2-22.8	63
440-480	3*	50/60	8	L1, L2, L3, G	20.8-22.7	16.2-18.9	25	26.9-29.4	18.6-22.1	30	22.2-24.2	16.7-19.6	25	28.3-30.8	19.2-22.8	30

*ELECTRICAL SERVICE CHARGE APPLIES **NO-COST OPTION ON ELECTRIC MODELS

WEIGHT			PAN CAPACITY		STANDARD MODEL		WITH COMBISMOKER® OPTION	
NET	625 lbs EST	283 kg	FULL-SIZE:	20" x 12" x 2-1/2"	Eleven (11)		Ten (10)	
			GN 1/1:	530 x 325 x 65mm	Eleven (11)		Ten (10)	
SHIP	650 lbs*	295 kg*	**HALF-SIZE SHEET:	18" x 13" x 1"	Eleven (11)		Eleven (11)	
SHIP DIMENSIONS			PRODUCT CAPACITY					
(L x W x H) 45" x 45" x 65"			PRODUCT MAXIMUM			120 lb (54 kg)		
(1143mm x 1143mm x 1651mm)*			VOLUME MAXIMUM			75 quarts (95 liters)		
*DOMESTIC GROUND SHIPPING INFORMATION. CONTACT FACTORY FOR EXPORT WEIGHT AND DIMENSIONS.			**ON WIRE SHELVES ONLY. ADDITIONAL WIRE SHELVES REQUIRED FOR MAXIMUM CAPACITY					

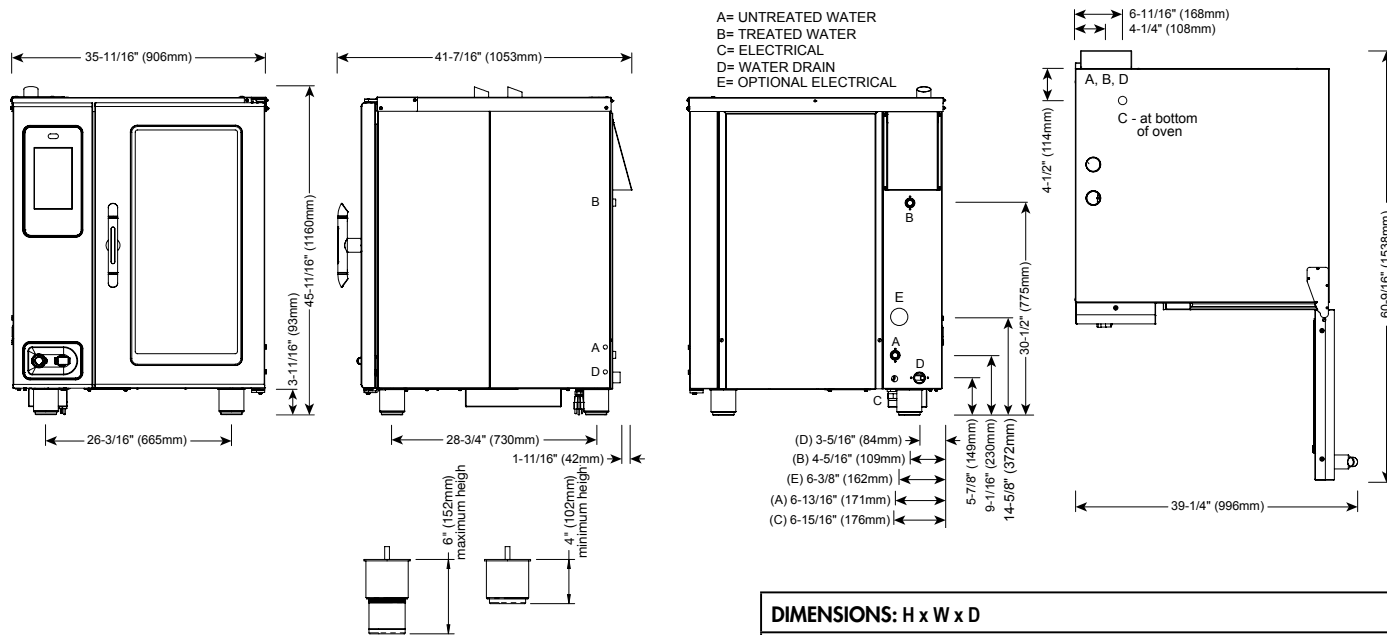

DIMENSIONS: H x W x D
EXTERIOR: 45-11/16" x 35-11/16" x 41-7/16" (1160mm x 906mm x 1053mm)
EXTERIOR WITH RECESSED DOOR: 45-11/16" x 40-11/16" x 41-7/16" (1160mm x 1033mm x 1053mm)
INTERIOR: 31-1/2" x 16-1/4" x 28-1/16" (800mm x 411mm x 712mm)

WATER REQUIREMENTS	
TWO (2) COLD WATER INLETS - DRINKING QUALITY	
ONE (1) TREATED WATER INLET: 3/4" NPT*	* Both inlets can be from same 3/4" source. Divide using a manifold. Run one side through treatment device before running to oven.
ONE (1) UNTREATED WATER INLET: 3/4" NPT*	
LINE PRESSURE: 30 psi minimum dynamic and 90 psi maximum static (200 to 600 kPa)	
WATER DRAIN: 1-1/2" (40mm) CONNECTION WITH A VERTICAL VENT TO EXTEND ABOVE THE EXHAUST VENT. MATERIALS MUST WITHSTAND TEMPERATURES UP TO 200°F (93°C).	
CLEARANCE REQUIREMENTS	
LEFT: 0" (0mm)	18" (457mm) RECOMMENDED SERVICE ACCESS
RIGHT: 0" (0mm) NON-COMBUSTIBLE SURFACES	2" (51mm) DOOR SWING OR COMBUSTIBLE SURFACES
TOP: 20" (508mm) FOR AIR MOVEMENT	
BACK: 4" (102mm)	BOTTOM: 5-1/8" (130mm) FOR LEGS, AIR INTAKE
4-5/16" (109mm) OPTIONAL PLUMBING KIT	
INSTALLATION REQUIREMENTS	
<ul style="list-style-type: none"> Oven must be installed level. Hood installation is required. Water supply shut-off valve and back-flow preventer when required by local code. 	

WATER QUALITY STANDARDS	
It is the sole responsibility of the owner/operator/purchaser of this equipment to verify that the incoming water supply is comprehensively tested and if required, a means of "water treatment" provided that would meet compliance requirements with the published water quality standards shown below. Non-compliance with these minimum standards will potentially damage this equipment and/or components and void the original equipment manufacturer's warranty. Alto-Shaam recommends using OptiPure® [www.optipurewater.com] products to properly treat your water.	
Contaminant	Inlet Water Requirements
Free Chlorine	Less than 0.1 ppm (mg/L)
Hardness	30-70 ppm
Chloride	Less than 30 ppm (mg/L)
pH	7.0 to 8.5
Silica	Less than 12 ppm (mg/L)
Total Dissolved Solids (tds)	50-125 ppm

ELECTRICAL (NO CORD, NO PLUG, DEDICATED CIRCUIT REQUIRED)								
MODEL	VOLTAGE	PH	HZ	AMPS	kW	BREAKER	AWG	CONNECTION
CTC10-10E	208 – 240	3	50/60	39.4 – 45.5	14.2 – 18.9	40-50	4	L1, L2, L3, G
	380 – 415	3	50/60	24.1 – 26.2	16.2 – 18.9	32	6	L1, L2, L3, N, G
	440 – 480	3*	50/60	20.8 – 22.7	16.2 – 18.9	25	8	L1, L2, L3, G

*ELECTRICAL SERVICE CHARGE APPLIES

WEIGHT	SHIP DIMENSIONS	PAN CAPACITY	
NET 625 lbs est 283 kg	(L x W x H) 45" x 45" x 65"	FULL-SIZE: 20" x 12" x 2-1/2"	Eleven (11)
SHIP 650 lbs* 295 kg*	(1143 x 1143 x 1651mm)*	GN 1/1: 530 x 325 x 65mm	Eleven (11)
*DOMESTIC GROUND SHIPPING INFORMATION. CONTACT FACTORY FOR EXPORT WEIGHT AND DIMENSIONS.		**HALF-SIZE SHEET: 18" x 13" x 1"	Eleven (11)
		PRODUCT MAXIMUM: 120 lb (54 kg)	
		VOLUME MAXIMUM: 75 quarts (95 liters)	
		**ON WIRE SHELVES ONLY. ADDITIONAL WIRE SHELVES REQUIRED FOR MAXIMUM CAPACITY	



COMBITHERM® CTP7-20E

ELECTRIC BOILER-FREE

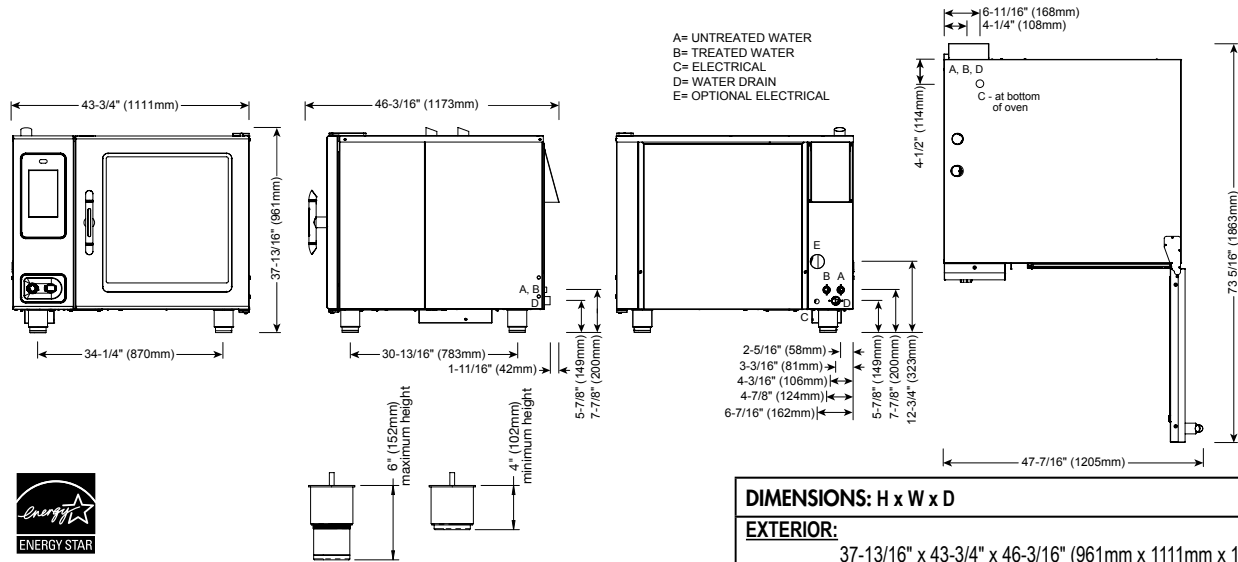

IP X5



DIMENSIONS: H x W x D
EXTERIOR: 37-13/16" x 43-3/4" x 46-3/16" (961mm x 1111mm x 1173mm)
EXTERIOR WITH RECESSED DOOR: 37-13/16" x 48-3/4" x 46-3/16" (961mm x 1238mm x 1173mm)
INTERIOR: 23-1/4" x 24-1/4" x 32-3/4" (590mm x 616mm x 832mm)

WATER REQUIREMENTS	
TWO (2) COLD WATER INLETS - DRINKING QUALITY	
ONE (1) TREATED WATER INLET: 3/4" NPT*	* Can manifold off of one 3/4" line
ONE (1) UNTREATED WATER INLET: 3/4" NPT*	
LINE PRESSURE: 30 psi minimum dynamic and 90 psi maximum static (200 to 600 kPa)	
WATER DRAIN: 1-1/2" (40mm) CONNECTION WITH A VERTICAL VENT TO EXTEND ABOVE THE EXHAUST VENT.	
MATERIALS MUST WITHSTAND TEMPERATURES UP TO 200°F (93°C).	
CLEARANCE REQUIREMENTS	
LEFT: 0" (0mm)	18" (457mm) RECOMMENDED SERVICE ACCESS
RIGHT: 0" (0mm) NON-COMBUSTIBLE SURFACES	2" (51mm) DOOR SWING OR COMBUSTIBLE SURFACES
TOP: 20" (508mm) FOR AIR MOVEMENT	
BACK: 4" (102mm) 4-5/16" (109mm) OPTIONAL PLUMBING KIT	BOTTOM: 5-1/8" (130mm) FOR LEGS, AIR INTAKE
INSTALLATION REQUIREMENTS	
<ul style="list-style-type: none"> Oven must be installed level. Hood installation is required. Water supply shut-off valve and back-flow preventer when required by local code. 	

WATER QUALITY STANDARDS	
It is the sole responsibility of the owner/operator/purchaser of this equipment to verify that the incoming water supply is comprehensively tested and if required, a means of "water treatment" provided that would meet compliance requirements with the published water quality standards shown below. Non-compliance with these minimum standards will potentially damage this equipment and/or components and void the original equipment manufacturer's warranty. Alto-Shaam recommends using OptiPure® [www.optipurewater.com] products to properly treat your water.	
Contaminant	Inlet Water Requirements
Free Chlorine	Less than 0.1 ppm (mg/L)
Hardness	30-70 ppm
Chloride	Less than 30 ppm (mg/L)
pH	7.0 to 8.5
Silica	Less than 12 ppm (mg/L)
Total Dissolved Solids (tds)	50-125 ppm

ELECTRICAL - CTP7-20E (NO CORD, NO PLUG, DEDICATED CIRCUIT REQUIRED)												WITH COMBISMOKER® OPTION					
ECO STANDARD						**PROpower™ OPTION						ECO STANDARD			**PROpower™ OPTION		
VOLTAGE	PH	HZ	AWG	CONNECTION	AMPS	KW	BREAKER	AMPS	KW	BREAKER	AMPS	KW	BREAKER	AMPS	KW	BREAKER	
208-240	1*	50/60	1-1/0	L1, L2/N, G	79.1-91.3	16.5-21.9	80-100	92.1-106.3	19.2-25.5	100-110	81.6-94.1	17-22.6	90-100	94.6-109.1	19.7-26.2	100-110	
208-240	3	50/60	4-3	L1, L2, L3, G	45.7-52.7	16.5-21.9	50-60	58.7-67.7	19.2-25.5	60-70	48.2-55.6	17-22.6	50-60	61.2-70.6	19.7-26.2	70	
380-415	3	50/60	6-4	L1, L2, L3, N, G	28-30.4	18.7-21.9	32	41.7-45.4	21.4-25.5	63	30.6-33.3	19.3-22.6	32-63	44.4-48.3	22-26.2	63	
440-480	3*	50/60	8	L1, L2, L3, G	20.6-22.4	15.7-18.7	25	26.5-28.8	18.3-21.8	30-35	21.9-23.8	16.2-19.2	30	27.3-30.0	18.8-22.3	30-35	

*ELECTRICAL SERVICE CHARGE APPLIES

**NO-COST OPTION ON ELECTRIC MODELS

WEIGHT			PAN CAPACITY			STANDARD MODEL			WITH COMBISMOKER® OPTION					
NET	680 lbs EST	308 kg	FULL-SIZE:	20" x 12" x 2-1/2"	Sixteen (16)	Fifteen (15)	GN 1/1:	530 x 325 x 65mm	Sixteen (16)	Fifteen (15)	GN 2/1:	650 x 530 x 65mm	Eight (8)	Seven (7)
SHIP	727 lbs*	330 kg*	**FULL-SIZE SHEET:	18" x 26" x 1"	Eight (8)	Eight (8)								
SHIP DIMENSIONS			PRODUCT CAPACITY											
(L x W x H) 56" x 49" x 65"			PRODUCT MAXIMUM			168 lb (76 kg)								
(1422mm x 1245mm x 1651mm)*			VOLUME MAXIMUM			105 quarts (133 liters)								
*DOMESTIC GROUND SHIPPING INFORMATION. CONTACT FACTORY FOR EXPORT WEIGHT AND DIMENSIONS.			**ON WIRE SHELVES ONLY. ADDITIONAL WIRE SHELVES REQUIRED FOR MAXIMUM CAPACITY											

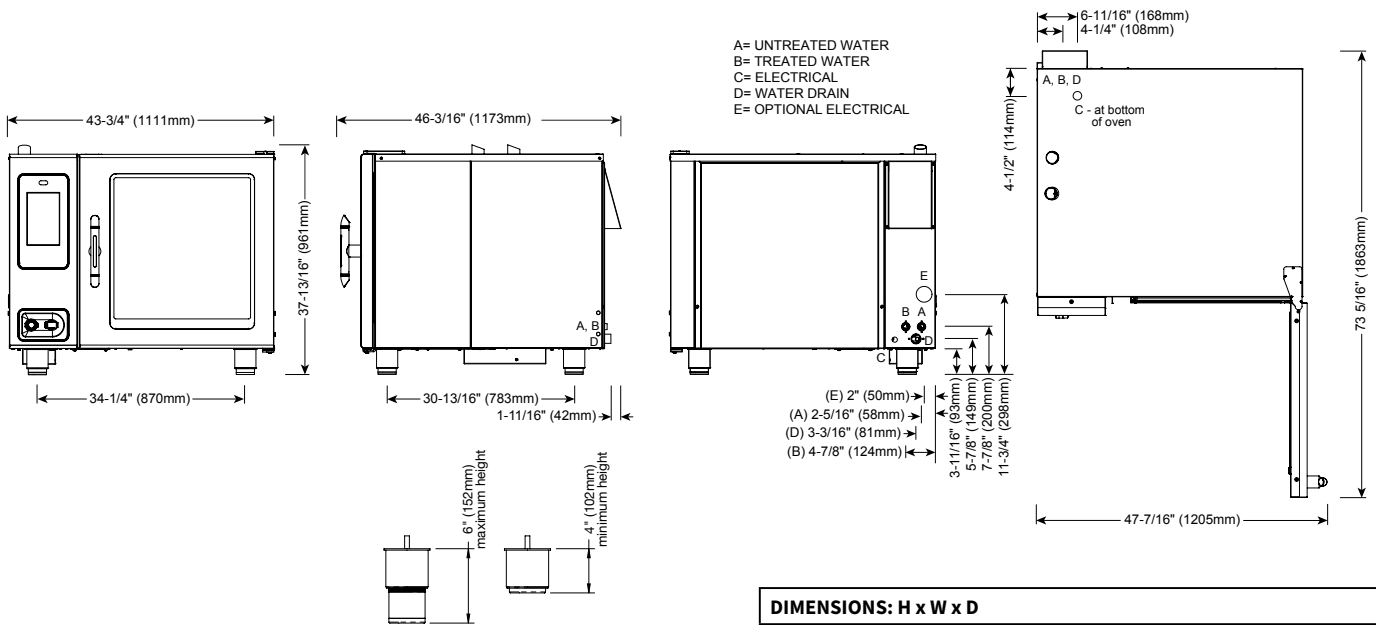

DIMENSIONS: H x W x D
EXTERIOR: 37-13/16" x 43-3/4" x 46-3/16" (961mm x 1111mm x 1173mm)
EXTERIOR WITH RECESSED DOOR: 37-13/16" x 48-3/4" x 46-3/16" (961mm x 1238mm x 1173mm)
INTERIOR: 23-1/4" x 24-1/4" x 32-3/4" (590mm x 616mm x 832mm)

WATER REQUIREMENTS	
TWO (2) COLD WATER INLETS - DRINKING QUALITY	
ONE (1) TREATED WATER INLET: 3/4" NPT*	* Both inlets can be from same 3/4" source. Divide using a manifold. Run one side through treatment device before running to oven.
ONE (1) UNTREATED WATER INLET: 3/4" NPT*	
LINE PRESSURE: 30 psi minimum dynamic and 90 psi maximum static (200 to 600 kPa)	
WATER DRAIN: 1-1/2" (40mm) CONNECTION WITH A VERTICAL VENT TO EXTEND ABOVE THE EXHAUST VENT. MATERIALS MUST WITHSTAND TEMPERATURES UP TO 200°F (93°C).	
CLEARANCE REQUIREMENTS	
LEFT: 0" (0mm)	18" (457mm) RECOMMENDED SERVICE ACCESS
RIGHT: 0" (0mm) NON-COMBUSTIBLE SURFACES	2" (51mm) DOOR SWING OR COMBUSTIBLE SURFACES
TOP: 20" (508mm) FOR AIR MOVEMENT	
4" (102mm)	
BACK: 4-5/16" (109mm) OPTIONAL PLUMBING KIT	BOTTOM: 5-1/8" (130mm) FOR LEGS, AIR INTAKE
INSTALLATION REQUIREMENTS	
<ul style="list-style-type: none"> Oven must be installed level. Hood installation is required. Water supply shut-off valve and back-flow preventer when required by local code. 	

WATER QUALITY STANDARDS	
It is the sole responsibility of the owner/operator/purchaser of this equipment to verify that the incoming water supply is comprehensively tested and if required, a means of "water treatment" provided that would meet compliance requirements with the published water quality standards shown below. Non-compliance with these minimum standards will potentially damage this equipment and/or components and void the original equipment manufacturer's warranty. Alto-Shaam recommends using OptiPure® [www.optipurewater.com] products to properly treat your water.	
Contaminant	Inlet Water Requirements
Free Chlorine	Less than 0.1 ppm (mg/L)
Hardness	30-70 ppm
Chloride	Less than 30 ppm (mg/L)
pH	7.0 to 8.5
Silica	Less than 12 ppm (mg/L)
Total Dissolved Solids (tds)	50-125 ppm

ELECTRICAL (NO CORD, NO PLUG, DEDICATED CIRCUIT REQUIRED)									
MODEL	VOLTAGE	PH	HZ	AMPS	kW	BREAKER	AWG	CONNECTION	
CTC7-20E	208 - 240	3	50/60	45.7 - 52.7	16.5 - 21.9	50-60	4 - 3	L1, L2, L3, G	
	380 - 415	3	50/60	28 - 30.4	18.7 - 21.9	32	6 - 4	L1, L2, L3, N, G	
	440 - 480	3*	50/60	20.6 - 22.4	15.7 - 18.7	25	8	L1, L2, L3, G	

*ELECTRICAL SERVICE CHARGE APPLIES

WEIGHT		SHIP DIMENSIONS		PAN CAPACITY				
NET	680 lbs est 308 kg	(L x W x H) 56" x 49" x 65"*		FULL-SIZE:	20" x 12" x 2-1/2"	Sixteen (16)	PRODUCT MAXIMUM: 168 lb (76 kg)	
SHIP	727 lbs* 330 kg*	(1422 x 1245 x 1651mm)*		GN 1/1:	530 x 325 x 65mm	Sixteen (16)	VOLUME MAXIMUM: 105 quarts (133 liters)	
				GN 2/1:	650 x 530 x 65mm	Eight (8)		
				**FULL-SIZE SHEET:	18" x 26" x 1"	Eight (8)		

*DOMESTIC GROUND SHIPPING INFORMATION. CONTACT FACTORY FOR EXPORT WEIGHT AND DIMENSIONS.

**ON WIRE SHELVES ONLY. ADDITIONAL WIRE SHELVES REQUIRED FOR MAXIMUM CAPACITY

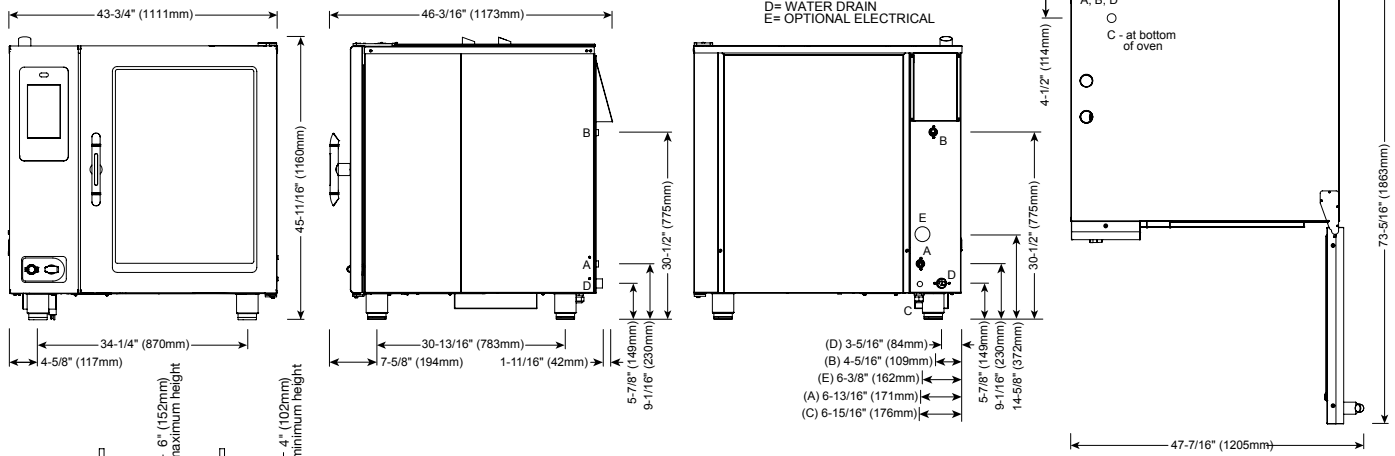

DIMENSIONS: H x W x D
EXTERIOR: 45-11/16" x 43-3/4" x 46-3/16" (1160mm x 1111mm x 1173mm)
EXTERIOR WITH RECESSED DOOR: 45-11/16" x 48-3/4" x 46-3/16" (1160mm x 1238mm x 1173mm)
INTERIOR: 31-1/2" x 24-1/4" x 32-3/4" (800mm x 616mm x 832mm)

WATER REQUIREMENTS	
TWO (2) COLD WATER INLETS - DRINKING QUALITY	
ONE (1) TREATED WATER INLET: 3/4" NPT*	* Can manifold off of one 3/4" line
ONE (1) UNTREATED WATER INLET: 3/4" NPT*	
LINE PRESSURE: 30 psi minimum dynamic and 90 psi maximum static (200 to 600 kPa)	
WATER DRAIN: 1-1/2" (40mm) CONNECTION WITH A VERTICAL VENT TO EXTEND ABOVE THE EXHAUST VENT. MATERIALS MUST WITHSTAND TEMPERATURES UP TO 200°F (93°C).	
CLEARANCE REQUIREMENTS	
LEFT: 0" (0mm)	18" (457mm) RECOMMENDED SERVICE ACCESS
RIGHT: 0" (0mm) NON-COMBUSTIBLE SURFACES	2" (51mm) DOOR SWING OR COMBUSTIBLE SURFACES
TOP: 20" (508mm) FOR AIR MOVEMENT	
BACK: 4" (102mm)	BOTTOM: 5-1/8" (130mm) FOR LEGS, AIR INTAKE
INSTALLATION REQUIREMENTS	
• Oven must be installed level. • Hood installation is required.	
• Water supply shut-off valve and back-flow preventer when required by local code.	

WATER QUALITY STANDARDS	
It is the sole responsibility of the owner/operator/purchaser of this equipment to verify that the incoming water supply is comprehensively tested and if required, a means of "water treatment" provided that would meet compliance requirements with the published water quality standards shown below. Non-compliance with these minimum standards will potentially damage this equipment and/or components and void the original equipment manufacturer's warranty. Alto-Shaam recommends using OptiPure® [www.optipurewater.com] products to properly treat your water.	
Contaminant	Inlet Water Requirements
Free Chlorine	Less than 0.1 ppm (mg/L)
Hardness	30-70 ppm
Chloride	Less than 30 ppm (mg/L)
pH	7.0 to 8.5
Silica	Less than 12 ppm (mg/L)
Total Dissolved Solids (tds)	50-125 ppm

ELECTRICAL - CTP10-20E (NO CORD, NO PLUG, DEDICATED CIRCUIT REQUIRED)										WITH COMBISMOKER® OPTION						
					ECO STANDARD			**PROpower™ OPTION			ECO STANDARD			**PROpower™ OPTION		
VOLTAGE	PH	HZ	AWG	CONNECTION	AMPS	KW	BREAKER	AMPS	KW	BREAKER	AMPS	KW	BREAKER	AMPS	KW	BREAKER
208-240	3	50/60	2-1	L1, L2, L3, G	68.8-79.4	24.8-33	70-80	88.7-102.3	28.9-38.5	90-110	71.3-82.3	25.3-33.7	80-90	91.2-105.2	29.4-39.2	100-110
380-415	3	50/60	4-3	L1, L2, L3, N, G	42.1-45.8	28.2-33	63	63.2-68.8	32.3-38.5	63-80	44.8-48.7	28.8-33.7	63	65.8-71.6	32.9-39.2	100
440-480	3*	50/60	6-4	L1, L2, L3, G	36.4-39.7	28.3-33	40	46.9-51.2	32.4-38.5	50-60	37.7-41.1	28.8-33.7	40-50	48.2-52.6	33-39.2	50-60

*ELECTRICAL SERVICE CHARGE APPLIES

**NO-COST OPTION ON ELECTRIC MODELS

WEIGHT			PAN CAPACITY		STANDARD MODEL		WITH COMBISMOKER® OPTION	
NET	760 lbs EST	345 kg	FULL-SIZE:	20" x 12" x 2-1/2"	Twenty-two (22)		Twenty-one (21)	
SHIP	805 lbs*	365 kg*	GN 1/1:	530 x 325 x 65mm	Twenty-two (22)		Twenty-one (21)	
			GN 2/1:	650 x 530 x 65mm	Eleven (11)		Ten (10)	
			**FULL-SIZE SHEET:	18" x 26" x 1"	Eleven (11)		Eleven (11)	
SHIP DIMENSIONS			PRODUCT CAPACITY					
(L x W x H) 56" x 49" x 65** (1422mm x 1245mm x 1651mm)*			PRODUCT MAXIMUM		240 lb (109 kg)			
			VOLUME MAXIMUM		150 quarts (190 liters)			
*DOMESTIC GROUND SHIPPING INFORMATION. CONTACT FACTORY FOR EXPORT WEIGHT AND DIMENSIONS.			**ON WIRE SHELVES ONLY. ADDITIONAL WIRE SHELVES REQUIRED FOR MAXIMUM CAPACITY					

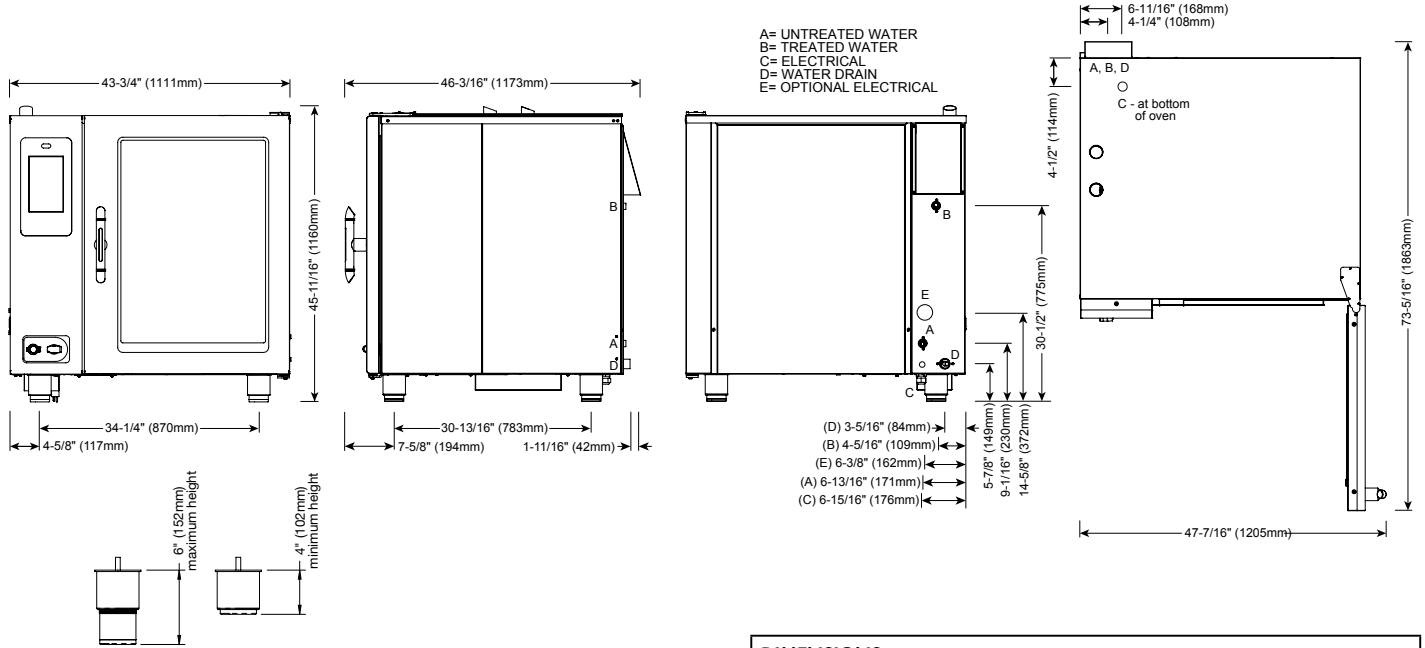

DIMENSIONS: H x W x D
EXTERIOR: 45-11/16" x 43-3/4" x 46-3/16" (1160mm x 1111mm x 1173mm)
EXTERIOR WITH RECESSED DOOR: 45-11/16" x 48-3/4" x 46-3/16" (1160mm x 1238mm x 1173mm)
INTERIOR: 31-1/2" x 24-1/4" x 32-3/4" (800mm x 616mm x 832mm)

WATER REQUIREMENTS	WATER QUALITY STANDARDS														
<p>TWO (2) COLD WATER INLETS - DRINKING QUALITY</p> <p>ONE (1) TREATED WATER INLET: 3/4" NPT* * Both inlets can be from same 3/4" source. Divide using a manifold. Run one side through treatment device before running to oven.</p> <p>ONE (1) UNTREATED WATER INLET: 3/4" NPT*</p> <p>LINE PRESSURE: 30 psi minimum dynamic and 90 psi maximum static (200 to 600 kPa)</p> <p>WATER DRAIN: 1-1/2" (40mm) CONNECTION WITH A VERTICAL VENT TO EXTEND ABOVE THE EXHAUST VENT. MATERIALS MUST WITHSTAND TEMPERATURES UP TO 200°F (93°C).</p>	<p>It is the sole responsibility of the owner/operator/purchaser of this equipment to verify that the incoming water supply is comprehensively tested and if required, a means of "water treatment" provided that would meet compliance requirements with the published water quality standards shown below. Non-compliance with these minimum standards will potentially damage this equipment and/or components and void the original equipment manufacturer's warranty. Alto-Shaam recommends using OptiPure® [www.optipurewater.com] products to properly treat your water.</p> <table border="1"> <thead> <tr> <th>Contaminant</th> <th>Inlet Water Requirements</th> </tr> </thead> <tbody> <tr> <td>Free Chlorine</td> <td>Less than 0.1 ppm (mg/L)</td> </tr> <tr> <td>Hardness</td> <td>30-70 ppm</td> </tr> <tr> <td>Chloride</td> <td>Less than 30 ppm (mg/L)</td> </tr> <tr> <td>pH</td> <td>7.0 to 8.5</td> </tr> <tr> <td>Silica</td> <td>Less than 12 ppm (mg/L)</td> </tr> <tr> <td>Total Dissolved Solids (tds)</td> <td>50-125 ppm</td> </tr> </tbody> </table>	Contaminant	Inlet Water Requirements	Free Chlorine	Less than 0.1 ppm (mg/L)	Hardness	30-70 ppm	Chloride	Less than 30 ppm (mg/L)	pH	7.0 to 8.5	Silica	Less than 12 ppm (mg/L)	Total Dissolved Solids (tds)	50-125 ppm
Contaminant		Inlet Water Requirements													
Free Chlorine	Less than 0.1 ppm (mg/L)														
Hardness	30-70 ppm														
Chloride	Less than 30 ppm (mg/L)														
pH	7.0 to 8.5														
Silica	Less than 12 ppm (mg/L)														
Total Dissolved Solids (tds)	50-125 ppm														
<p>CLEARANCE REQUIREMENTS</p> <table border="1"> <tr> <td>LEFT: 0" (0mm)</td> <td>18" (457mm) RECOMMENDED SERVICE ACCESS</td> </tr> <tr> <td>RIGHT: 0" (0mm) NON-COMBUSTIBLE SURFACES</td> <td>2" (51mm) DOOR SWING OR COMBUSTIBLE SURFACES</td> </tr> <tr> <td>TOP: 20" (508mm) FOR AIR MOVEMENT</td> <td></td> </tr> <tr> <td>BACK: 4" (102mm)</td> <td>BOTTOM: 5-1/8" (130mm) FOR LEGS, AIR INTAKE</td> </tr> <tr> <td></td> <td>4-5/16" (109mm) OPTIONAL PLUMBING KIT</td> </tr> </table> <p>INSTALLATION REQUIREMENTS</p> <ul style="list-style-type: none"> Oven must be installed level. Hood installation is required. Water supply shut-off valve and back-flow preventer when required by local code. 	LEFT: 0" (0mm)	18" (457mm) RECOMMENDED SERVICE ACCESS	RIGHT: 0" (0mm) NON-COMBUSTIBLE SURFACES	2" (51mm) DOOR SWING OR COMBUSTIBLE SURFACES	TOP: 20" (508mm) FOR AIR MOVEMENT		BACK: 4" (102mm)	BOTTOM: 5-1/8" (130mm) FOR LEGS, AIR INTAKE		4-5/16" (109mm) OPTIONAL PLUMBING KIT					
LEFT: 0" (0mm)	18" (457mm) RECOMMENDED SERVICE ACCESS														
RIGHT: 0" (0mm) NON-COMBUSTIBLE SURFACES	2" (51mm) DOOR SWING OR COMBUSTIBLE SURFACES														
TOP: 20" (508mm) FOR AIR MOVEMENT															
BACK: 4" (102mm)	BOTTOM: 5-1/8" (130mm) FOR LEGS, AIR INTAKE														
	4-5/16" (109mm) OPTIONAL PLUMBING KIT														

ELECTRICAL (NO CORD, NO PLUG, DEDICATED CIRCUIT REQUIRED)								
MODEL	VOLTAGE	PH	HZ	AMPS	KW	BREAKER	AWG	CONNECTION
CTC10-20E	208 – 240	3	50/60	68.8 – 79.4	24.8 – 33.0	70-80	2 – 1	L1, L2, L3, G
	380 – 415	3	50/60	42.1 – 45.8	28.2 – 33.0	63	4 – 3	L1, L2, L3, N, G
	440 – 480	3*	50/60	36.4 – 39.7	28.3 – 33.0	40	6 – 4	L1, L2, L3, G

*ELECTRICAL SERVICE CHARGE APPLIES

WEIGHT	SHIP DIMENSIONS	PAN CAPACITY	PRODUCT MAXIMUM:
NET 760 lbs est 345 kg	(L x W x H) 56" x 49" x 65"	FULL-SIZE: 20" x 12" x 2-1/2"	240 lb (109 kg)
SHIP 805 lbs* 365 kg*	(1422 x 1245 x 1651mm)*	GN 1/1: 530 x 325 x 65mm	VOLUME MAXIMUM: 150 quarts (190 liters)
*DOMESTIC GROUND SHIPPING INFORMATION. CONTACT FACTORY FOR EXPORT WEIGHT AND DIMENSIONS.		GN 2/1: 650 x 530 x 65mm	**ON WIRE SHELVES ONLY. ADDITIONAL WIRE SHELVES REQUIRED FOR MAXIMUM CAPACITY
		**FULL-SIZE SHEET: 18" x 26" x 1"	

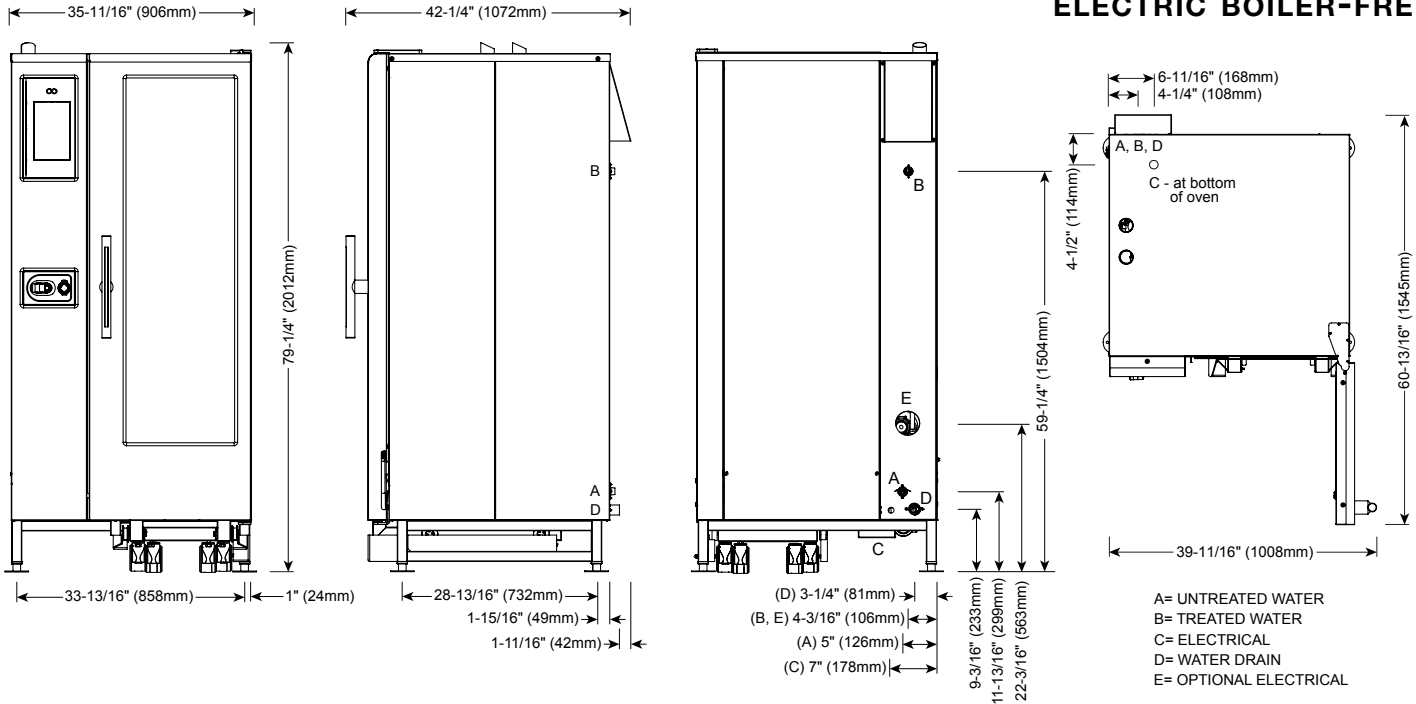

DIMENSIONS: H x W x D
EXTERIOR: 79-1/4" x 35-11/16" x 42-1/4" (2012mm x 906mm x 1072mm)
EXTERIOR WITH RECESSED DOOR: 79-1/4" x 40-11/16" x 42-1/4" (2012mm x 1033mm x 1072mm)
INTERIOR: 60-7/16" x 16-1/4" x 28-1/16" (1535mm x 411mm x 712mm)



WATER REQUIREMENTS	
TWO (2) COLD WATER INLETS - DRINKING QUALITY	
ONE (1) TREATED WATER INLET: 3/4" NPT*	* Both inlets can be from same 3/4" source. Divide using a manifold. Run one side through treatment device before running to oven.
ONE (1) UNTREATED WATER INLET: 3/4" NPT*	
LINE PRESSURE: 30 psi minimum dynamic and 90 psi maximum static (200 to 600 kPa)	
WATER DRAIN: 1-1/2" (40mm) CONNECTION WITH A VERTICAL VENT TO EXTEND ABOVE THE EXHAUST VENT. MATERIALS MUST WITHSTAND TEMPERATURES UP TO 200°F (93°C).	
CLEARANCE REQUIREMENTS	
LEFT: 0" (0mm)	18" (457mm) RECOMMENDED SERVICE ACCESS
RIGHT: 0" (0mm) NON-COMBUSTIBLE SURFACES	2" (51mm) DOOR SWING OR COMBUSTIBLE SURFACES
TOP: 20" (508mm) FOR AIR MOVEMENT	
BACK: 4" (102mm)	BOTTOM: 5-1/8" (130mm) FOR LEGS, AIR INTAKE
INSTALLATION REQUIREMENTS	
• Oven must be installed level. • Hood installation is required.	
• Water supply shut-off valve and back-flow preventer when required by local code.	

WATER QUALITY STANDARDS	
It is the sole responsibility of the owner/operator/purchaser of this equipment to verify that the incoming water supply is comprehensively tested and if required, a means of "water treatment" provided that would meet compliance requirements with the published water quality standards shown below. Non-compliance with these minimum standards will potentially damage this equipment and/or components and void the original equipment manufacturer's warranty. Alto-Shaam recommends using OptiPure® [www.optipurewater.com] products to properly treat your water.	
Contaminant	Inlet Water Requirements
Free Chlorine	Less than 0.1 ppm (mg/L)
Hardness	30-70 ppm
Chloride	Less than 30 ppm (mg/L)
pH	7.0 to 8.5
Silica	Less than 12 ppm (mg/L)
Total Dissolved Solids (tds)	50-125 ppm

ELECTRICAL - CTP20-10E (NO CORD, NO PLUG, DEDICATED CIRCUIT REQUIRED)										WITH COMBISMOKER® OPTION						
ECO STANDARD					**PROpower™ OPTION					ECO STANDARD			**PROpower™ OPTION			
VOLTAGE	PH	HZ	AWG	CONNECTION	AMPS	KW	BREAKER	AMPS	KW	BREAKER	AMPS	KW	BREAKER	AMPS	KW	BREAKER
208-240	3	50/60	1-1/0	L1, L2, L3, G	78.8-90.9	28.4-37.8	80-90	98.8-114	33.2-44.2	100-125	81.3-93.8	28.9-38.5	90-100	101.3-116.9	33.7-44.9	110-125
380-415	3	50/60	4-3	L1, L2, L3, N, G	48.2-52.5	32.3-37.8	63	60.5-65.8	37.1-44.2	63-80	50.9-55.4	32.8-38.5	63	63.1-68.7	37.7-44.9	100
440-480	3*	50/60	6-4	L1, L2, L3, G	41.7-45.5	32.4-37.8	50	52.2-57	37.2-44.2	60	43-46.9	32.9-38.5	50	53.6-58.5	37.8-44.9	60

*ELECTRICAL SERVICE CHARGE APPLIES **NO-COST OPTION ON ELECTRIC MODELS

WEIGHT	SHIP DIMENSIONS		PAN CAPACITY			
NET 905 lbs est 411 kg	(L x W x H) 56" x 45" x 87"		FULL-SIZE:	20" x 12" x 2-1/2"	Twenty (20)	PRODUCT MAXIMUM: 240 lb (109 kg)
SHIP 1052 lbs* 477 kg*	(1422 x 1143 x 2210mm)*		GN 1/1:	530 x 325 x 65mm	Twenty (20)	VOLUME MAXIMUM: 150 quarts (190 liters)
*DOMESTIC GROUND SHIPPING INFORMATION. CONTACT FACTORY FOR EXPORT WEIGHT AND DIMENSIONS.			**HALF-SIZE SHEET:	18" x 13" x 1"	Twenty (20)	**ON WIRE SHELVES ONLY. ADDITIONAL WIRE SHELVES REQUIRED FOR MAXIMUM CAPACITY

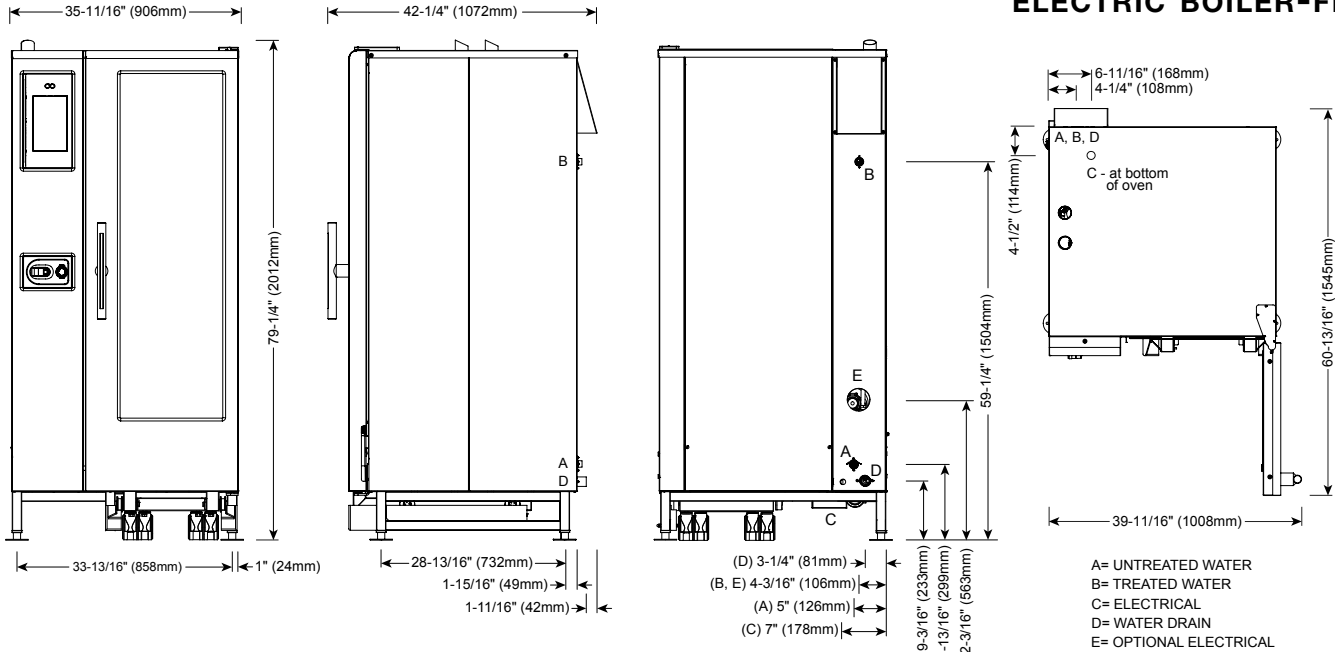

DIMENSIONS: H x W x D
EXTERIOR: 79-1/4" x 35-11/16" x 42-1/4" (2012mm x 906mm x 1072mm)
EXTERIOR WITH RECESSED DOOR: 79-1/4" x 40-11/16" x 42-1/4" (2012mm x 1033mm x 1072mm)
INTERIOR: 60-7/16" x 16-1/4" x 28-1/16" (1535mm x 411mm x 712mm)

WATER REQUIREMENTS	
TWO (2) COLD WATER INLETS - DRINKING QUALITY	
ONE (1) TREATED WATER INLET: 3/4" NPT*	* Both inlets can be from same 3/4" source. Divide using a manifold. Run one side through treatment device before running to oven.
ONE (1) UNTREATED WATER INLET: 3/4" NPT*	
LINE PRESSURE: 30 psi minimum dynamic and 90 psi maximum static (200 to 600 kPa)	
WATER DRAIN: 1-1/2" (40mm) CONNECTION WITH A VERTICAL VENT TO EXTEND ABOVE THE EXHAUST VENT. MATERIALS MUST WITHSTAND TEMPERATURES UP TO 200°F (93°C).	
CLEARANCE REQUIREMENTS	
LEFT: 0" (0mm)	18" (457mm) RECOMMENDED SERVICE ACCESS
RIGHT: 0" (0mm) NON-COMBUSTIBLE SURFACES	2" (51mm) DOOR SWING OR COMBUSTIBLE SURFACES
TOP: 20" (508mm) FOR AIR MOVEMENT	
BACK: 4" (102mm)	BOTTOM: 5-1/8" (130mm) FOR LEGS, AIR INTAKE
4-5/16" (109mm) OPTIONAL PLUMBING KIT	
INSTALLATION REQUIREMENTS	
• Oven must be installed level. • Hood installation is required.	
• Water supply shut-off valve and back-flow preventer when required by local code.	

WATER QUALITY STANDARDS	
It is the sole responsibility of the owner/operator/purchaser of this equipment to verify that the incoming water supply is comprehensively tested and if required, a means of "water treatment" provided that would meet compliance requirements with the published water quality standards shown below. Non-compliance with these minimum standards will potentially damage this equipment and/or components and void the original equipment manufacturer's warranty. Alto-Shaam recommends using OptiPure® [www.optipurewater.com] products to properly treat your water.	
Contaminant	Inlet Water Requirements
Free Chlorine	Less than 0.1 ppm (mg/L)
Hardness	30-70 ppm
Chloride	Less than 30 ppm (mg/L)
pH	7.0 to 8.5
Silica	Less than 12 ppm (mg/L)
Total Dissolved Solids (tds)	50-125 ppm

ELECTRICAL (NO CORD, NO PLUG, DEDICATED CIRCUIT REQUIRED)								
MODEL	VOLTAGE	PH	HZ	AMPS	kW	BREAKER	AWG	CONNECTION
CTC20-10E	208 – 240	3	50/60	78.8 – 90.9	28.4 – 37.8	80-90	1 – 1/0	L1, L2, L3, G
	380 – 415	3	50/60	48.2 – 52.5	32.3 – 37.8	63	4 – 3	L1, L2, L3, N, G
	440 – 480	3*	50/60	41.7 – 45.5	32.4 – 37.8	50	6 – 4	L1, L2, L3, G

*ELECTRICAL SERVICE CHARGE APPLIES

WEIGHT		SHIP DIMENSIONS		PAN CAPACITY		
NET	905 lbs est 411 kg	(L x W x H)	56" x 45" x 87"	FULL-SIZE:	20" x 12" x 2-1/2"	Twenty (20)
SHIP	1052 lbs* 477 kg*		(1422 x 1143 x 2210mm)*	GN 1/1:	530 x 325 x 65mm	Twenty (20)
*DOMESTIC GROUND SHIPPING INFORMATION. CONTACT FACTORY FOR EXPORT WEIGHT AND DIMENSIONS.				**HALF-SIZE SHEET:	18" x 13" x 1"	Twenty (20)
						PRODUCT MAXIMUM: 240 lb (109 kg)
						VOLUME MAXIMUM: 150 quarts (190 liters)
						**ON WIRE SHELVES ONLY. ADDITIONAL WIRE SHELVES REQUIRED FOR MAXIMUM CAPACITY

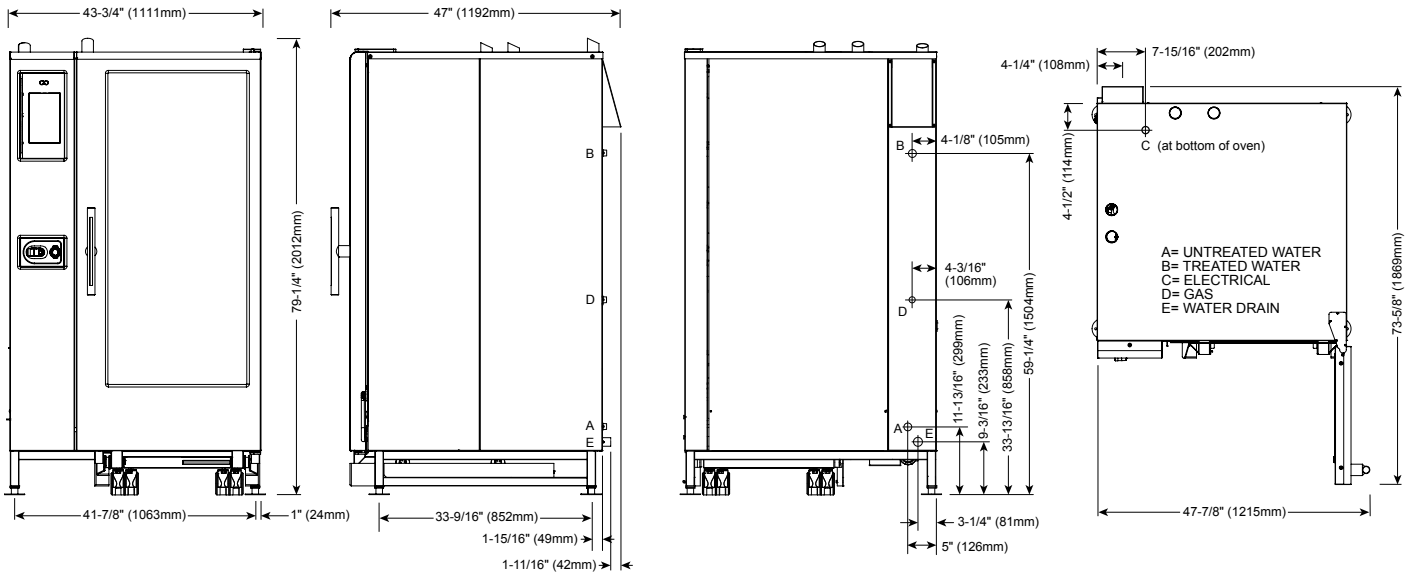

DIMENSIONS: H x W x D	
EXTERIOR:	79-1/4" x 43-3/4" x 47" (2012mm x 1111mm x 1192mm)
EXTERIOR WITH RECESSED DOOR:	79-1/4" x 48-3/4" x 47" (2012mm x 1238mm x 1192mm)
INTERIOR:	60-7/16" x 24-1/4" x 32-3/4" (1535mm x 616mm x 832mm)

WATER REQUIREMENTS	
TWO (2) COLD WATER INLETS - DRINKING QUALITY	
ONE (1) TREATED WATER INLET: 3/4" NPT*	*Both inlets can be from same 3/4" source. Divide using a manifold. Run one side through treatment device before running to oven.
ONE (1) UNTREATED WATER INLET: 3/4" NPT*	
LINE PRESSURE: 30 psi minimum dynamic and 90 psi maximum static (200 to 600 kPa)	
WATER DRAIN: 1-1/2" (40mm) CONNECTION WITH A VERTICAL VENT TO EXTEND ABOVE THE EXHAUST VENT. MATERIALS MUST WITHSTAND TEMPERATURES UP TO 200°F (93°C).	
CLEARANCE REQUIREMENTS	
LEFT: 0" (0mm)	18" (457mm) RECOMMENDED SERVICE ACCESS
RIGHT: 0" (0mm) NON-COMBUSTIBLE SURFACES	2" (51mm) DOOR SWING OR COMBUSTIBLE SURFACES
TOP: 20" (508mm) FOR AIR MOVEMENT	
BACK: 4" (102mm) 4-5/16" (109mm) OPTIONAL PLUMBING KIT	BOTTOM: 5-1/8" (130mm) FOR LEGS, AIR INTAKE
INSTALLATION REQUIREMENTS	
• Oven must be installed level. • Hood installation is required.	
• Water supply shut-off valve and back-flow preventer when required by local code.	

WATER QUALITY STANDARDS	
It is the sole responsibility of the owner/operator/purchaser of this equipment to verify that the incoming water supply is comprehensively tested and if required, a means of "water treatment" provided that would meet compliance requirements with the published water quality standards shown below. Non-compliance with these minimum standards will potentially damage this equipment and/or components and void the original equipment manufacturer's warranty. Alto-Shaam recommends using OptiPure® [www.optipurewater.com] products to properly treat your water.	
Contaminant	Inlet Water Requirements
Free Chlorine	Less than 0.1 ppm (mg/L)
Hardness	30-70 ppm
Chloride	Less than 30 ppm (mg/L)
pH	7.0 to 8.5
Silica	Less than 12 ppm (mg/L)
Total Dissolved Solids (tds)	50-125 ppm

ELECTRICAL - CTP20-20E (NO CORD, NO PLUG, DEDICATED CIRCUIT REQUIRED)										WITH COMBISMOKER® OPTION						
					ECO STANDARD			**PROpower™ OPTION			ECO STANDARD			**PROpower™ OPTION		
VOLTAGE	PH	HZ	AWG	CONNECTION	AMPS	kW	BREAKER	AMPS	kW	BREAKER	AMPS	kW	BREAKER	AMPS	kW	BREAKER
208-240	3	50/60	4/0	L1, L2, L3, G	137.6-158.8	49.6-66	150-175	172-198.5	57.8-77	175-200	140.1-161.6	50.1-66.7	150-175	174.5-201.3	58.4-77.7	200-225
380-415	3	50/60	1-1/0	L1, L2, L3, N, G	84.2-91.7	56.4-66	100	105.3-114.6	64.7-77	125	86.9-94.5	56.9-66.7	100	107.9-117.5	65.3-77.7	150
440-480	3*	50/60	2-1	L1, L2, L3, G	72.7-79.4	56.5-66	80	90.9-99.2	64.8-77	100	74.1-80.8	57.1-66.7	80-90	92.3-100.7	65.4-77.7	100

*ELECTRICAL SERVICE CHARGE APPLIES

**NO-COST OPTION ON ELECTRIC MODELS

WEIGHT			SHIP DIMENSIONS			PAN CAPACITY		
NET	1100 lbs est	499 kg	(L x W x H) 53" x 53" x 87** (1346 x 1346 x 2210mm)*			FULL-SIZE:	20" x 12" x 2-1/2"	Forty (40)
SHIP	1157 lbs*	525 kg*				GN 1/1:	530 x 325 x 65mm	Forty (40)
*DOMESTIC GROUND SHIPPING INFORMATION. CONTACT FACTORY FOR EXPORT WEIGHT AND DIMENSIONS.						GN 2/1:	650 x 530 x 65mm	Twenty (20)
						**FULL-SIZE SHEET:	18" x 26" x 1"	Twenty (20)
						PRODUCT MAXIMUM: 480 lb (218 kg)		
						VOLUME MAXIMUM: 300 quarts (380 liters)		
						**ON WIRE SHELVES ONLY. ADDITIONAL WIRE SHELVES REQUIRED FOR MAXIMUM CAPACITY		

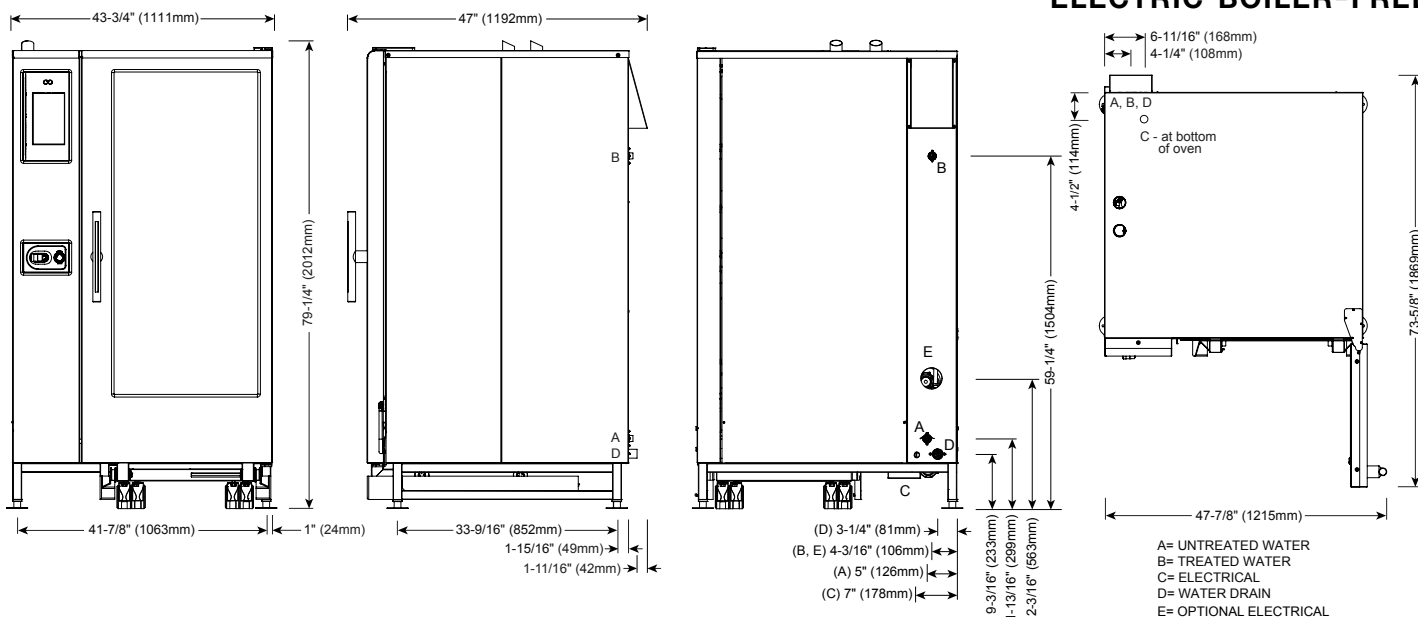

DIMENSIONS: H x W x D	
EXTERIOR:	79-1/4" x 43-3/4" x 47" (2012mm x 1111mm x 1192mm)
EXTERIOR WITH RECESSED DOOR:	79-1/4" x 48-3/4" x 47" (2012mm x 1238mm x 1192mm)
INTERIOR:	60-7/16" x 24-1/4" x 32-3/4" (1535mm x 616mm x 832mm)



WATER REQUIREMENTS	
TWO (2) COLD WATER INLETS - DRINKING QUALITY	
ONE (1) TREATED WATER INLET: 3/4" NPT*	* Both inlets can be from same 3/4" source. Divide using a manifold. Run one side through treatment device before running to oven.
ONE (1) UNTREATED WATER INLET: 3/4" NPT*	
LINE PRESSURE: 30 psi minimum dynamic and 90 psi maximum static (200 to 600 kPa)	
WATER DRAIN: 1-1/2" (40mm) CONNECTION WITH A VERTICAL VENT TO EXTEND ABOVE THE EXHAUST VENT. MATERIALS MUST WITHSTAND TEMPERATURES UP TO 200°F (93°C).	
CLEARANCE REQUIREMENTS	
LEFT: 0" (0mm)	18" (457mm) RECOMMENDED SERVICE ACCESS
RIGHT: 0" (0mm) NON-COMBUSTIBLE SURFACES	2" (51mm) DOOR SWING OR COMBUSTIBLE SURFACES
TOP: 20" (508mm) FOR AIR MOVEMENT	
BACK: 4" (102mm) 4-5/16" (109mm) OPTIONAL PLUMBING KIT	BOTTOM: 5-1/8" (130mm) FOR LEGS, AIR INTAKE
INSTALLATION REQUIREMENTS	
• Oven must be installed level. • Hood installation is required.	
• Water supply shut-off valve and back-flow preventer when required by local code.	

WATER QUALITY STANDARDS	
It is the sole responsibility of the owner/operator/purchaser of this equipment to verify that the incoming water supply is comprehensively tested and if required, a means of "water treatment" provided that would meet compliance requirements with the published water quality standards shown below. Non-compliance with these minimum standards will potentially damage this equipment and/or components and void the original equipment manufacturer's warranty. Alto-Shaam recommends using OptiPure® [www.optipurewater.com] products to properly treat your water.	
Contaminant	Inlet Water Requirements
Free Chlorine	Less than 0.1 ppm (mg/L)
Hardness	30-70 ppm
Chloride	Less than 30 ppm (mg/L)
pH	7.0 to 8.5
Silica	Less than 12 ppm (mg/L)
Total Dissolved Solids (tds)	50-125 ppm

ELECTRICAL (NO CORD, NO PLUG, DEDICATED CIRCUIT REQUIRED)									
MODEL	VOLTAGE	PH	HZ	AMPS	kW	BREAKER	AWG	CONNECTION	
CTC20-20E	208 – 240	3	50/60	137.6 – 158.8	49.6 – 66	150-175	4/0	L1, L2, L3, G	
	380 – 415	3	50/60	84.2 – 91.7	56.4 – 66	100	1 – 1/0	L1, L2, L3, N, G	
	440 – 480	3*	50/60	72.7 – 79.4	56.5 – 66	80	2 – 1	L1, L2, L3, G	

*ELECTRICAL SERVICE CHARGE APPLIES

WEIGHT		SHIP DIMENSIONS		PAN CAPACITY			PRODUCT MAXIMUM: 480 lb (218 kg)	
NET	1100 lbs est 499 kg	(L x W x H) 53" x 53" x 87**		FULL-SIZE:	20" x 12" x 2-1/2"	Forty (40)	VOLUME MAXIMUM: 300 quarts (380 liters)	
SHIP	1157 lbs* 525 kg*	(1346 x 1346 x 2210mm)*		GN 1/1:	530 x 325 x 65mm	Forty (40)	**ON WIRE SHELVES ONLY. ADDITIONAL WIRE SHELVES REQUIRED FOR MAXIMUM CAPACITY	
*DOMESTIC GROUND SHIPPING INFORMATION. CONTACT FACTORY FOR EXPORT WEIGHT AND DIMENSIONS.				GN 2/1:	650 x 530 x 65mm	Twenty (20)		
				*FULL-SIZE SHEET:	18" x 26" x 1"	Twenty (20)		

SITE INSTALLATION

WARNING

To prevent serious injury, death, or property damage:

- **Always** keep appliance on top of a pallet when using a fork lift or a pallet lift truck to move appliance.
- **Always** use a sufficient number of trained and experienced workers to place the appliance on floor, stand, or counter.

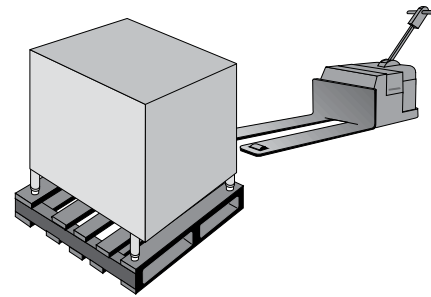
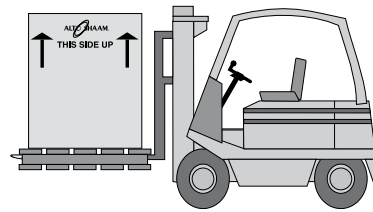

INSTALLATION

To ensure proper operation, the installation of this oven must be completed by qualified technicians in accordance with the instructions provided in this manual. Failure to follow the instructions provided may result in damage to the oven, building, or cause personal injury to personnel.

NOTICE: To prevent PROPERTY DAMAGE: Check the dimensions of the doorways and aisles before attempting to move the oven and pallet to the installation site.

Do not tilt the oven. Transport the oven in an upright and level position only.

Slide the preheat strip into place before using a forklift or pallet jack in between the trolley guides to avoid damaging the preheat strip when lifting.

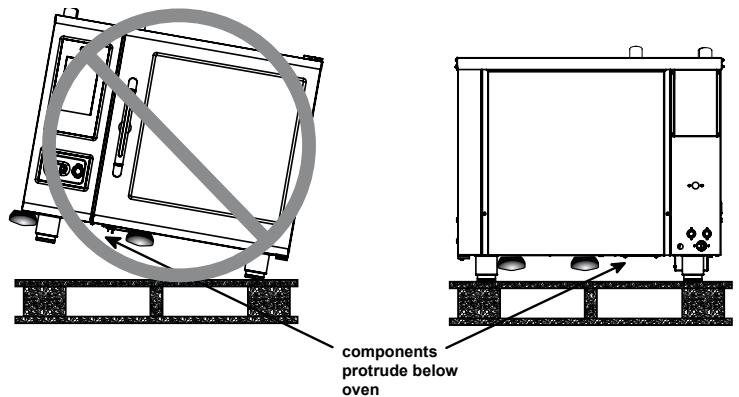

LIFTING INSTRUCTIONS

Remove banding before lifting. **Lift the unit from the front only, never from the side.**

Adjust the forks so that they do not damage any of the components under the unit. **Note that the control side of the oven is the heaviest portion.** Lift the unit just high enough to remove the wooden pallet. Lower the unit as close to the floor as possible and no more than 2" (50mm) above the floor. Secure hoses and dangling cords to avoid tangling or damage. **When moving the unit, drive slowly, keep it low to the ground, and use extreme caution.**

DEPTH OF FORKS IS CRITICAL FOR UNITS EQUIPPED WITH GREASE COLLECTION TO AVOID DAMAGING THE PUMP

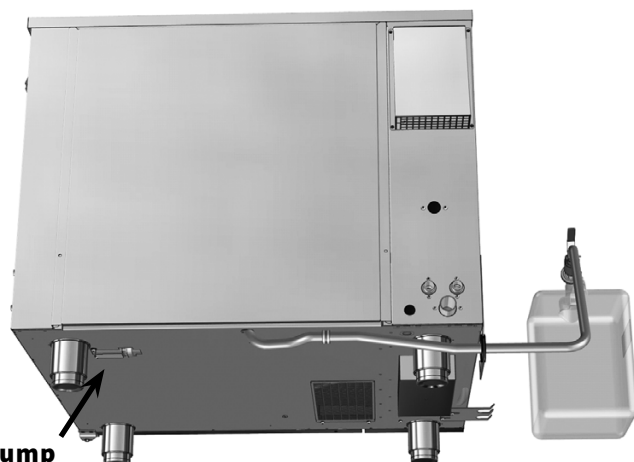

SITE INSTALLATION

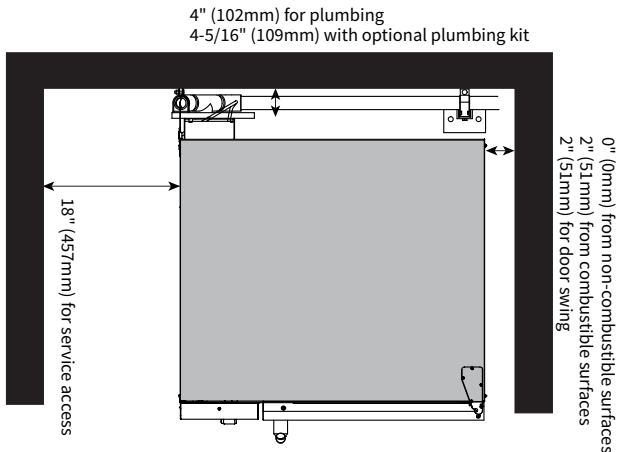

MINIMUM CLEARANCE REQUIREMENTS	
LEFT SIDE	0" (0mm) MINIMUM 18" (457mm) RECOMMENDED SERVICE ACCESS
RIGHT SIDE	0" (0mm) FROM NON-COMBUSTIBLE SURFACES 2" (51mm) FROM COMBUSTIBLE SURFACES 2" (51mm) FOR DOOR SWING
BACK	4" (102mm) FOR PLUMBING 4-5/16" (109mm) FOR OPTIONAL PLUMBING KIT
TOP	20" (508mm) FOR AIR MOVEMENT
BOTTOM	5-1/8" (457mm) FOR LEGS AND UNOBSTRUCTED AIR INTAKE

NOTICE: • A minimum distance of 18" (457mm) is strongly recommended for service access. If adequate service clearance is not provided, it will be necessary to disconnect the gas, water, and drain to move the oven with a fork lift for service access. Service charges in connection with inadequate service access is not covered under warranty.

- Do not install a stacked combination directly over a drain. Steam rising up out of the drain will adversely affect operation, hamper cooling air circulation, and may damage electrical and electronic components. Failure to do so will void the warranty. A single oven installed on a stand with solid surface bottom shelf can be positioned over a drain since the solid surface will block the rising steam.

POSITIONING ON SITE - COUNTERTOP

Place the oven on a stable, non-combustible level horizontal surface. Use the adjustable feet to overcome an uneven floor and ensure that the unit is level.

It is strongly recommended that table top models be mounted on a factory supplied stand or a stand that is stable, open, and level. The adjustable oven legs should be extended beyond the depth of the positioning ring to allow for leveling after the oven has been placed on the stand.

Each of the legs on the stand and the oven can be adjusted 2" (51mm) up or down.

Level the oven from front-to-back and side-to-side by means of the adjustable legs. Components within the oven condenser tank are sensitive to pitch and can be damaged. The tolerance to level is +/- .125". If this tolerance range is not achievable, the floor must be repaired to obtain level.

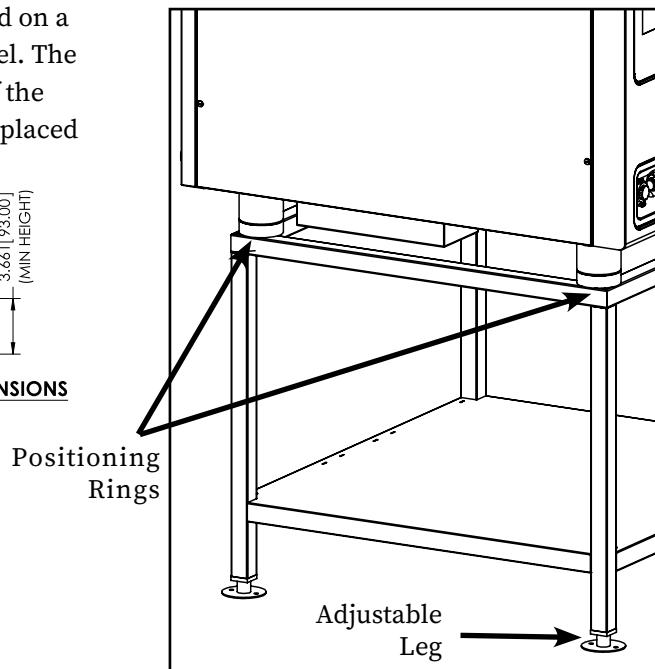
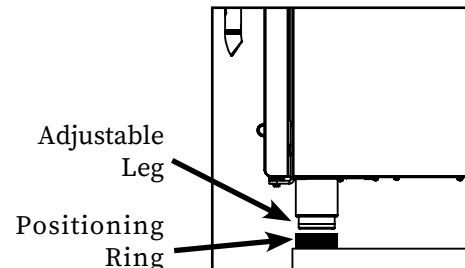
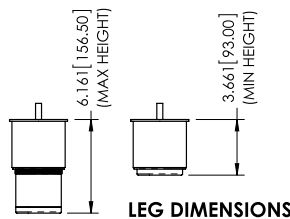
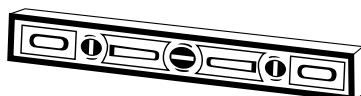

SITE INSTALLATION

POSITIONING ON SITE — 20-10 & 20-20 MODELS

Place the oven on a stable, non-combustible level horizontal surface. Use the adjustable feet to overcome an uneven floor and ensure that the unit is level.

1. Once the unit has been positioned properly beneath a ventilation hood system, adjust the four outside feet located on the outside corners of the base frame. Begin with a 32mm (1.25") height (illustration 1) leveling the oven from side-to-side and front-to-back (illustration 2).
2. Roll the trolley into the oven and check the overall fit of the trolley. Close the door and check fit. Make adjustments as needed.

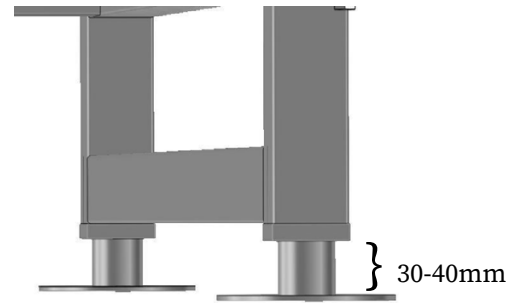
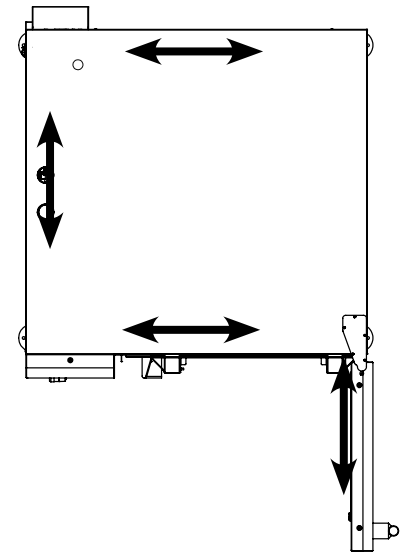

Illustration 1

Illustration 2



NOTICE: Adjustable measurements are from the top of the leg flange to the bottom of the leg square frame (see illustration 1). If measurements exceed 40mm in height or trolley is not on a level and stable horizontal floor, the following may occur:

- Improper sealing of the door sweep gasket to the trolley plate, or heat strip.
- Trolley may not fit properly.

SITE INSTALLATION**⚠ CAUTION**

Power source must match voltage identified on appliance rating tag. The rating tag provides essential technical information required for any appliance installation, maintenance or repairs. Do not remove, damage or modify the rating tag.

⚠ WARNING

To prevent serious injury, death, or property damage:

All electrical connections must be made by a qualified and trained service technician in accordance with applicable electrical codes.



This appliance must be adequately grounded in accordance with local electrical codes or, in the absence of local codes, with the current edition of the National Electrical Code ANSI/NFPA No. 70. In Canada, all electrical connections are to be made in accordance with CSA C22.1, Canadian Electrical Code Part 1 or local codes.



CE-approved appliances include an equipotential-bonding terminal marked with the symbol shown on the left. Provisions for earthing are to be made in accordance with IEC:2010 60335-1 section 27 or local codes.

⚠ WARNING

Appliances without a cord provided by the factory must be equipped with a cord of sufficient length to permit the appliance to be moved for cleaning.

Always use the correct AWG wire size based on the electrical requirements for the appliance.

⚠ WARNING

Improper installation, alteration, adjustment, service, cleaning, or maintenance could result in property damage, severe injury, or death.

Read and understand the installation, operating and maintenance instructions thoroughly before installing, servicing, or operating this equipment.

⚠ WARNING

Electric shock hazard.

Perform lockout/tagout procedures before cleaning or servicing this appliance.

ELECTRICAL CONNECTION

ELECTRICAL CONNECTION FOR GAS MODELS

- 1. An electrical wiring diagram is located behind the control panel on the left side of the oven.** This appliance must be branch circuit protected with proper ampacities, in accordance with the wiring diagram.
- For 1-phase applications, the ground fault or residual current protection device must accommodate a leakage current of 20 mA.
- Wire size for the main incoming power to the unit must match the minimum size listed in the specifications applicable to the specific oven model. For supply connections, locate the wire size posted on the label located on the electrical control box cover, behind the service panel.
- Before operating the oven, check all cable connections and electrical terminal connections in the electrical connection area for tightness since connections can loosen during transport.

NOTICE: Check motor rotation on the Combitherm® CT Classic CTC model line. Arrows on the motor housing indicate proper rotation.

- After both water and electrical connections have been completed on all Combitherm model types, operate the oven in any cooking mode for a period of 15 minutes.
- Recheck the main power connections at the terminal block, cable connections, and electrical terminal connections to make certain they remain tight.

ELECTRICAL CONNECTION FOR ELECTRIC MODELS

NOTICE: All models must be equipped with a country certified external allpole disconnection switch with sufficient contact separation.

An oil resistant cord like H05RN or H07RN or equivalent must be used.

- 1. An electrical wiring diagram is located behind the control panel on the left side of the oven.** This appliance must be branch circuit protected with proper ampacities, in accordance with the wiring diagram.
- Wire size for the main incoming power to the unit must match the minimum size listed in the specifications applicable to the specific oven model. For supply connections, locate the wire size posted on the label located on the electrical control box cover, behind the service panel.
- Before operating the oven, check all cable connections and electrical terminal connections in the electrical connection area for tightness since connections can loosen during transport.

NOTICE: Check motor rotation on the Combitherm® CT Classic CTC model line. Arrows on the motor housing indicate proper rotation.

- After both water and electrical connections have been completed on all Combitherm model types, operate the oven in any cooking mode for a period of 15 minutes.
- Recheck the main power connections at the terminal block, cable connections, and electrical terminal connections to make certain they remain tight.

ELECTRICAL KIT INSTALLATION – 50 Hz

International Applications

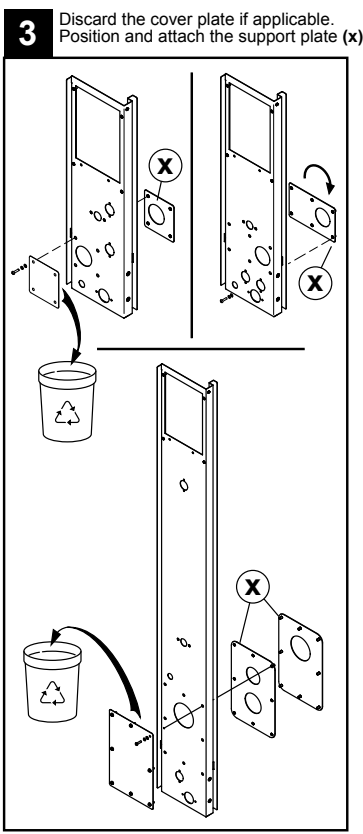
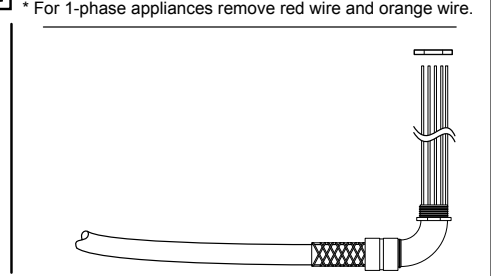
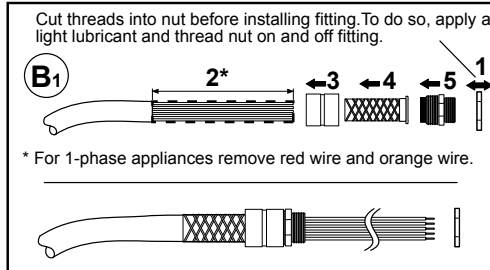
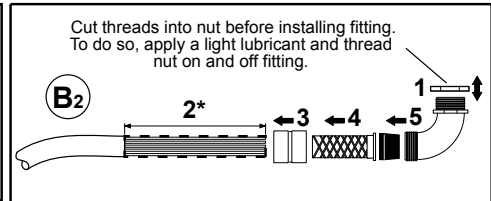
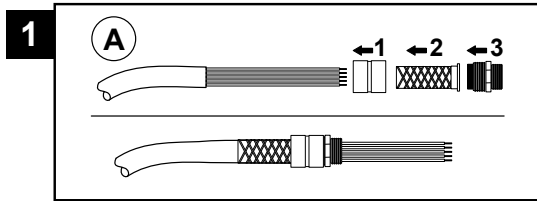
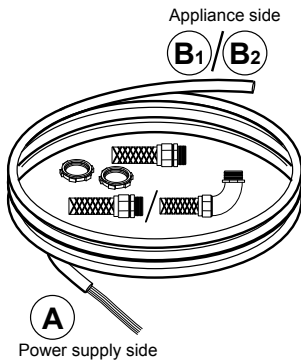

2 Remove enough cable covering so that wires reach the terminal strip. Depending on the application, install the straight or elbow fitting to the cable.

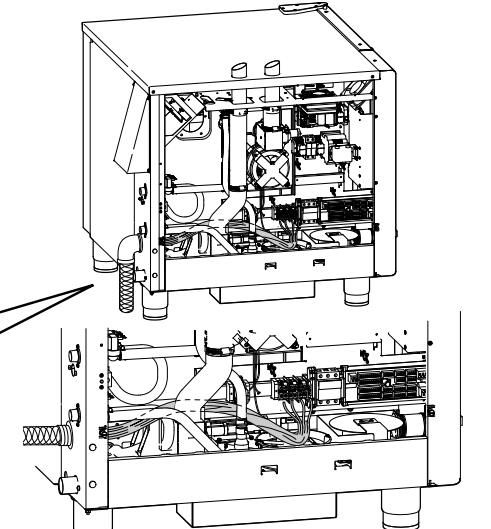
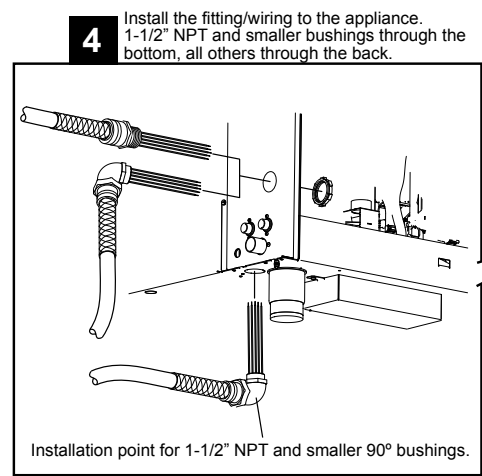

5 Route the wires. Keep wires away from hot surfaces such as: water tank, drain pipe, motor, edges of sheet metal, vent pipes, or other appliances.

6 Strip the wires, then connect them to the terminal strip. Note: Illustrations are representative only. Your appliance may vary.

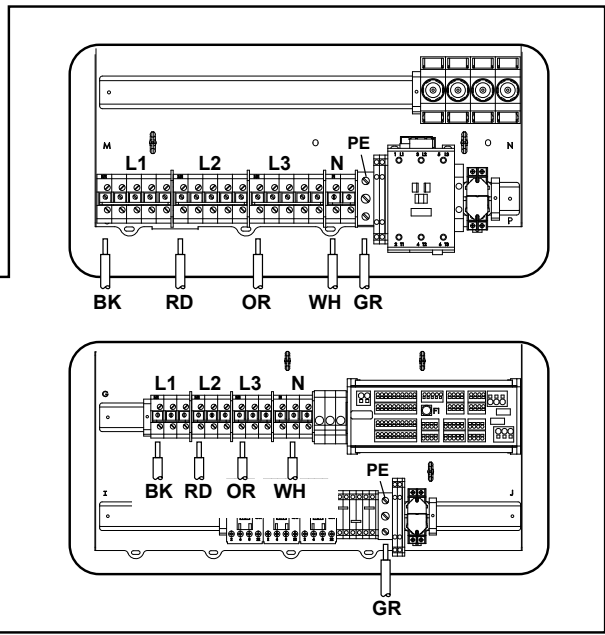
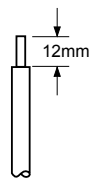
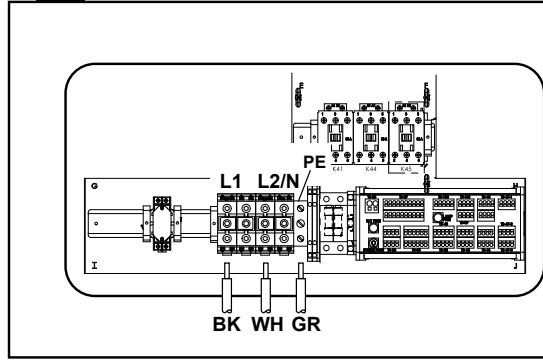

ELECTRICAL KIT INSTALLATION - 60 Hz

Applications for the Americas

Note: Cabling and connectors must be supplied for 120V configurations.

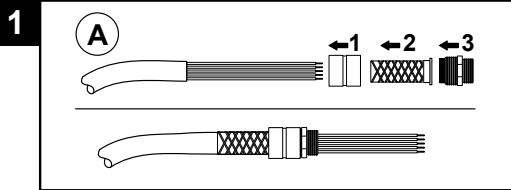
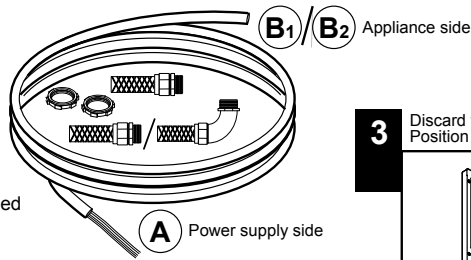

2 Remove enough cable covering so that wires reach the terminal strip. Depending on the application, install the straight or elbow fitting to the cable.

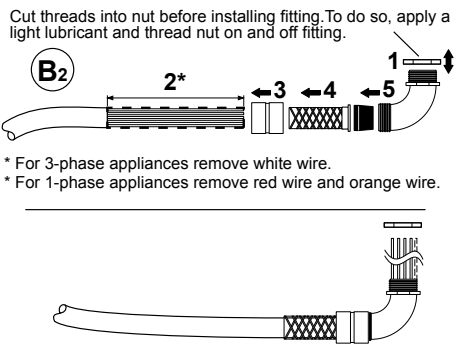
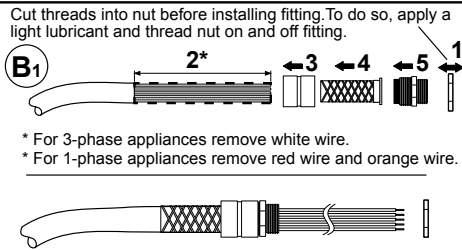

3 Discard the cover plate if applicable. Position and attach the support plate (x).

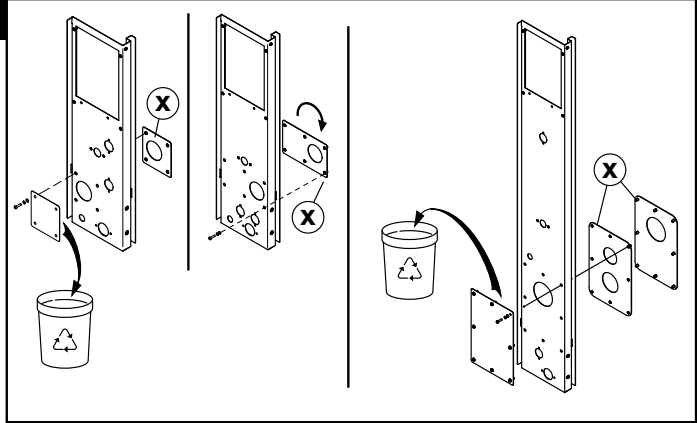

4 Install the fitting/wiring to the appliance. 1-1/2" NPT and smaller bushings through the bottom, all others through the back.

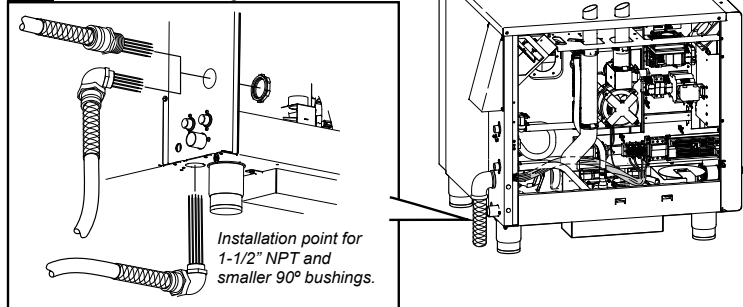

5 Route the wires. Keep wires away from hot surfaces such as water tank, drain pipe, motor, edges of sheet metal, vent pipes, or other appliances.

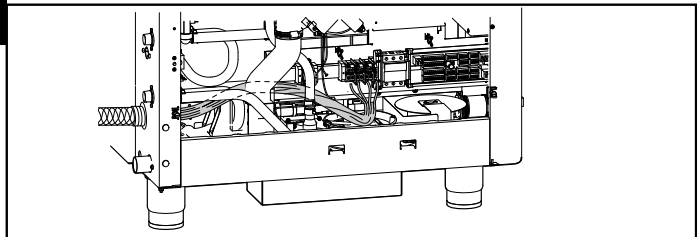

6 Strip the wires, then connect them to the terminal strip. Note: Illustrations are representative only. Your appliance may vary.

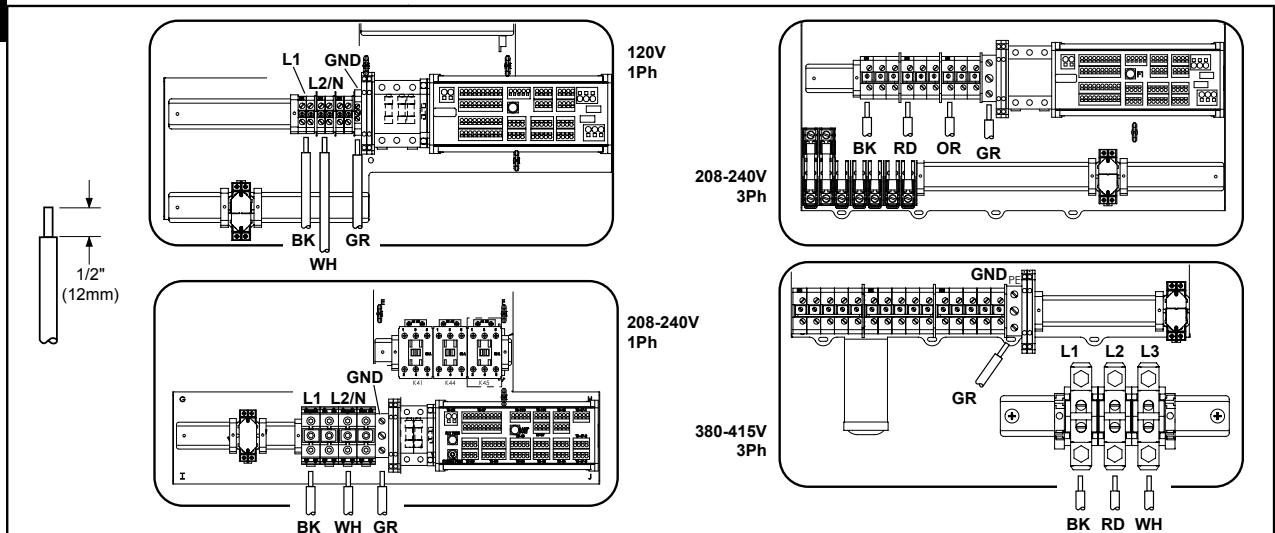

VENTILATION REQUIREMENTS FOR GAS MODELS

WARNING

To prevent **SERIOUS INJURY, DEATH, or PROPERTY DAMAGE:**

Installation, air adjustment and/or service work must be in accordance with all local codes and must be performed by a trained service technician qualified to work on gas appliances.

1. A single gas Combitherm oven requires a minimum of 28 CFM make-up air for both natural and propane gas. The bottom of the oven allows necessary air flow into the appliance necessary for gas combustion and must be kept clear at all times.



DO NOT obstruct or restrict ventilation nor the air flow required to support combustion.

2. It is especially critical that gas supply piping and electrical support cord and/or receptacle be routed away from the path of the hot combustion fumes.
3. Make certain the oven installation maintains adequate air ventilation to provide cooling for electrical and gas components. The area around the oven should be clear of any obstructions which might retard the flow of cooling air. Failure to observe this caution may result in damage to the components and will void the warranty.
4. This oven cannot be direct vented.
5. Install the oven under a ventilation hood meeting all applicable code requirements. Combustion fumes must be vented in accordance with local, state, or national codes.

NOTICE

Inadequate ventilation, or failure to ensure an adequate air flow may result in high ambient temperatures at the rear of the appliance. High ambient temperatures can cause the thermal-overload protection device on the blower motor to trip resulting in severe damage to the blower motor.

An adequate ventilation system is required for commercial cooking equipment. The minimum ventilation system shall comply with local regulations and relevant codes. In the absence of local codes, the ventilation system shall comply with:

- USA and Canada: NFPA 96
- EU: EN203
- Australia/New Zealand: AS 1668.1 and AS 1668.2

The oven must be installed under a ventilation hood listed to ANSI/UL 705 (latest edition).

WARNING

DO NOT obstruct or block exhaust flues or attach any flue extension that may impede proper burner operation, restrict the exhaust fumes and cause negative backdraft or the appliance to shut down. Failure to do so may result in serious injury or death.

WARNING

Failure to properly vent this appliance may cause **SERIOUS INJURY, DEATH, or PROPERTY DAMAGE**. The formation of volatile substances may cause suffocation, equipment damage, operational problems and unsatisfactory cooking performance as a consequence of improper venting and is not covered by your warranty.

Ventilation hoods and exhaust systems shall be permitted to be used to vent appliances installed in commercial applications.

In accordance with NFPA 54 for the Commonwealth of Massachusetts only:

Where automatically operated appliances are vented through a ventilation hood or exhaust system equipped with a damper or with a power means of exhaust, provisions shall be made to allow the flow of gas to the main burners only when the damper is open to a position to properly vent the appliance and when the power means of exhaust is in operation.

GAS SUPPLY AND INSTALLATION

WARNING



To prevent SERIOUS INJURY or DEATH from fire or explosion:

Only connect the type of gas indicated on the identification nameplate. Your gas Combitherm® is equipped to operate using only the fuel type specified on the identification name plate. Should conversion from natural gas to propane or from propane to natural gas be desired, conversion parts must be ordered from Alto-Shaam. Conversions must be performed by an

Alto-Shaam authorized service provider only.

Always ensure the oven's nameplate reflects the intended fuel type for your oven.

Residential gas connections and hard-piped gas connections DO NOT meet NSF certifications and should NEVER be used with your Combitherm oven.

Please refer to model specifications for rated thermal loads and connected pressure requirements.

Natural	Cat	Gas Type
GR	II ₂ H3B/P	2H-G20-20mbar
CY	II ₂ H3B/P	2H-G20-20mbar
ES/FR/GB/IE/CH	II ₂ H3P	2H-G20-20mbar
AT	II ₂ H3B/P	2H-G20-20mbar
BE	II ₂ E(S)3B/P	2H-G20-20mbar
DE	II ₂ ELL3B/P	2E-G20/G25-20mbar
NL	II ₂ L3B/P	2L-G25-25mbar
Butane/Propane Mixture	Cat	Gas Type
GR	II ₂ H3B/P	3B/P-G30/G31-30mbar
CY	II ₂ H3B/P	3B/P-G30/G31-30mbar
ES/FR/GB/IE/CH	II ₂ H3P	3P-G31-30mbar
AT	II ₂ H3B/P	3B/P-G30/G31-50mbar
BE	II ₂ E(S)3P	3P-G31-30mbar
DE	II ₂ ELL3B/P	3B/P-G30/G31-50mbar
NL	II ₂ L3B/P	3B/P-G30/G31-30mbar
AUS/NZ	—	NGN 1.13 kPa
AUS/NZ	—	LPG-X Propane 2.75 kPa
Japan	—	Natural Gas 13A 1.96 kPa
Japan	—	LPG - Propane 2.8 kPa

Installation shall comply with local codes required for gas appliances. In the absence of local codes, installation shall comply with the latest edition of:

- USA: National Fuel Gas Code, ANSI Z223.1 (NFPA 54). And OSHA Regulations
- Canada: Natural Gas and Propane Installation Code, CAN/CSA-B149.1-15
- EU: European Standard EN203
- Australia/New Zealand: AS 5601

NOTICE: Connection components not supplied by Alto-Shaam must comply with the regulations in force of the country of use.

SEDIMENT TRAP REQUIRED:

A sediment trap shall be installed downstream of the appliance shutoff valve as close to the inlet of the appliance as practical at the time of appliance installation. The sediment trap shall be either a tee fitting with a capped nipple in the bottom outlet, as illustrated below or another device recognized as an effective sediment trap.

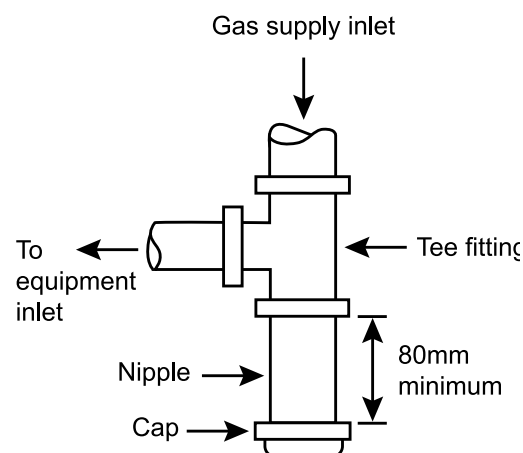

GAS SUPPLY AND INSTALLATION

WARNING

Improper installation, adjustment of burner pressures, alteration, service, maintenance, or use can cause carbon monoxide poisoning, explosion, fire, electrical shock, or other conditions which may cause **SERIOUS INJURY, DEATH or PROPERTY DAMAGE**. Consult a qualified and trained installer, service agency, local gas supplier, or your distributor for information or assistance. The qualified and trained installer or agency must use only factory-authorized and listed kits or accessories when modifying this appliance.

INSTALLATION REQUIREMENTS

GAS CONNECTION: 3/4" NPT

For Europe, gas connection thread fittings should conform to EN ISO 228-1, or ISO 7-1, or shall have a compression fitting.

If the appliance has casters, a restraint system must be installed. See section *Mobile Equipment Restraint*, page 53.

NOTE: If a flexible gas line is used, it must be AGA approved, commercial type and at least 3/4" I.D. or comply to European Standard EN203.

HOOD INSTALLATION IS REQUIRED

After installation, burner and gas valve should be checked and adjusted by a qualified and trained Alto-Shaam technician for proper operation and validate CO2 levels. **GAS VALVE MAY REQUIRE FIELD ADJUSTMENT ABOVE 2,000' (610m) AND IS NOT ADJUSTED AT THE FACTORY.**

GAS TRAIN - ORIFICE

When converting gas units to either propane or natural gas you will need to provide the corresponding orifice and restrictor plate, and new serial data tags, part numbers: LA-26348 and LA-26349

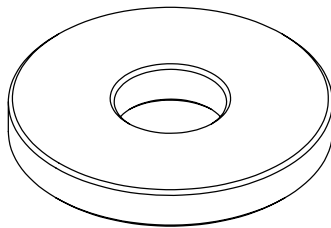

Item	Part	Description	Qty.
1	OR-35874	ORIFICE, GAS VALVE DISC 4.60mm, 6-10 G25, 10-20 G31, 20-20 G31	1
2	OR-35876	ORIFICE, GAS VALVE DISC 2.60mm, 6-10 G30	1
3	OR-35877	ORIFICE, GAS VALVE DISC 4.00mm, 10-10 G30, 20-10 G30, 7-20 G30	1
4	OR-35878	ORIFICE, GAS VALVE DISC 4.10mm, 10-10 G31, 20-10 G31, 10-20 G30, 20-20 G30	1
5	OR-35943	ORIFICE, GAS VALVE DISC 5.70mm, 10-10 G20, 20-10 G20, 10-20 G20, 20-20 G20	1
6	OR-36006	ORIFICE, GAS VALVE DISC 6.30mm, 7-20 G25	1
7	OR-36007	ORIFICE, GAS VALVE DISC 6.00mm, 10-10 G25, 20-10 G25	1
8	OR-36207	ORIFICE, GAS VALVE DISC 6.40mm, 10-20 G25, 20-20 G25	1
9	OR-36625	ORIFICE, GAS VALVE DISC 3.75mm, 6-10 G20	1
10	OR-36626	ORIFICE, GAS VALVE DISC 2.75mm, 6-10 G31	1
11	OR-36627	ORIFICE, GAS VALVE DISC 5.55mm, 7-20 G20	1
12	OR-36628	ORIFICE, GAS VALVE DISC 4.20mm, 7-20 G31	1

WARNING

Electric shock hazard.

Perform lockout/tagout procedures before cleaning or servicing this appliance.

NOTE: Natural Gas = G20
 Propane = G31
 Butane = G30
 Low Calorific Natural Gas = G25

GAS TRAIN - RESTRICTOR PLATE

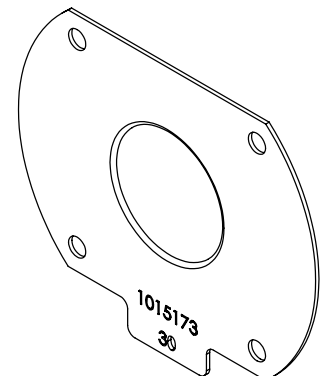

Item	Part	Description	Qty.
1	1012504	PLATE, RESTRICTOR COMBI, 20mm, 10-20 G30, 20-20 G30	1
2	1012817	PLATE, RESTRICTOR COMBI, 25mm, 7-20 G25	1
3	1013843	PLATE, RESTRICTOR COMBI, 14mm, 6-10	1
4	1013844	PLATE, RESTRICTOR COMBI, 21mm, 10-20 G25, 20-20 G25	1
5	1013845	PLATE, RESTRICTOR COMBI, 22mm, 10-20 G20, 10-20 G31, 20-20 G20, 20-20 G31	1
6	1014619	PLATE, RESTRICTOR COMBI, 17mm, 10-10 G31, 10-10 G30, 20-10 G31, 20-10 G30	1
7	1015074	PLATE, RESTRICTOR COMBI, 18mm, 10-10 G20, 10-10 G25, 20-10 G20, 20-10 G25	1
8	1015075	PLATE, RESTRICTOR COMBI, 23mm, 7-20 G31	1
9	1015076	PLATE, RESTRICTOR COMBI, 24mm, 7-20 G20, 7-20 G30	1

GAS SUPPLY AND INSTALLATION

WARNING



To prevent **SERIOUS INJURY, DEATH, or PROPERTY DAMAGE:**

Installation, air adjustment and/or service work must be in accordance with all local codes and must be performed by a trained service technician qualified to work on gas appliances.

Remove any tape or compound residue on all external thread connections before proceeding.

Use an approved gas pipe sealant at all external threaded connections, Gas piping used on gas

connections must avoid sharp bends that may restrict the flow of gas to the appliance. If the connected pressure exceeds 14.0" W.C. (3.5 kPa), a step-down regulator is required to be supplied by the owner/operator.

Close the individual manual shut-off valve to **isolate the appliance** from the gas supply piping system during any pressure testing at test pressures equal to or less than 1/2 psig. (3,4 kPa). The appliance and individual shut-off valve **must be disconnected** from the gas supply piping system during any pressure testing at pressures in excess of 1/2 psig. (3,4 kPa).

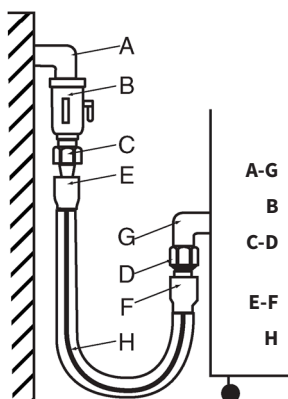
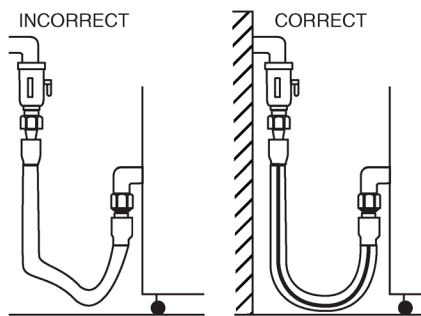

- GAS INTAKE**
- A-G Installation elbow
 - B Ball Valve
 - C-D Three-piece union fitting (minimum 1 per installation)
 - E-F End connector for the flexible tube
 - H Marking line

WARNING



To prevent personal injury, death or property damage:

Do not store or use gasoline or other flammable vapors or liquids in the vicinity of this or any other appliance.

WARNING



To prevent **SERIOUS INJURY, DEATH or PROPERTY DAMAGE:**

DO NOT spray aerosols in the vicinity of this appliance when in operation.

CAUTION



To prevent **INJURY or PROPERTY DAMAGE,** make certain the area around the appliance is kept clear of combustible items.

In the U.S.A., installation must conform to local codes or, in the absence of local codes, with the current edition of the **National Fuel Gas Code**, NFPA-54 and ANSI Z83.11a CSA 1.8a 2004 (or latest edition). In Canada, installation must be in accordance with local codes, CAN/CGA-B149.1, **Installation for Natural Gas Burning Appliances and Equipment** (latest edition) or CAN/CGAB149.2 **Installation for Propane Burning Appliances and Equipment** (latest edition). In Europe, installation must be in accordance with European Standard EN203.

The inlet supply line must be properly sized to accommodate all individual appliances simultaneously used on the same line but must never be smaller than 3/4" NPT.

GAS SUPPLY AND INSTALLATION

WARNING

To prevent SERIOUS INJURY, DEATH, or PROPERTY DAMAGE:

Always use proper length pipes to avoid stress on the gas control manifold.

Always use an approved gas pipe sealant at all external threaded connections.

Always remove any tape or compound residue on all external thread connections before installing appliance.

The minimum size requirement for gas piping or a flexible connector is 3/4 – inch (19mm). For long runs of gas piping, the pipe diameter must conform to the tables in the National Fuel Gas Code, ANSI/NFPA Z223.1 or European Standard EN203.

A listed gas shut-off valve must be installed upstream of the appliance to shut off the gas supply during servicing. The shut-off valve should be accessible with the appliance in the normal installation position.

If the oven or the oven stand is supplied with casters, gas connection must be made with a flexible connector that complies with the Standard for Connectors for Movable Gas Appliances, ANSI Z21.69; or in Canada, Connectors for Movable Gas Appliances, CAN/CGA-6.16-M87.

When using a flexible connector, a quick disconnect device must be used to comply with the Standard for Quick-Disconnect Devices for Gas Fuels, ANSI Z21.41; or in Canada, Quick Disconnect Devices for Use with Gas Fuels, CAN1-6.9 or European Standard EN203. In Australia / New Zealand AS 5601, AS 1869.

When a quick disconnect device and flexible connector are used, a restraining device must be installed to limit the movement of the appliance and prevent damage to the connector or quick disconnect. An example of a restraining device would consist of a 2000 pound test, stainless steel cable, attached to a structural member of the kitchen wall behind the oven. The means of attachment should consist of a quick connect snap so that the oven can be disconnected when the appliance must be moved away from the wall.

The other end of the cable should be permanently attached to the rear frame of the oven. The cable should be of sufficient length so that no strain is ever placed on the flexible gas connector in the event of accidental movement of the oven without properly disconnecting the gas connector. The flexible connector should be routed to form a downward “U” loop between the building gas supply and the permanent attachment at the rear of the oven.

The routing of the flexible connector must not run along the side of the exhaust stacks or cross the exhaust stacks. Oven temperatures achieved during operation are too hot for safe operation. Gas piping should be installed from the point of gas connection at the back of the oven and run away from the exhaust stacks where the flexible connector may be safely used. See the illustration for the area to avoid.

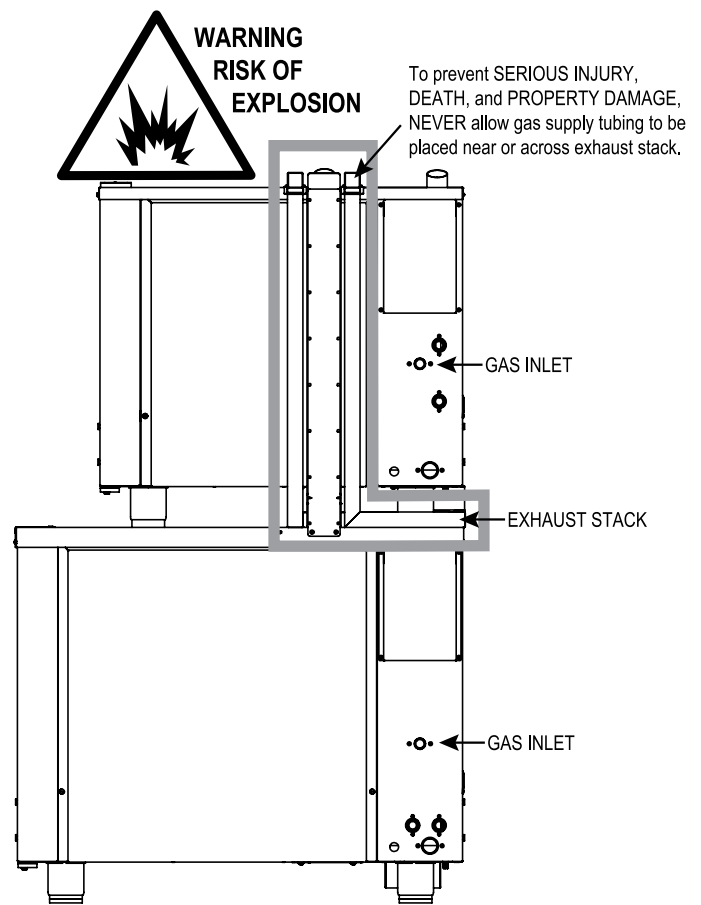

GAS SUPPLY AND INSTALLATION

GAS LEAK TESTING

If a pressure leak test above 1/2 psi (34.5 mbar) is to be performed on the building supply gas piping, the shut-off gas valve and oven inlet gas supply line must be disconnected from the building supply piping before conducting the pressure test. Failure to do so may result in damage to the manual gas valve, gas components in the oven, or both.

If any gas leak tests are to be conducted at pressures equal to or below 1/2 psi (34.5 mbar), the manual gas shut-off valve upstream of the oven must be turned off before conducting the tests.

Leak testing of the internal oven piping system was conducted before shipping the oven from the factory. If additional testing is needed, it should only be conducted at normal gas supply pressures. If the testing is performed using combustible gas in the piping, the leak checking should be done with a soap solution (bubble checking).

The use of an electronic combustible gas leak detector is helpful, however, this type of detector can be oversensitive. Electronic detectors may indicate false leaks from other sources which would not be detected when checking with a liquid solution to verify a no-hazard gas connection.

When starting the oven after initial installation, the gas lines must be free of air. It may take up to 30 minutes to eliminate all air from the lines. If, after this time there is no heat, call for factory assistance.

GAS EXHAUST

The oven is not designed for direct connection to a chimney vent system or for direct connection to a horizontal exhaust system.

The oven must be installed under a ventilation hood listed to ANSI/UL 705 (latest edition), and the installation must be completed in accordance with the ANSI/NFPA 96-1987, Standard for Ventilation Control and Fire Protection of Commercial Cooking Operations.

Oven operators should be instructed with regard to the hazards of placing any material on top of the oven that would obstruct the flow of flue products out the opening of the flue diverter. Operators should also be instructed with regard to the hazards of hot flue gases and that any material or items placed on top of, or in front of the flue deflector could be damaged or cause a fire hazard.

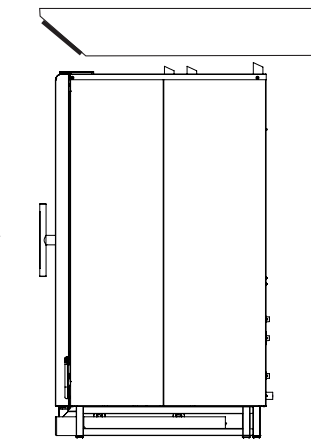

WARNING	
	Never use an open flame or other ignition sources to check for gas leakage. Failure to do so may cause a fire or explosion and result in serious injury or death.

DANGER	
	<p>Before starting the appliance, make certain you do not detect the odor of gas.</p> <p>If you smell gas:</p> <ul style="list-style-type: none">• Shut off the gas supply immediately.• Do not attempt to light any appliance.• Do not touch any electrical elements.• Extinguish any open flame.• Evacuate the area.• Use a telephone outside the property and immediately contact your gas supplier.• If unable to contact your gas supplier, contact the fire department.

WARNING	
	<p>DO NOT obstruct or block exhaust flues or attach any flue extension that may impede proper burner operation, restrict the exhaust fumes and cause negative backdraft or the appliance to shut down. Failure to do so may result in serious injury or death.</p>

WATER QUALITY REQUIREMENTS

Use a drinking quality, cold water supply only.

WARNING
Significant damage to the appliance cavity, elements, or heat exchanger could result from improper water quality. Failure to meet the water quality requirements and observe this precaution will void the warranty.

Water quality is of critical importance when installing steam producing equipment of any kind, particularly high temperature steam producing equipment. Water that is perfectly safe to drink is composed of chemical characteristics that directly affect the metal surfaces of steam producing equipment. These chemical characteristics differ greatly from region to region throughout the U.S. and the world. Varying combinations of pH; alkalinity; hardness; chlorides; total dissolved solids; and other chemical characteristics, when subjected to high temperatures, will cause water to have a tendency to either scale or corrode.

Alto-Shaam has consulted with people who understand the properties of water in order to provide water quality standards that meet the broadest possible range of acceptable water quality requirements to help protect your investment.

We strongly urge water testing to ascertain the water quality on site prior to the installation of any steam producing equipment. Since water quality is an important issue, Alto-Shaam is committed to provide as much information as possible to help protect the investment made in this equipment.

A water filtration system, when properly installed, maintained, and combined with the required levels of steam producing equipment maintenance, will help lessen the affect water has on metal surfaces. It will not, however, provide complete protection against all water damage from region to region.

Due to the complexity of water chemistry, it is important to understand that water quality plays a significant role in the longevity of steam producing equipment. Water quality and required maintenance of steam generating equipment is the direct responsibility of the owner/operator. Damage incurred as a direct result of poor water quality and/or surfaces affected by water quality is also the responsibility of the owner/operator. Damage due to water quality that does not meet the minimum standards shown below is not covered under the Alto-Shaam Combitherm warranty.

It is the sole responsibility of the owner/operator/purchaser of this equipment to verify that the incoming water supply is comprehensively tested and if required, a means of “water treatment” provided that would meet compliance requirements with the published water quality standards published at right. Non-compliance with these minimum standards will potentially damage this equipment and/or components and VOID the original equipment manufacturer’s warranty. Alto-Shaam recommends using OptiPure® [www.optipurewater.com] products to properly treat your water.

Alto-Shaam will continue our efforts to provide viable solutions to ease the impact of water quality as it relates to heat producing equipment.

Alto-Shaam Combitherm Water Quality Standards

Contaminant	Inlet Water Requirements (Untreated Water)
Free Chlorine	Less than 0.1 ppm (mg\L)
Hardness	30-70 ppm
Chloride	Less than 30 ppm (mg\L)
pH	7.0 to 8.5
Silica	Less than 12 ppm (mg\L)
Total Dissolved Solids (tds)	50-125 ppm



Notice: To prevent water pipes from bursting, the incoming water supply should be off when the appliance is not in use.



Notice: Verify that the water supply is open before starting the cleaning program.

WATER SUPPLY AND INSTALLATION

WARNING

Significant damage to the appliance cavity, elements, or heat exchanger could result from improper water quality. Failure to meet the water quality requirements and observe this precaution will void the warranty.

- Flush the water line at the installation site.
- **Backflow Prevention** — The equipment must be installed with a check-valve or other anti-backflow/anti-siphon device on all inlet water lines in accordance with and as required by national, state, and local health, sanitation and plumbing codes.
- **PIPE SEALING TAPE (Teflon®) MUST BE USED AT ALL CONNECTION POINTS.** The use of a pipe sealing compound is not recommended.
- Install a manual water shut-off valve between the main cold water supply line(s) and Combi supply lines.

NOTICE:

To prevent **SERIOUS INJURY** or **PROPERTY DAMAGE**:

Two water supplies are required for proper operation of the oven. Either both water supplies should be treated water or one may be treated and the other untreated. **NEVER** use two untreated water supplies.

Supply lines should be flexible to allow oven to be moved when service or cleaning is needed.

To prevent water supply lines from bursting, incoming water supply should be turned OFF when not in use.

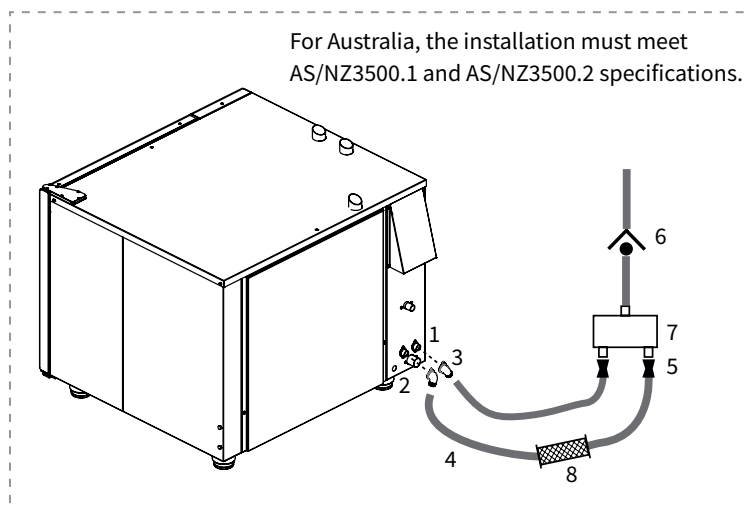
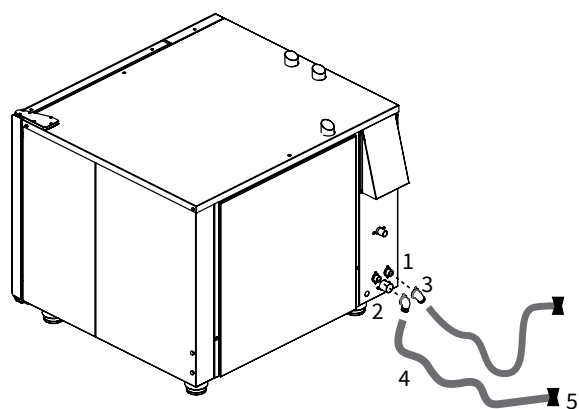

- | | |
|--|---------------------------------|
| 1. Untreated water inlet | 5. Shut-off valve |
| 2. Treated water inlet | 6. Check Valve (inspect yearly) |
| 3. Install a 90° fitting whenever possible on each water line. | 7. Manifold |
| 4. Connect a flexible water line to each inlet fitting. | 8. Filter |

WATER DRAINAGE - FOR SINGLE OVEN

A union is required. Install a 1-1/2-inch (40mm) diameter connection, drain line and clamp into place. The drain line must always be a positive gradient away from the Combitherm oven. An end of drain run air gap may be required by local code. Vertical air vent required.

NOTICE: In the U.S.A., this equipment is to be installed to comply with the Basic Plumbing Code of the Building Officials and Code Administrators International, Inc. [BOCA], and the Food Service Sanitation Manual of the Food & Drug Administration [FDA].

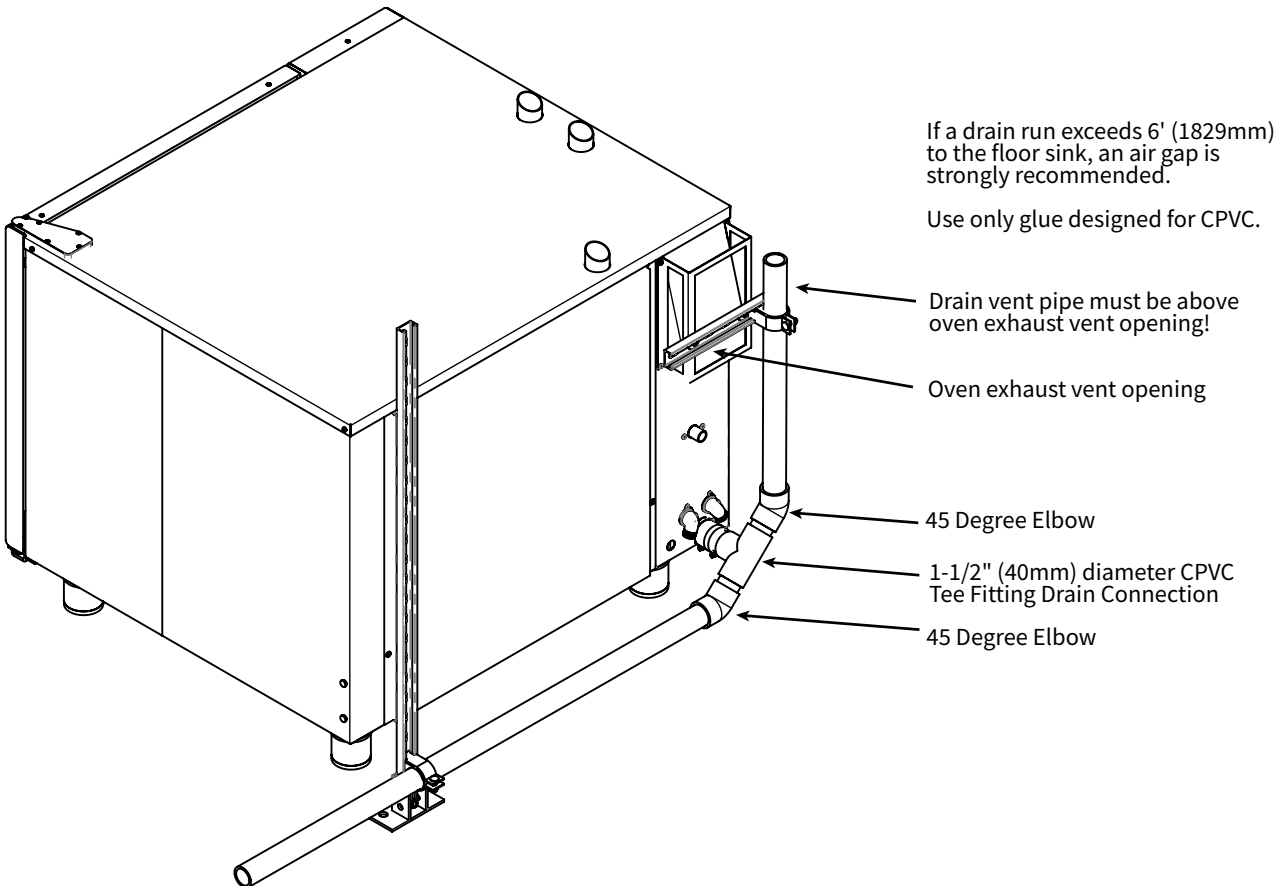

WATER DRAINAGE - FOR STACKED OVEN

A union is required. Install a 1-1/2-inch (41mm) diameter connection, drain line and clamp into place. The drain line must always be a positive gradient away from the Combitherm oven. An end of drain run air gap may be required by local code. Vertical air vent required.

NOTICE: In the U.S.A., this equipment is to be installed to comply with the Basic Plumbing Code of the Building Officials and Code Administrators International, Inc. [BOCA], and the Food Service Sanitation Manual of the Food & Drug Administration [FDA].



WARNING:
To prevent **SERIOUS INJURY** or **PROPERTY DAMAGE** from slippery floor conditions, check drain is connected properly and not blocked.

Local codes may require that the type of material used for the drain pipes be different than the CPVC pipes provided in the installation kit. In such cases, any costs associated with changing the drain pipes to meet the local codes are the responsibility of the end user.

One suggested method of drain installation.

Drain materials must withstand temperatures up to 200°F (93°C).

Installation kits have a maximum run length of 4-1/2' (1372mm).

If a drain run exceeds 6' (1829mm) to the floor sink, an air gap is strongly recommended.

When stacking ovens, run independent drains.

Use only glue designed for CPVC.

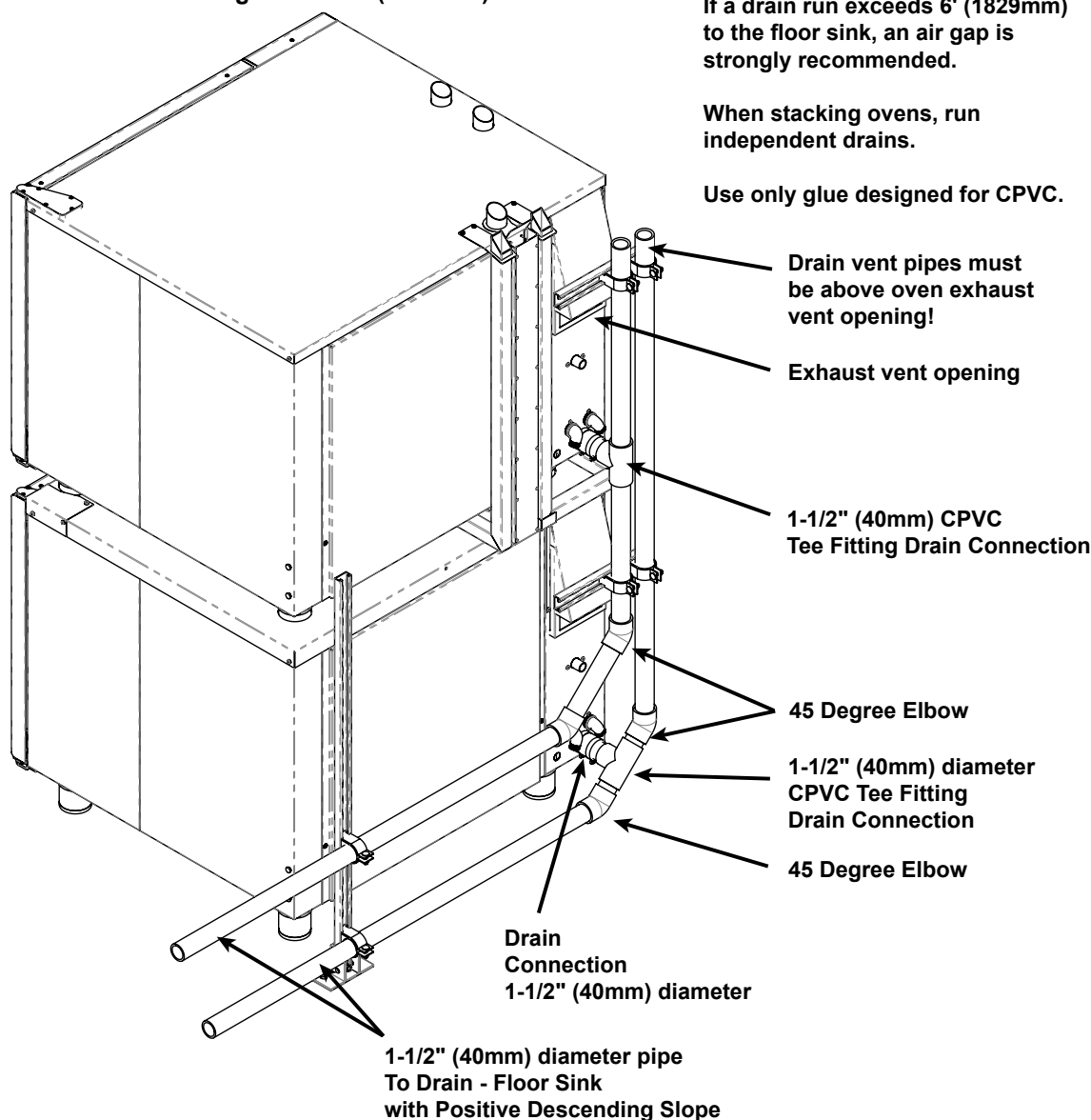

MOBILE EQUIPMENT RESTRAINT**For Gas Models:**

The gas Combitherm must use a connector that complies with The Standard for Connectors for Movable Gas Appliances, ANSI Z21.69 CSA 6.16 and addenda Z21.69a-1989. A quick disconnect device must be installed to comply with The Standard for Quick Disconnect Devices for Use with Gas Fuel, ANSI Z21 CSA 6.9. and European Standard EN203.

Adequate means must be provided to limit the movement of this appliance. Limitation of movement must be made without depending on the connector, the quick disconnect device, nor the associated piping designed to limit appliance movement. If it becomes necessary to disconnect the restraint, it must be reconnected immediately following the return of the appliance to its original position.

1. Install a manual gas shut-off valve along with an approved disconnect device.
2. Install an A.G.A. certified, heavy-duty connector that complies with ANSI Z 21.69 or CAN 1-6.10m88 along with a quick-disconnect device in compliance with ANSI Z21.41 or CAN 1-6.9m70. Connectors must be installed with a cable restraint to prevent excessive tension from being placed on the connector.

FIRE HAZARD

To prevent SERIOUS INJURY or DEATH, your appliance must be secured to building structure to prevent unintended movement.

For Electric Models:

This section is provided for the assistance of qualified and trained service technicians only and is not intended for use by untrained or unauthorized service personnel. Failure to observe this precaution may void the warranty.

WARNING

ELECTRIC SHOCK HAZARD.

To prevent SERIOUS INJURY or DEATH, your appliance must be secured to building structure to prevent unintended movement.

Any appliance that includes a set of casters must be installed with a tether. Adequate means must be provided to limit the movement of this appliance without depending on or transmitting stress to the electrical conduit. The following requirements apply:

1. Casters must be a maximum height of 6" (152mm).
2. Two of the casters must be the locking type.
3. Such mobile appliances or appliances on mobile stands must be installed with the use of a flexible connector secured to the building structure.

A mounting connector for a restraining device is located on the lower back flange of the appliance chassis or on an oven stand, approximately 18" (457mm) from the floor. A flexible connector is not supplied by nor is it available from the factory.

NOTICE: The mobile base used on stacked ovens is not adjustable. The equipment must be placed on a stable, non-combustible level horizontal surface.

COMBIHOOD PLUS™ VENTLESS HOOD OPTION

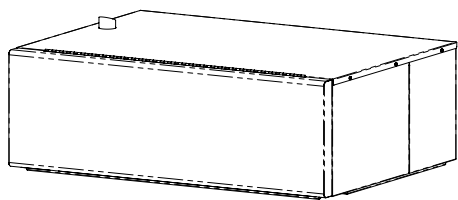

The CombiHood PLUS option is factory installed directly on the top of the Alto-Shaam Combitherm CTP or CTC series oven.

- Using EPA method 202 testing, grease laden vapors emitted by the Combi Ventless hood are 0.58 mg/m^3 – far less than U.L.’s established standard of 5 mg/m^3 .
- A high-powered fan captures all steam and fumes from the oven cavity into the hood intake and out the back surface exhaust vent, trapping grease as the air moves through the filter system.
- As fumes and vapors are circulated through the hood, condensed steam drains from a drain at the rear of the hood.
- An activated charcoal filter cleans the air before venting it out the top of the hood.
- CombiHood PLUS™ performance is “smart”; engaging the fan during the last minute of the cook mode which provides quiet operation and consumes less power.

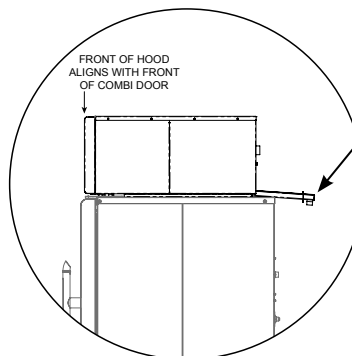

Condensate Drain

A condensate drain line to the floor drain must be installed. The 1/2" barbed connection is found at the back of the hood. The drain line must always be a positive gradient away from the Combitherm oven.

Test the drain for proper drainage and signs of leaking on a monthly basis.

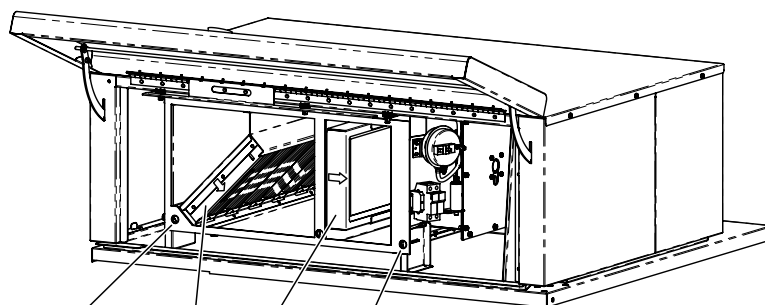

Quarter Turn Release (access to filters)

1

2

Quarter Turn Release (access to filters)

① CombiHood Plus Washable Grease Filter with metal housing (5017362)

Washing frequency should be based on oven usage with a maximum of two weeks between cleaning if the oven is used for non-grease laden products or steam applications only. Grease laden products require cleaning frequency of at least once a week.

Remove the grease filter by pulling it straight out of the housing. Place the filter in the dishwasher or wash separately by placing in hot, soapy water until all grease and particles have been removed. Rinse thoroughly. Allow the filter to air dry before reinstalling.

The air flow arrow on the filter casing should point toward the hood fan when the filter is reinstalled.

② CombiHood Plus Charcoal Filter with paper housing, Class II (FI-25866)

CombiHood Plus Charcoal Filter with metal housing, Class I required for New York City and Los Angeles (FI-36620)

The charcoal filter should be inspected once a month for contaminants. Replacement must be made at a minimum of three month intervals – more often if heavy contaminants are visible or if the filter no longer controls odors.

To remove the filter, pull and slide out while holding the bottom housing. When replacing the filter, make certain the air flow arrow(s) point toward the hood fan, and that the filter is replaced in the three-sided metal frame provided with the hood.

NOTICE: A pressure switch is used to detect when the airflow through the charcoal filter is reduced by 25% - indicating a possible blockage. This will generate an E101 error message on the oven control display. The filters will need to be cleaned or replaced.

If the filters are not seated properly, an error code E102 will appear on the oven control display at the end of a cooking cycle.

GREASE COLLECTION INSTALLATION (IF EQUIPPED WITH THIS OPTION)

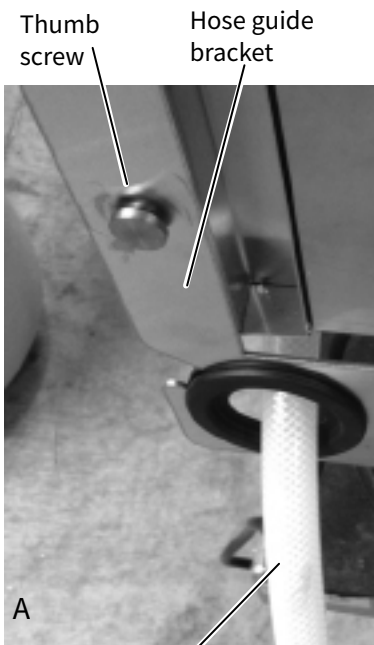

Thumb screw
Hose guide bracket

Grease Collection Hose

Hose hanger bracket with film

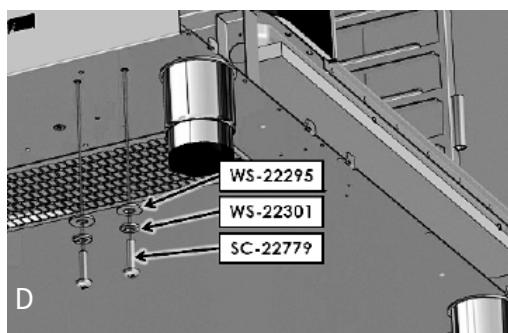

Hose hanger bracket

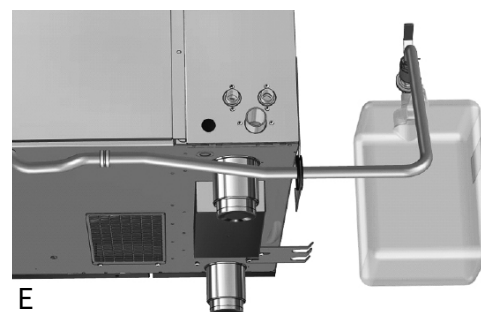
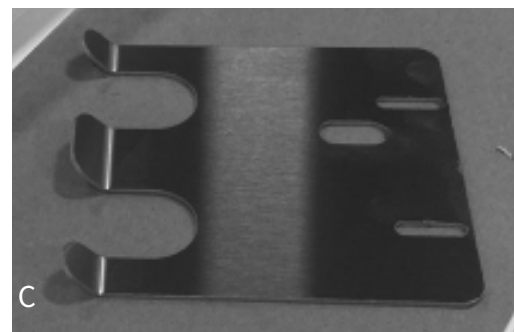

- Grease Collection Hose Assembly is attached to the oven in the back.
- The hose guide bracket can be attached on either the left side or the right side toward the back. **Placement on the left side is recommended whenever possible.** Thumb screws are in position for this purpose. Remove thumb screws, position hose guide bracket and secure screws (PHOTO A). Thread grease hose through the guide.
- The hose hanger bracket can be attached on either the left side or the right side toward the front of the oven. **Placement on the left side is recommended whenever possible.** Remove the plastic protective film from the bracket (PHOTO B,C). Pan head screws are in position beneath the oven for this purpose. **For stacked configurations, always place the hanger bracket on bottom of the top oven.** Remove pan head screws and washers (PHOTO D), position hose hanger bracket on either side of the oven and secure screws and washers (PHOTO E,F). The hanger bracket is used to secure the grease collection hose while changing grease collection containers.
- Place Grease Collection Containers inside the tray of the Mobile Grease Collection Cart. Roll into place next to the oven and **apply the caster brake.**
- ❖ **Loosen vent cap on container.** Pull out the Grease Collection Hose Assembly from the back of the unit. Remove collection container fill cap (PHOTO G).
- Screw Grease Collection Hose Assembly on to collection container until snug.
- Turn ball valve handle to the **ON** position.



Vent Cap
Grease Collection Container
On/Off Ball Valve
Recommended Capacity
Container Fill Cap

LIQUID CLEANER HOOK-UP (IF EQUIPPED WITH THIS OPTION)

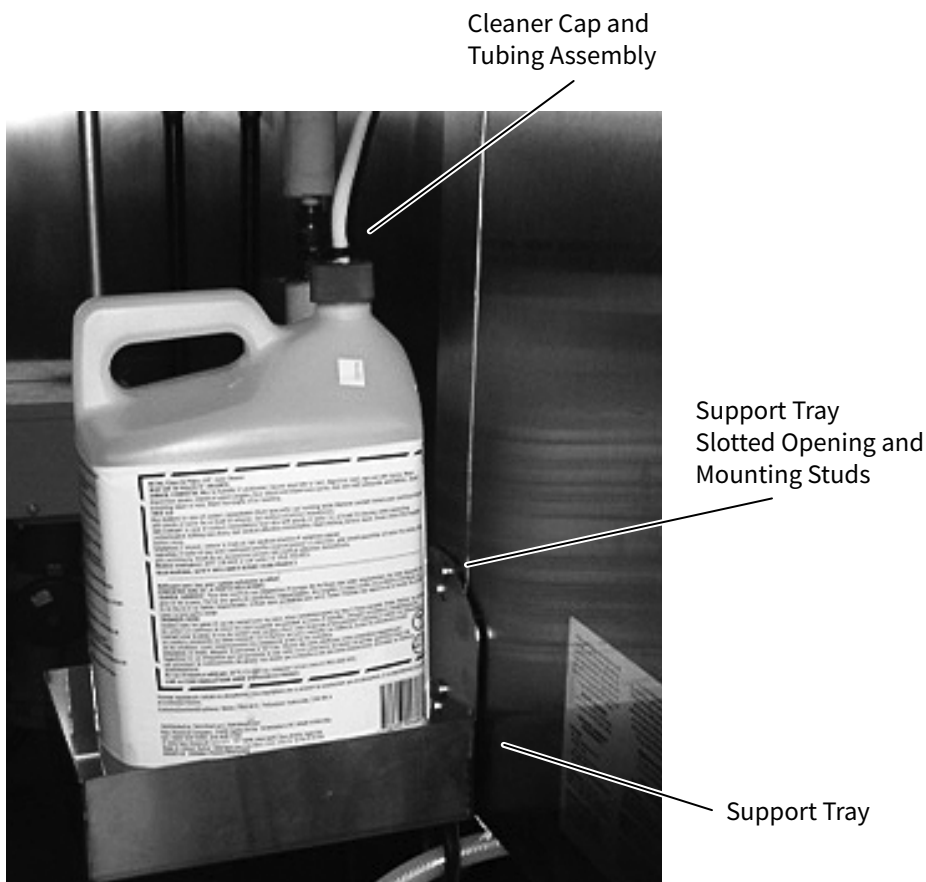

- Removable, cleaner support tray can be mounted on the left or right exterior wall of the oven. Slide slotted openings on the tray over the mounting studs.
- Support tray holds a 2-1/2-gallon (9,5 liter) bottle and measures 10-1/2" x 7-3/4" (267mm x 194mm).
- Place liquid oven cleaner bottle inside tray.
- ❖ Wearing protective rubber gloves and eye wear, remove cap from liquid oven cleaner bottle. Pull out the Cleaner Cap and Tubing Assembly from the back of the unit screw on to liquid oven cleaner bottle.
- ❖ Position cap to ensure the hose is not kinked after tightening.
- Combitherm liquid oven cleaner jugs are quickly and easily replaced.
- Combitherm liquid oven cleaner is automatically pumped through the system, saving labor and providing greater employee safety by eliminating the need to handle caustic cleaning liquids each day.

WARNING	
	<p>ALWAYS wear protective eye wear and rubber gloves when using liquid oven cleaner to prevent eye, skin, and respiratory tract irritation.</p> <p>Keep out of reach of children.</p> <p>See Safety Data Sheet for additional information.</p>

WARNING	
	<p>To prevent SERIOUS INJURY or DEATH, NEVER operate this appliance in a cleaning mode without the liquid cleaner connected, with a kink in the cleaning hose line, or with an empty liquid cleaner container. Failure to do so may result in poor oven cleaning, grease and/or carbon accumulating inside the oven cavity and increased risk of fire.</p>

WARNING	
	<p>To prevent serious personal injury, death, or property damage:</p> <p>The appliance must be cleaned thoroughly to avoid deposits of grease and or food residues inside the appliance that may catch fire. If fat deposits and/or food waste inside the appliance ignite, shut down the appliance immediately and keep the appliance door closed to extinguish the fire. If further extinguishing is required, disconnect the appliance from the main power and use a fire extinguisher (do not use water to extinguish a grease fire!). Failure to clean the appliance properly invalidates the warranty and relieves Alto-Shaam of all liability.</p>

How To Turn On the Appliance

Prerequisites

1. Turn on the exhaust hood.
2. Make sure that the water supply to the appliance is turned on.
3. Make sure that the electrical power supply to the appliance is turned on.
4. For gas appliances, make sure the gas supply valve is in the open position.

Steps

1. Press the ON/OFF button .

The ON/OFF indicator glows green and the loading screen ① displays while the controller software loads. When the software is 100% loaded, the home screen ② displays.



NOTE: If the appliance has a steam generator, the steam generator fills with water and the appliance heats the water to an initial temperature of 188°F (77°C).

How To Start a Manual Calibration

1. Make sure the appliance is off.
2. Press and hold the ON/OFF button  for eight (8) seconds. The ON/OFF indicator glows red and the calibration prompt ③ displays.

The prompt moves from the center to all four corners of the screen. This sequence repeats three (3) times. Then the calibration screen ④ displays.

NOTE: The first time the appliance is turned on, or if the appliance loses power during startup, the touchscreen calibration prompt ③ displays at the end of the next startup.

NOTE: Touch the check mark icon  to start the calibration immediately. Touch the cancel icon  to cancel the calibration.

How To Calibrate the Touchscreen

1. Touch the target icon (+) each time it appears on screen. The icon appears in all four corners, then the center of the screen.

NOTE: If the controller software has not been updated to the current version (11/16 update), the calibration stops when this step is complete. Download the current controller software from the Alto-Shaam website and install it.

2. The verification screen ⑤ displays. Touch all five target icons . The icons change to green boxes when they are touched.

NOTE: The calibration screen and verification screen both display a 30-second countdown. If you do not touch all five icons before the countdown is complete, the controller stops the calibration. If you do not see the countdown, download the current controller software from the Alto-Shaam website and install it.

How To Turn Off the Appliance

1. Press and hold the ON/OFF button  for five to ten (5-10) seconds.

DANGER



Before starting the appliance, make certain you do not detect the odor of gas.

If you smell gas:

- Shut off the gas supply immediately.
- Do not attempt to light any appliance.
- Do not touch any electrical elements.
- Extinguish any open flame.
- Evacuate the area.
- Use a telephone outside the property and immediately contact your gas supplier.
- If unable to contact your gas supplier, contact the fire department.

CAUTION



Accumulations on the main burners of gas appliances can result in firing out of normal sequence. This delayed ignition creates an alarmingly loud sound. If your appliance makes an especially loud noise when starting up, shut down the appliance and call a qualified and trained service technician.

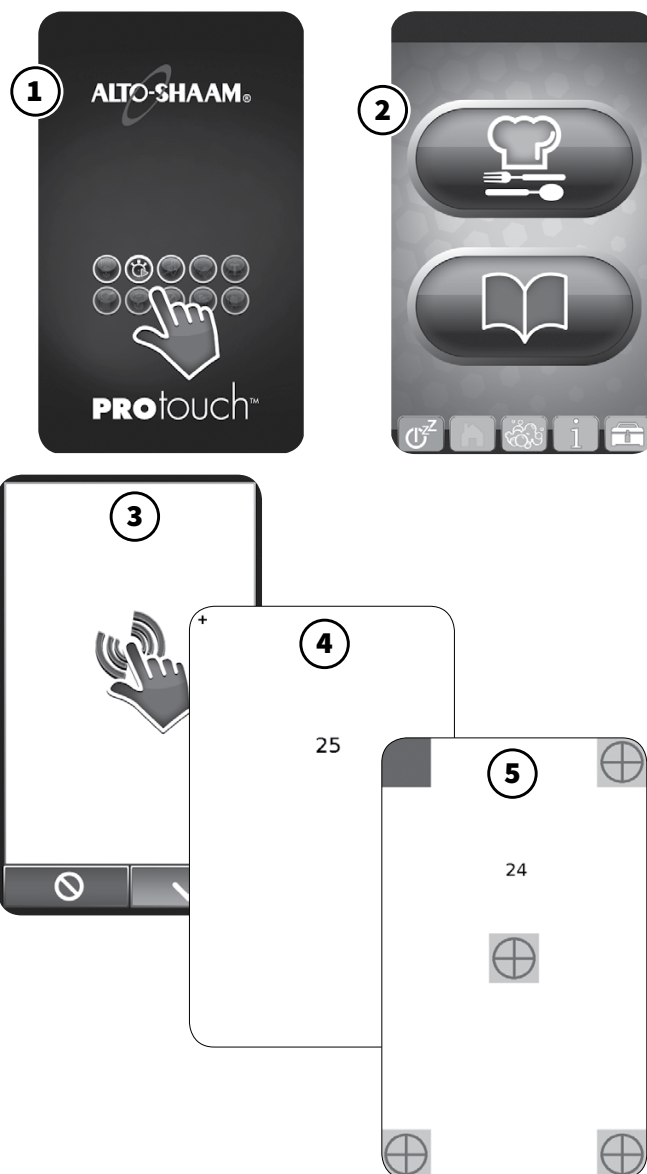

How To Run a Cycle Test of the Appliance

Run the cycle test in combination cook mode

1. Touch the professional cooking mode icon ① in the home screen. The cooking screen displays.
2. Touch the icon for the combination cook mode ②.
3. Touch the displayed temperature ④.
The touchpad displays.
4. If necessary, use the number keys ⑧ to set the cooking temperature to 350°F (177°C), then touch the check mark icon ⑨.
5. Touch the displayed time ⑤. The touchpad screen displays.
6. Use the number keys ⑧ to enter the cooking time (00:15:00), then touch the check mark icon ⑨.
7. Touch the start icon ⑥. The start icon changes to a red square (stop icon) and the appliance begins cooking.
8. Make sure that the appliance cycles correctly.
 1. The appliance raises the cavity temperature to the set temperature.
 2. The appliance cycles off by itself when the set temperature is reached.
 3. The appliance idles until the cavity temperature drops below the set temperature.
 4. The appliance cycles back on by itself until the cavity temperature again reaches the set temperature.

Allow the appliance to run through several cycles.

Cool down the appliance

1. Touch the stop icon ⑥ to stop the cooking process.
2. Touch the cool down icon ⑦. The touchpad screen displays.
3. Use the number keys ⑧ to set the cool down temperature to 110°F (43°C).
4. Open the appliance door.
5. Touch the check mark icon ⑨. The fan activates.
The cool down screen (not shown) displays the cavity temperature at the top and the cool down temperature at the bottom.
The fan turns off when the cavity temperature matches the set cool down temperature.

Run the cycle test in convection cook mode

1. Touch the icon for the convection cook mode ③.
2. Repeat the cycle test steps for convection cook mode.
3. Cool down the appliance when the cycle test is complete.

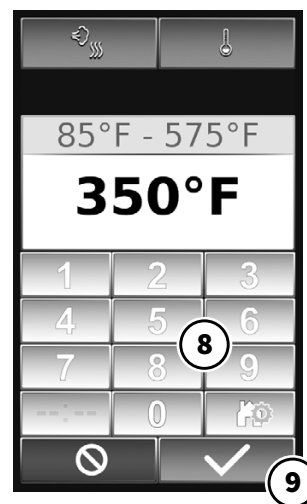

How To Turn On the Appliance

Prerequisites

1. Turn on the exhaust hood.
2. Make sure that the water supply to the appliance is turned on.
3. Make sure that the electrical power supply to the appliance is turned on.
4. For gas appliances, make sure the gas supply valve is in the open position.

Steps

1. Press the ON/OFF button ①. The ON/OFF indicator glows green.

NOTE: If the appliance has a steam generator, the steam generator fills with water and the appliance heats the water to an initial temperature of 188°F (77°C).

NOTE: To power off the appliance, press and hold the Power button for 5 to 10 seconds to initiate the power shut down sequence to the oven.

How To Run a Cycle Test of the Appliance

Run the cycle test in combination cook mode

2. Press the combination cook mode button ②.
3. Press the cook temperature button ③.
4. If necessary, use the up arrow button ⑤ or the down arrow button ⑨ to set the cooking temperature to 350°F (177°C).
5. Press the cook time button ④.
6. Use the up arrow button ⑤ or the down arrow button ⑨ to enter the cooking time (00:15:00).
7. Press the start/stop button ⑩. The appliance begins cooking.
8. Make sure that the appliance cycles correctly.
 1. The appliance raises the cavity temperature to the set temperature.
 2. The appliance cycles off by itself when the set temperature is reached.
 3. The appliance idles until the cavity temperature drops below the set temperature.
 4. The appliance cycles back on by itself until the cavity temperature again reaches the set temperature.

Allow the appliance to run through several cycles.

Cool down the appliance

1. Press the start/stop button ⑩ to stop the cooking process.
2. Press the cool down button ⑦.
3. Use the up arrow button ⑤ or the down arrow button ⑨ to set the cool down temperature to 110°F (43°C).
4. Open the appliance door.

NOTE: The cook time field ⑧ displays “dOOr” if the door is not open.

DANGER



Before starting the appliance, make certain you do not detect the odor of gas.

If you smell gas:

- Shut off the gas supply immediately.
- Do not attempt to light any appliance.
- Do not touch any electrical elements.
- Extinguish any open flame.
- Evacuate the area.
- Use a telephone outside the property and immediately contact your gas supplier.
- If unable to contact your gas supplier, contact the fire department.

CAUTION



Accumulations on the main burners of gas appliances can result in firing out of normal sequence. This delayed ignition creates an alarmingly loud sound. If your appliance makes an especially loud noise when starting up, shut down the appliance and call a qualified and trained service technician.

NOTICE: In the event of a power failure, the oven will not operate.

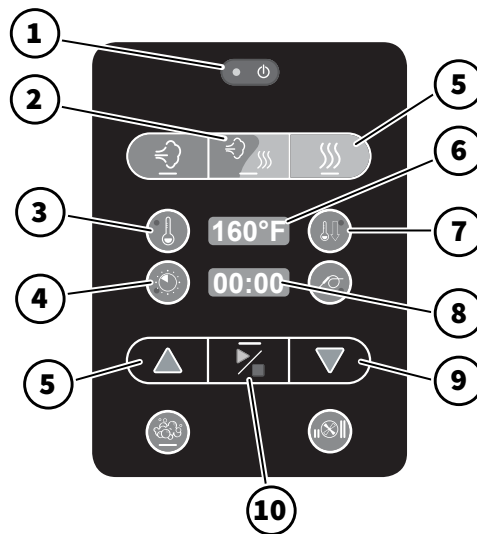

5. Press the start/stop button ⑩. The fan activates. The cook time field ⑧ displays the cavity temperature. The fan turns off when the cavity temperature matches the set cool down temperature.

Run the cycle test in convection cook mode

1. Press the convection cook mode button ⑤.
2. Repeat the cycle test steps for convection cook mode.
3. Cool down the appliance when the cycle test is complete.

Post-Installation Checklist

Location Information	
Location Name: _____	Site Contact Name: _____
Location Street Address: _____	Site Contact Phone No.: _____
Location City: _____	Site Contact Email: _____
Location State: _____ Zip: _____	
Post-Installation Company Information	
Company Name: _____	Technician Name: _____
Mailing Address: _____	Technician Phone No.: _____
City: _____	Contact Email: _____
State: _____ Zip: _____	Date of Installation: _____

Model number(s) of combi's installed				
Serial number of combi's installed				

Clearance					
Appliance clearance	Right side		PASS		FAIL
	Left side		PASS		FAIL
	Rear		PASS		FAIL
	Top		PASS		FAIL
Is the appliance accessible for service?	YES			NO	
If NO, comment on the issue:					
Other comments:					

Water Supply					
Have all Y1/Y3 water lines been connected to water supply (treated/filtered line, if provided)?	PASS		FAIL		
Have all Y2/Y4 water lines been connected to water supply?	PASS		FAIL		
Do water supply line(s) have shut-off(s) exclusively for each appliance?	PASS		FAIL		
Is the dynamic water pressure from the 3/4" cold water supply line a minimum of 30 psi for each appliance?	PASS		FAIL	UNKNOWN	
Is the static water pressure from the 3/4" cold water supply line less than 90 psi for each appliance?	PASS		FAIL	UNKNOWN	
Is water treatment (RO blend system, filter, etc.) being used?	YES		NO	TYPE	
If YES - Note the system here:	BRAND NAME				MODEL
Are all exterior water connections tight?	YES			NO	
Are all interior water connections tight prior to operation?	YES			NO	
Are there any exterior water leaks after operation?	YES			NO	
Are there any interior water leaks after operation?	YES			NO	
Comments:					

Post-Installation Checklist

Electrical									
What is the rated voltage and phase of the appliance(s) installed?	VOLTAGE			PHASE					
Is the wire size for the main incoming power to the appliance(s) in accordance with the minimum size listed in the specification sheet for this specific appliance?	PASS		FAIL						
What is the measured voltage at site?	L1-N		L2-N		L3-N		L1-L2		
	L2-3		L1-L3		PASS		FAIL		
What is the current draw of the appliance(s) to be supplied?	AMP RATING								
What is the on-site breaker size supplying power to the appliance(s)?	SIZE			PASS		FAIL			
Is there a disconnect or junction box within 3' (914mm) of where the appliance(s) will be installed?	PASS		FAIL						
Comments:									
Gas									
Does the gas supply match the information listed on the nameplate of the appliance(s)?	PASS		FAIL						
What is the rated gas supply type?	NAT		PRO						
What is the actual gas supply type?	NAT		PRO						
Is the gas supply piping, water hose lines, electrical support cord and/or receptacle routed away from the path of any hot combustion pipes or fumes?	PASS		FAIL						
Comments:									
Drain									
What type of material was used for the drain?									
Does the vertical drain vent extend above the appliance exhaust opening at the rear of the appliance?	PASS		FAIL						
Is there a vertical vent within 12" (305mm) of the appliance drain?	PASS		FAIL						
Is there an air gap installed at the end of the drain run?	PASS		FAIL	SIZE					
Is the drain piped with a positive descending slope?	PASS		FAIL						
If the appliance has a ventless hood (appliance model name ending in "EVH"), has the ventless hood drain been plumbed along with the appliance main drain.	PASS		FAIL						
Comments:									
Other Site Information									
Is there a proper ventilation hood installed above the location of the appliance(s)?	PASS		FAIL						
Is the appliance level according to leveling instructions in the installation manual?	PASS		FAIL						
Comments:									

Function Test Checklist

Wire Connections				
Behind the left side panel, check and tighten all electrical connections, and tighten all electrical screws.				
Behind the left side panel, check and tighten all electrical screws.				
Behind the control panel, check and tighten all connections on the control board.				
Behind the control panel, check and tighten all connections on the options board.				
Behind the control panel, check and tighten all connections on the interface board.				
Check that the SD card is fully inserted into the interface board.				
Comments:				
Gas Appliances				
With the burner on, check the following:				
Static gas pressure at gas valve must be less than 14" W.C.				
Dynamic gas pressure at gas valve must be greater than 5.5" W.C. for NG; 9" W.C. for propane				
CO ₂ flue gas analysis				
Were burner adjustments required?	YES		NO	
If YES, Record CO ₂ values				
CTP/CTC Appliance Function Test				
Cycle Y1 - Operation fill/Steam injection	YES		NO	
Dynamic water pressure with Y1	MEASURE			
Cycle Y2 - Operation condensate cooling valve	YES		NO	
Dynamic water pressure with Y2	MEASURE			
Cycle Y3 - Operation rinse solenoid valve	YES		NO	
Dynamic water pressure with Y3	MEASURE			
Cycle appliance in steam mode at 212° Fahrenheit (100° Celsius) for 10 minutes. Did the appliance perform correctly?	PASS		FAIL	
Record amperage at all phases:	L1		L2	
	L3			
During the cycle, check CTP motor rotation: 3 minutes clockwise - break - 3 minutes counter-clockwise	PASS		FAIL	
Cycle appliance in convection mode at 350° Fahrenheit (175° Celsius) for 10 minutes. Did it perform correctly?	PASS		FAIL	
Record amperage at all phases:	L1		L2	
	L3			
Cycle appliance in combination mode at 400° Fahrenheit (205° Celsius) for 10 minutes. Did it perform correctly?	PASS		FAIL	
Record amperage at all phases:	L1		L2	
	L3			
Check motor rotation for CTC models. Note: Arrows on the motor housing indicate proper rotation.	PASS		FAIL	
Check all lines and connections for leaks, both inside and outside of the combi appliance.	PASS		FAIL	

Function Test Checklist

Installation Complete				
Cleanup job site				
Wipe down and clean exterior of combi appliance				
Picture of screen displaying current software versions				
Picture(s) of complete drain run				
Picture of water connections at combi appliance				
Picture of gas line and connections at combi appliance				
Picture of appliance in place with surrounding equipment				
Are water supply lines 3/4" inside diameter?	YES		NO	
Size of treated water line:				
Size of untreated water line:				

Has the customer been notified of any issues with the installation?	YES		NO	
Customer Signature				
Technician Signature				

Inspection Checklist



Daily Inspection

Unit Information

Business Name: _____

Serial Number: _____

Model Number: _____

Daily Inspection Start Date: _____

Daily Inspection Checklist

	Monday	Tuesday	Wednesday	Thursday	Friday	Saturday	Sunday
Inspect and clean:							
Product probe (thermometer)							
Door gasket (inner door seal)							
Inner door glass							
Front drip tray							
Screen and overlay (inspect for cracks, peeling, moisture, etc.)							
Execute automatic wash cycle (with approved cleaning chemical ONLY)							
Employee initials							

Component Failure and Replacement

List details of the failure(s) next to the day they occurred. Leave blank if components are working properly.	
Monday	
Tuesday	
Wednesday	
Thursday	
Friday	
Saturday	
Sunday	

Weekly Inspection

Unit Information

Business Name: _____

Serial Number: _____

Model Number: _____

Weekly Inspection Start Date: _____

Weekly Inspection Checklist

Inspect - Oven cavity lamp	
Inspect - Oven cavity for signs of grease/carbon buildup	
Inspect - Loosen thumb screws to inspect behind the fan panel inside the oven cavity for signs of grease/carbon buildup	
Inspect - Loosen thumb screws to inspect behind the fan panel inside the oven cavity for signs of scale buildup	
G Inspect - The heat exchanger for any signs of major deformation. If yes, <i>immediately</i> remove from service and take corrective action steps.	
G Inspect - The heat exchanger for any loose/disconnected pipes or flanges. If yes, <i>immediately</i> remove from service and take corrective action steps.	
E Inspect - Convection elements for signs of cracking, deformation, or damage	
Clean ventless hood grease filters	
Employee initials	

G Gas units only

E Electric units only

Component Failure and Replacement

List details of the failure(s) next to the day they occurred. Leave blank if components are working properly.	
Week 1	
Week 2	
Week 3	
Week 4	

Inspection Checklist

Monthly Inspection

Unit Information

Business Name: _____

Serial Number: _____

Model Number: _____

Monthly Inspection Start Date: _____

Monthly Inspection Checklist

Inspect/Test - Proper draining of the oven cavity	
Inspect - All drain lines for leaks or clogs	
EB Descale the steam generator	
Inspect - Oven cavity for any signs of scale buildup	
Descale the oven interior	
Inspect ventless hood paper filter (replace as needed)	
Test ventless hood drain for proper drainage and signs of leaking	
Employee initials	

EB Electric boiler units only

Component Failure & Replacement

Summarize any component failure(s) that may have occurred during this month.

Yearly Inspection

Unit Information

Business Name: _____

Serial Number: _____

Model Number: _____

12-Month Inspection Start Date: _____

12-Month Inspection Checklist

Replace - Steam bypass hose	
Inspect - Cleaning pump hose	
Inspect/Test - Proper draining of the oven cavity	
Inspect - All drain lines for leaks or clogs	
Inspect - All solenoid hoses (both ends)	
Inspect - Upper browning valve hose	
Inspect - Low pressure relief valve & hose	
E Inspect - Convection element seal (from the electrical compartment)	
G Inspect - Gas heat exchanger seal (from the electrical compartment)	
Inspect - N6 oven temperature probe seal	
EB Descale the steam generator	
EB Remove & Inspect - Steam generator elements	
Inspect - Hand shower hose	
Inspect - Hand shower handle	
Inspect - Product probe	
Inspect - Water injection tube	
Inspect - Oven cavity for any signs of scale buildup	
Inspect - Oven cavity lamp	
Inspect - Oven cavity for signs of grease/carbon buildup	
Inspect - Behind the fan panel inside the oven cavity for signs of grease/carbon buildup	
Inspect - Behind the fan panel inside the oven cavity for signs of scale buildup	

EB Electric boiler units only **G** Gas units only **E** Electric units only

Inspection Checklist

Unit Information

Business Name: _____

Serial Number: _____

Model Number: _____

12-Month Inspection Start Date: _____

12-Month Inspection Checklist

G Inspect - The heat exchanger for any signs of major deformation. If yes, <i>immediately</i> remove from service and take corrective action steps.	
G Inspect - The heat exchanger for any loose/disconnected pipes or flanges. If yes, <i>immediately</i> remove from service and take corrective action steps.	
G Inspect and Ensure - Exhaust pipes are exiting the oven cavity	
G Inspect - Heat exchanger flange gasket (replace as needed)	
G Inspect and Tighten - Heat exchanger flange bolts	
G Inspect and Tighten - Heat exchanger burner flange hardware & gasket (replace as needed)	
G Inspect and Tighten - Heat exchanger igniter flange hardware & gasket (replace as needed)	
G Inspect - Heat exchanger exhaust pipes (ensure they are exiting out past the oven cavity ceiling flange) - ESG models only	
G Inspect - Oven cavity ceiling flange & flange gasket - ESG models only	
G Tighten - Burner flange bolts	
G Tighten - Igniter flange bolts	
Inspect - Heat exchanger weep holes to ensure they are free of obstructions (if the hole is obstructed, immediately remove oven from service and replace the heat exchanger) - Not applicable to CTP/CTC models	
E Inspect - Convection elements for signs of cracking, deformation, or damage	
Replace - Oven lamp cover(s) & gasket(s)	
Descale the oven interior	
Inspect - Door gasket (replace as needed)	
Wipe the inner door glass	
Inspect - Front drip tray (clean as needed)	
Inspect - Front drip tray hose	
Inspect - Control overlay	
Inspect and Tighten - All electrical connections	
Inspect and Tighten - All cooling fans for proper operation	

EB Electric boiler units only **G** Gas units only **E** Electric units only

Unit Information

Business Name: _____

Serial Number: _____

Model Number: _____

12-Month Inspection Start Date: _____

12-Month Inspection Checklist

Inspect and Tighten - Door hinges and lower hinge pin bolt	
Inspect and Tighten - Door handle	
If there is a smoker, inspect the smoke element for visual signs of deformation, cracks or breaks (replace as needed)	
Review - Error code history	
Note the software version (update if not current)	
Record - Water pressure (static & dynamic)	
Record - Line voltage across all lines	
Record - Line voltage to ground on each line	
Record - Amperage across all three legs (when heating)	
Function test all components (list components)	
For ovens shipped to New Zealand or Australia, inspect the backflow preventer check valve per AS/NZ3500.1 and AS/NZ3500.2	

Component Failure and Replacement

Summarize any component failure(s) that may have occurred during this month.

Customer Signature: _____

Technician Signature: _____

Error Codes

ALWAYS check the circuit breaker is turned “ON” and your unit is receiving power BEFORE calling your Authorized Alto-Shaam Service Agent.

NOTICE

This section is provided for the assistance of qualified and trained service technicians only and is not intended for use by untrained or unauthorized service personnel. Do not attempt to repair or service the oven beyond this point. Contact Alto-Shaam for the nearest authorized service agent. Repairs made by any other service agents without prior authorization by Alto-Shaam will void the warranty.

When the oven malfunctions, an error code will appear in the display.



Press the Start icon to acknowledge the error.

When the oven error notification has been acknowledged, the Combitherm will attempt to return to normal operation.

Error Code	Error Call Out in Display	Description of Error	Possible Cause(s)
E01	Low Water Boiler	Upper water level probe B1 is not satisfied within 5 minutes, after water solenoid valve Y1 is activated.	<ul style="list-style-type: none"> – Water supply is shut off. – Low water pressure. – Boiler drain cap is missing. – Boiler drain pump is defective. – Drain pump elbow leaking. – Water level probe has calcium build up. – Double water solenoid valve is defective (Y1). – Relay board, high voltage is defective.
E02	Control Temperature High	Low voltage relay board temperature higher than 176°F (80°C).	<ul style="list-style-type: none"> – Check wiring to all components listed below. – Cooling fan on relay board assembly is defective. – Cooling fan on display board assembly is defective. – Main cooling fan is defective. – Cooling fan on motor drive is defective.
E03	Fan Motor Error	Fan motor does not spin after 60 seconds, detected by the Hall Sensor. Error 03 does not appear if error E53 is detected first.	<ul style="list-style-type: none"> – Check wiring to all components listed below. – If LED on motor control flashes, see error codes for motor control. – Motor or fan wheel locked. – Hall sensor does not detect motor rotation. – Motor Thermo Temperature protection. – Fan wheel damaged.
E04	Lower Fan Motor Error	Lower Fan motor does not spin after 60 seconds, detected by the Hall Sensor. Error 04 does not appear if error E54 is detected first.	<ul style="list-style-type: none"> – Check wiring to all components mentioned below. – If LED on motor control flashes, see error codes for motor control. – Motor or fan wheel locked. – Hall sensor does not detect motor rotation. – Motor Thermo Temperature protection. – Fan wheel damaged.
E05	VFD Comm Failure	When VFD does not respond to a query on the CAN interface.	<ul style="list-style-type: none"> – Loss of power to VFD. – VFD malfunction. – CAN cable disconnected. – CAN address not correct on VFD.

CONTINUED ON NEXT PAGE

Error Codes

Error Code	Error Call Out in Display	Description of Error	Possible Cause(s)
E06	Lower VFD Comm Failure	When VFD does not respond to a query on the CAN interface.	<ul style="list-style-type: none"> – Loss of power to VFD. – VFD malfunction. – CAN cable disconnected. – CAN address not correct on VFD.
E07	Error Received from VFD	When VFD is flashing the green light	– Refer to VFD error code list and match to number of blinks on the green LED of VFD.
E08	Error Received from Lower VFD	When VFD is flashing the green light	– Refer to VFD error code list and match to number of blinks on the green LED of VFD.
E11	Convection Temperature High	<p>In Combination program, cavity temperature N6 is measuring in excess of 572°F (300°C) for a minimum of 25 seconds</p> <p>In Convection program, cavity temperature N6 is measuring in excess of 572°F (300°C) for a minimum of 25 seconds</p>	<ul style="list-style-type: none"> – Check wiring to all components mentioned below. – Steam element contactor locked/on. – N6 oven cavity temperature probe is defective. – N6 oven cavity temperature probe wires connected backwards – Relay board, high voltage, defective.
E13	Boiler Temperature High	Boiler temperature is more than 248°F (120°C) for more than 25 seconds, detected by B4 Probe	<ul style="list-style-type: none"> – Calcium build up in boiler – Check wiring to all components mentioned below. – Steam element contactor locked/on. – B4 boiler temperature probe is defective. – B4 probe wires connected backwards – Water level probe has calcium build up.
E15	Condensor Temperature High	Condensor water temperature is more than 212°F (100°C) for more than 180 seconds, detected by B3 probe	<ul style="list-style-type: none"> – Water supply is shut off. – Check wiring to all components mentioned below. – B3 condensor temperature probe is defective. – B3 condensor probe wires connected backwards – Single water solenoid valve defective (Y2). – Relay board, high voltage, defective.
E20	B11 Core Temperature Probe Single Point Fault	Single point core temperature probe defective or disconnected	<ul style="list-style-type: none"> – Clean probe receptacle pins with sand paper. – B11 Single Point Core Temperature probe with quick connect defective. – B11 Single Point Core Temperature probe wires with quick connect disconnected. – B11 Single Point Core Temperature probe receptacle defective. – B11 Single Point Core Temperature probe receptacle wires disconnected.
E21	N6 Cavity Probe Fault	Cavity temperature probe defective or disconnected	<ul style="list-style-type: none"> – N6 oven cavity temperature probe defective. – N6 oven cavity temperature probe wires.
E22	B10 Core Temperature Probe Multi-point Fault	Multipoint core temperature probe defective or disconnected	<ul style="list-style-type: none"> – B10 multipoint core temperature probe defective. – B10 multipoint core temperature probe wires disconnected.
E23	B4 Boiler Probe Fault	Boiler temperature probe defective or disconnected	<ul style="list-style-type: none"> – B4 boiler temperature probe defective. – B4 probe wires connected backwards.
E24	B5 Bypass Probe Fault	Bypass steam temperature probe defective or disconnected	<ul style="list-style-type: none"> – B5 bypass steam temperature probe defective. – B5 bypass steam temperature probe wires connected backwards.
E25	B3 Condensor Probe Fault	Condensor water temperature probe defective or disconnected.	<ul style="list-style-type: none"> – B3 condensor temperature probe defective. – B3 condensor probe wires connected backwards.
E26	B10 - Point 1 - Core Temperature Probe Multipoint Fault	Multipoint core temperature probe defective or disconnected.	<ul style="list-style-type: none"> – B10 Multipoint Core Temperature probe defective. – B10 Multipoint Core Temperature probe wires disconnected.
E27	B10 - Point 2 - Core Temperature Probe Multipoint Fault	Multipoint core temperature probe defective or disconnected.	<ul style="list-style-type: none"> – B10 Multipoint Core Temperature probe defective. – B10 Multipoint Core Temperature probe wires disconnected.

CONTINUED ON NEXT PAGE

Error Codes

Error Code	Error Call Out in Display	Description of Error	Possible Cause(s)
E28	B10 - Point 3 - Core Temperature Probe Multipoint Fault	Multipoint core temperature probe defective or disconnected.	<ul style="list-style-type: none"> – B10 Multipoint Core Temperature probe defective. – B10 Multipoint Core Temperature probe wires disconnected.
E29	B10 - Point 4 - Core Temperature Probe Multipoint Fault	Multipoint core temperature probe defective or disconnected.	<ul style="list-style-type: none"> – B10 Multipoint Core Temperature probe defective. – B10 Multipoint Core Temperature probe wires disconnected.
E34	Steam Generator Drain Pump Fault	If water level does not drop below lower water level probe after three minutes when steam generator drain pump is activated in cleaning program.	<ul style="list-style-type: none"> – Calcium build up in steam generator drain pump. – Boiler drain pump defective. – Relay board, high voltage, defective. – Water level probe defective.
E36	Steam Temperature High	<p>In Steam program, cavity temperature N6 is measuring in excess of 395°F (200°C) for more than 60 seconds.</p> <p>In Combination program, cavity temperature N6 is measuring in excess of 520°F (270°C), for more than 60 seconds.</p> <p>In Retherm program, cavity temperature N6 is measuring in excess of 395°F (200°C), for more than 60 seconds.</p> <p>In Cleaning program, cavity temperature N6 is measuring in excess of 395°F (200°C), for more than 60 seconds.</p>	<ul style="list-style-type: none"> – Water supply is shut off. – Low water pressure. – Water injection pipe, calcium build up. – Water flow valve defect or calcium build up. – Double water solenoid valve defective (Y1). – Relay board, high voltage, defective.
E40	B3 Fault	B3 probe shorted to ground	<ul style="list-style-type: none"> – Defective or miswired probe.
E41	B4 Fault	B4 probe shorted to ground	<ul style="list-style-type: none"> – Defective or miswired probe.
E42	B5 Fault	B5 probe shorted to ground	<ul style="list-style-type: none"> – Defective or miswired probe.
E43	N6 Fault	N6 probe shorted to ground	<ul style="list-style-type: none"> – Defective or miswired probe.
E44	N8 Fault	N8 probe shorted to ground	<ul style="list-style-type: none"> – Defective or miswired probe.
E45	B10 Fault	B10 probe shorted to ground	<ul style="list-style-type: none"> – Defective or miswired probe.
E46	B10 - Point 1 Fault	B10 probe shorted to ground	<ul style="list-style-type: none"> – Defective or miswired probe.
E47	B10 - Point 2 Fault	B10 probe shorted to ground	<ul style="list-style-type: none"> – Defective or miswired probe.
E48	B10 - Point 3 Fault	B10 probe shorted to ground	<ul style="list-style-type: none"> – Defective or miswired probe.
E49	B10 - Point 4 Fault	B10 probe shorted to ground	<ul style="list-style-type: none"> – Defective or miswired probe.
E51	No Water In Boiler	Lower water level probe B2 is not satisfied within 5 minutes, after water solenoid valve Y1 is activated	<ul style="list-style-type: none"> – Water supply is shut off. – Low water pressure. – Boiler drain cap missing. – Boiler drain pump defective. – Drain pump elbow leaking. – Water level probe has calcium build up. – Double water solenoid valve defective (Y1). – Relay board, high voltage, defective.
E53	Fan Motor High Temperatures	Fan motor does not spin, result in over-heating, detected by motor coil safety thermo element. Temperature more than 320°F (160°C).	<ul style="list-style-type: none"> – Motor high limit open or wired incorrectly. – If LED on motor control flashes, see error codes for motor control. – Motor or fan wheel locked. – Fan wheel damaged.
E54	Lower Fan Motor High Temperature	Lower fan motor does not spin, result in over-heating, detected by motor coil safety thermo element. Temperature more than 320°F (160°C).	<ul style="list-style-type: none"> – Motor high limit open or wired incorrectly. – If LED on motor control flashes, see error codes for motor control. – Motor or fan wheel locked. – Fan wheel damaged.

CONTINUED ON NEXT PAGE

Error Codes

Error Code	Error Call Out in Display	Description of Error	Possible Cause(s)
E55	Vent Not Open (Lower vent on dual vent system)	60 seconds after the venting motor is activated the vent motor safety switch did not open.	<ul style="list-style-type: none"> – Alignment issue between motor cam and vent motor safety switch (micro switch). – Faulty vent valve (motor). – Faulty vent valve safety switch (micro switch).
E56	Vent 2 Not Open (Upper vent on dual vent system)	60 seconds after the venting motor is activated the vent motor safety switch did not open.	<ul style="list-style-type: none"> – Alignment issue between motor cam and vent motor safety switch (micro switch). – Faulty vent valve (motor). – Faulty vent valve safety switch (micro switch).
E57	No Rinse Water	Flow switch for solenoid valve Y4 does not detect any water flow for a minimum of 60 seconds.	<ul style="list-style-type: none"> – Water supply is shut off. – Low water pressure. – Flow switch is dirty or defective. – Double water solenoid valve defective (Y3). – Relay board, high voltage, defective.
E88	Lower Gas Ignition Failure NOTE: If after 2 attempts to clear this error, the error appears a third time, remove the oven from service and immediately contact an Alto-Shaam authorized service provider.	Reset output from Ignition Module is ON	<ul style="list-style-type: none"> – Hot surface ignitor not functioning. – No gas supply. – Flame sensor not functioning. – Faulty ignition control.
E89	Upper Gas Ignition Failure NOTE: If after 2 attempts to clear this error, the error appears a third time, remove the oven from service and immediately contact an Alto-Shaam authorized service provider.	Reset output from Ignition Module is ON	<ul style="list-style-type: none"> – Hot surface ignitor not functioning. – No gas supply. – Flame sensor not functioning. – Faulty ignition control.
E90	Lower Gas Combustion Blower Not at Speed	Speed is too slow.	<ul style="list-style-type: none"> – Power supply cable is not connected to blower motor. – Speed control cable is not connected to blower motor. – Blower motor is blocked, rotation is impeded, or motor is faulty. – Faulty control board.
E91	Upper Gas Blower Not at Speed	Speed is too slow.	<ul style="list-style-type: none"> – Power supply cable is not connected to blower motor – Speed control cable is not connected to blower motor – Blower motor is blocked, rotation is impeded, or motor is faulty – Faulty control board
E92	Communication Error CB does not properly respond	Twelve (12) instances of no-response from the relay board (CB) to the display board (IB).	<ul style="list-style-type: none"> – Check CAN cable connections. – CAN cable defective. – Relay board, low voltage, connector defective. – Display board connector defective.
E93	Interface Board (IB) and Control Board (CB) are in different states	The IB is in a different running state than the CB for more than 20 seconds.	<ul style="list-style-type: none"> – Check CAN cable connections. – CAN cable defective. – Relay board, low voltage, connector defective. – Display board connector defective.
E94	Communication Error, TO Interface Board	No signal transfer for more than 20 seconds between the Interface Board (IB) and the Control Board (CB).	<ul style="list-style-type: none"> – Check CAN cable connections. – CAN cable defective. – Relay board, low voltage, connector defective. – Display board connector defective.

CONTINUED ON NEXT PAGE

Error Codes

Error Code	Error Call Out in Display	Description of Error	Possible Cause(s)
E100	One or more maintenance reminder has timed out.	When any maintenance reminder has expired without action having been taken by the operator.	<ul style="list-style-type: none"> – Enter maintenance reminder screen and address the item that has timed out and reset
E101	Ventless Hood Fault - No Pressure	If the power switch or pressure switch is not closed.	<ul style="list-style-type: none"> – Check power switch is on. – Check vent motor is turning in the proper direction. – Pressure switch is miss wired or defective. – Filter(s) require cleaning or replacement
E102	Ventless Hood Fault – Filters Not Present	If the air filter switches are not closed.	<ul style="list-style-type: none"> – Check filters are installed and properly seated. – Check filter switches are not damaged, defective or dislodged.
E103	Option Board Doesn't Send Switch Setting	OB not communicating its switch settings to the CB.	<ul style="list-style-type: none"> – Check CAN cable connection between OB and CB. – Ensure CB dip switch is set to see an OB. – Incompatible OB and CB software (update software). – OB defective. – CB defective.
E104	Option Board Not Communicating	Option board is not communicating with CB.	<ul style="list-style-type: none"> – Check option board CAN connection at CB and OB. – Defective OB. – Defective CB.
E105	No or Low Water Pressure	Water pressure switch not activated.	<ul style="list-style-type: none"> – Water supply not connected. – Water supply is shut off. – Water supply to unit blocked or obstructed – Faulty or miswired pressure switch
E106	Boiler Drain Pump Fault	Hall effect or rotational sensor is not sending a signal to the relay board	<ul style="list-style-type: none"> – Drain pump motor not running or defective. – Hall effect sensor broken or incorrectly wired. – Motor improperly wired.
E108	Cooling Fan Failure	If the temperature on the control board (relay board) is greater than 140°F (60°C) and less than 176°F (80°C). (See error code E02)	<ul style="list-style-type: none"> – Cooling fan damaged. – Cooling fan blocked or blades have been kept from rotating. – Incoming air temperature exceeds 100°F (38°C). – Air inlet has become blocked.
E109	High Limit Switch NOTE: Any oven experiencing this error should be investigated by an authorized Alto-Shaam service provider.	The High Limit Switch input to the CB (N7) is “open”	<ul style="list-style-type: none"> – Unit has experienced an over heat condition. – Convection element contactors stuck closed. – Failed Y1 solenoid. – Obstruction between Y1 solenoid and injection pipe. – Improperly connected drain. – Condensate pan clean out not closed. – Improperly wired high limit switch at the switch or at the CB. – Defective high limit switch.

CONTINUED ON NEXT PAGE

Error Codes

Error Code	Error Call Out in Display	Description of Error	Possible Cause(s)
E200	The SD card has been detected to be larger than 2GB in size.	The SD card inserted is larger than 2GB in size.	– SD card is larger than 2GB in size. Contact service to order replacement SD card.
E210	VFD Under Voltage	VFD has detected an under-voltage situation.	– Possible VFD failure.
E211	VFD Over Voltage	VFD has detected an over-voltage situation.	– Possible VFD failure.
E212	VFD Overheating	VFD has detected an overheat situation.	– Unit has experienced an over heat condition. – Defective high limit switch. – Defective cooling fans. – Possible VFD failure.
E213	Motor Over Current	Motor over current detected.	– Blocked fan wheel. – Possible VFD failure.
E214	VFD Current Peak	VFD current peak detected.	– Possible VFD failure.
E215	VFD EEPROM Error	VFD EEPROM error detected.	– Possible VFD failure.
E216	VFD Over Current	VFD over current detected.	– Possible VFD failure.
E217	VFD Short Circuit	VFD Short Circuit detected.	– Possible VFD failure.
E218	VFD Voltage Error	VFD voltage does not correspond to jumper settings.	– VFD voltage jumper is not correct. – Possible VFD failure.
E220	Lower VFD Under Voltage	Lower VFD has detected an under-voltage situation.	– Possible Lower VFD failure.
E221	Lower VFD Over Voltage	Lower VFD has detected an over-voltage situation.	– Possible Lower VFD failure.
E222	Lower VFD Overheating	Lower VFD has detected an overheat situation.	– Unit has experienced an over heat condition. – Defective high limit switch. – Defective cooling fans. – Possible Lower VFD failure.
E223	Lower Motor Over Current	Lower Motor over current detected.	– Possible Lower VFD failure.
E224	Lower VFD Current Peak	Lower VFD current peak detected.	– Possible Lower VFD failure.
E225	Lower VFD EEPROM Error	Lower VFD EEPROM Error detected.	– Possible Lower VFD failure.
E226	Lower VFD Over Current	Lower VFD over current detected.	– Possible Lower VFD failure.
E227	Lower VFD Short Circuit	Lower VFD short circuit detected.	– Possible Lower VFD failure.
E228	Lower VFD Voltage Error	Lower VFD voltage does not correspond to jumper settings.	– Lower VFD voltage jumper is not correct. – Possible Lower VFD failure.
E289	Unknown Error from VFD	VFD has provided an unknown error.	– Possible VFD failure.
E290	Unknown Error from Lower VFD	Lower VFD has provided an unknown error.	– Possible Lower VFD failure.

Touch Motor Control Error Codes

The LED is located on the variable frequency drive (VFD) ① of the oven.

Type of Error	Indication	Release of Error
Undervoltage	LED flashing sequence, with 1 flash per period.	Voltage of intermediate circuit is less than 250V
Overvoltage	LED flashing sequence, with 2 flashes per period.	Voltage of intermediate circuit exceeds 445V
Excess Temperature	LED flashing sequence, with 3 flashes per period.	Temperature sensor in the power unit is more than 199°F (93°C)
Current Peak	LED flashing sequence, with 4 flashes per period.	Blocked motor, detected by current peak monitoring from 900 rpm rotating field
Overcurrent	LED flashing sequence, with 5 flashes per period.	Intermediate circuit current exceeds 4.0 A
Short-circuit	LED flashing sequence, with 6 flashes per period.	Release of interrupt at intermediate circuit current larger than 53 A
Power on	LED flashing sequence, with 7 flashes per period.	Effective mains voltage does not correspond to jumper setting 115V/230V
Watchdog	LED flashing sequence, with 8 flashes per period.	Watchdog of the microcontroller released, program crash

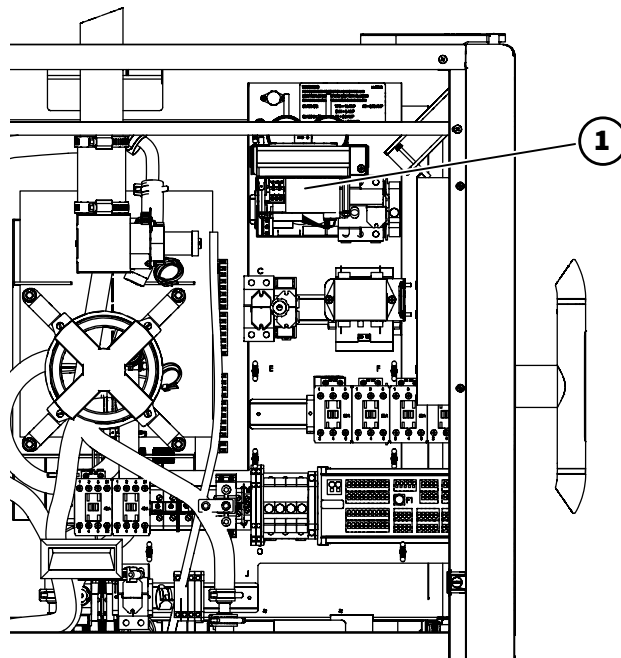

Alto-Shaam, Inc. warrants to the original purchaser that any original part that is found to be defective in material or workmanship will, at Alto-Shaam's option, subject to provisions hereinafter stated, be replaced with a new or rebuilt part.

The labor warranty remains in effect one (1) year from installation or fifteen (15) months from the shipping date, whichever occurs first. Alto-Shaam will bear normal labor charges performed by an authorized Alto-Shaam service agent during standard business hours, excluding overtime, holiday rates or any additional fees.

The parts warranty remains in effect for one (1) year from installation or fifteen (15) months from the shipping date, whichever occurs first. An optional extended warranty is available but must be purchased with the original equipment order. Please consult the factory for net pricing options and details.

This warranty does not apply to:

1. Replacement of wear parts, including light bulbs, door gaskets, and/or the replacement of glass due to damage of any kind.
2. Equipment damage caused by accident, shipping and handling, improper installation or alteration of any kind.
3. Equipment chassis or component/system damage as a result of inadequate routine maintenance and cleaning. Required maintenance and cleaning of steam generating equipment is the responsibility of the owner/operator.
4. Equipment used under conditions of abuse, neglect, misuse, carelessness or abnormal conditions including, but not limited to, equipment subjected to non-approved or inappropriate chemicals including, but not limited to, compounds containing chlorine, chlorides or quaternary salts, or equipment with missing or altered serial numbers. Damage caused by use of any cleaning agent other than Alto-Shaam's Combitherm® Oven Cleaner including, but not limited to, damage due to chlorine, bleach, quaternary salts, souring powders or other harmful chemicals. Use of Alto-Shaam's Combitherm® Cleaner on Combitherm appliances is highly recommended.
5. It is the sole responsibility of the owner/operator/purchaser of this equipment to verify that the incoming water supply is comprehensively tested and if required, a means of "water treatment" provided that would meet compliance requirements with the published water quality standards published at right. Non-compliance with these minimum standards will potentially damage this equipment and/or components and VOID the original equipment manufacturer's warranty. Alto-Shaam recommends using OptiPure® products to properly treat your water.
6. Any losses or damage resulting from malfunction, including loss of product or consequential or incidental damages of any kind.
7. Equipment damage resulting from modification in any manner from original model, substitution of parts other than factory authorized parts, removal of any parts including legs, or addition of any parts.

COMBITHERM WATER QUALITY MINIMUM STANDARDS

CONTAMINANT	INLET WATER REQUIREMENTS
Free Chlorine	Less than 0.1 ppm (mg/L)
Hardness	30-70 ppm
Chloride	Less than 30 ppm (mg/L)
pH	7.0 to 8.5
Silica	Less than 12 ppm (mg/L)
Total Dissolved Solids (tds)	50-125 ppm

This warranty is exclusive and is in lieu of all other warranties, expressed or implied, including the implied warranties of merchantability and fitness for a particular purpose. In no event shall Alto-Shaam be liable for loss of use, loss of revenue or profit, or loss of product, or for any indirect, incidental or consequential damages.

No person except an officer of Alto-Shaam, Inc. is authorized to modify this warranty or to incur on behalf of Alto-Shaam any other obligation or liability in connection with Alto-Shaam equipment.

Warranty effective January 1, 2014

CT Classic™
 CT PROformance™
COMBITHERM®



Alto-Shaam World Headquarters

W164 N9221 Water Street, PO Box 450
 Menomonee Falls, WI 53052-0450, U.S.A.
 Phone 800-558-8744; +1-262-251-3800

Alto-Shaam Asia

Shanghai, China
 Phone +86-21-6173 0336

Alto-Shaam Canada

Concord, Ontario Canada
 Toll Free Phone 866-577-4484
 Phone +1-905-660-6781

Alto-Shaam Central & South America

Miami, FL USA
 Phone +1-954-655-5727

Alto-Shaam Middle East & Africa

Dubai, UAE
 Phone +971 4 321 9712

Alto-Shaam France, L.L.C.

Aix en Provence, France
 Phone +33(0)4-88-78-21-73

Alto-Shaam GmbH

Bochum, Germany
 Phone +49(0)234-298798-0

Alto-Shaam Mexico

Leon, Mexico
 Phone +52 1 477-754-1305

Alto-Shaam Russia

Moscow, Russia
 Phone +7-903-793-2331