

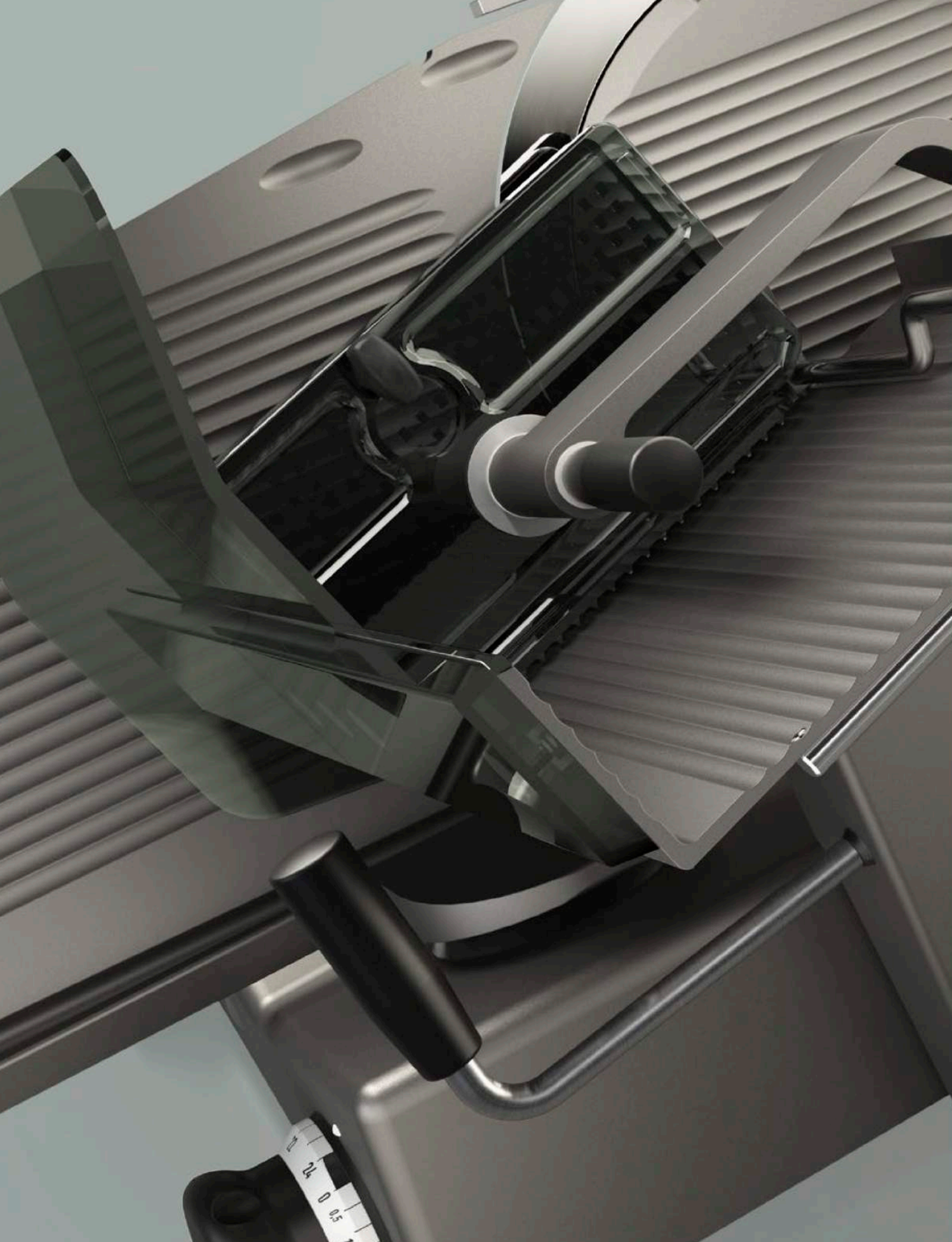

GSP gravity feed slicers

Pure diversity

BIZERBA



BIZERBA

OPEN
WORLD



Our experience sets standards

We are a family-owned company guided by a commitment to tradition, sustainability and responsibility. Nowadays, based on our core competence of slicing and weighing technology, we offer our customers the industry's largest and most unique range of products and solutions as hardware, software and services, anywhere in the world.

As a globally operating technology company we are guided by our goal and commitment to achieve maxi-

mum results in terms of ergonomic design, hygiene, safety and efficiency. We believe we have a role to play in shaping our markets, and are continually setting new industry standards. In close collaboration with our customers and against a backdrop of technological advancement, we are working to improve our products on a daily basis—resulting in innovations which become new standards.

In order to continue to live up to these requirements, we focus on the highest possible quality standards

and internationally recognized technology standards in our development and manufacturing work. This is how we best support our customers in achieving maximum efficiency and profitable growth.

Our experience sets standards.

That's what sets us apart. Bizerba.

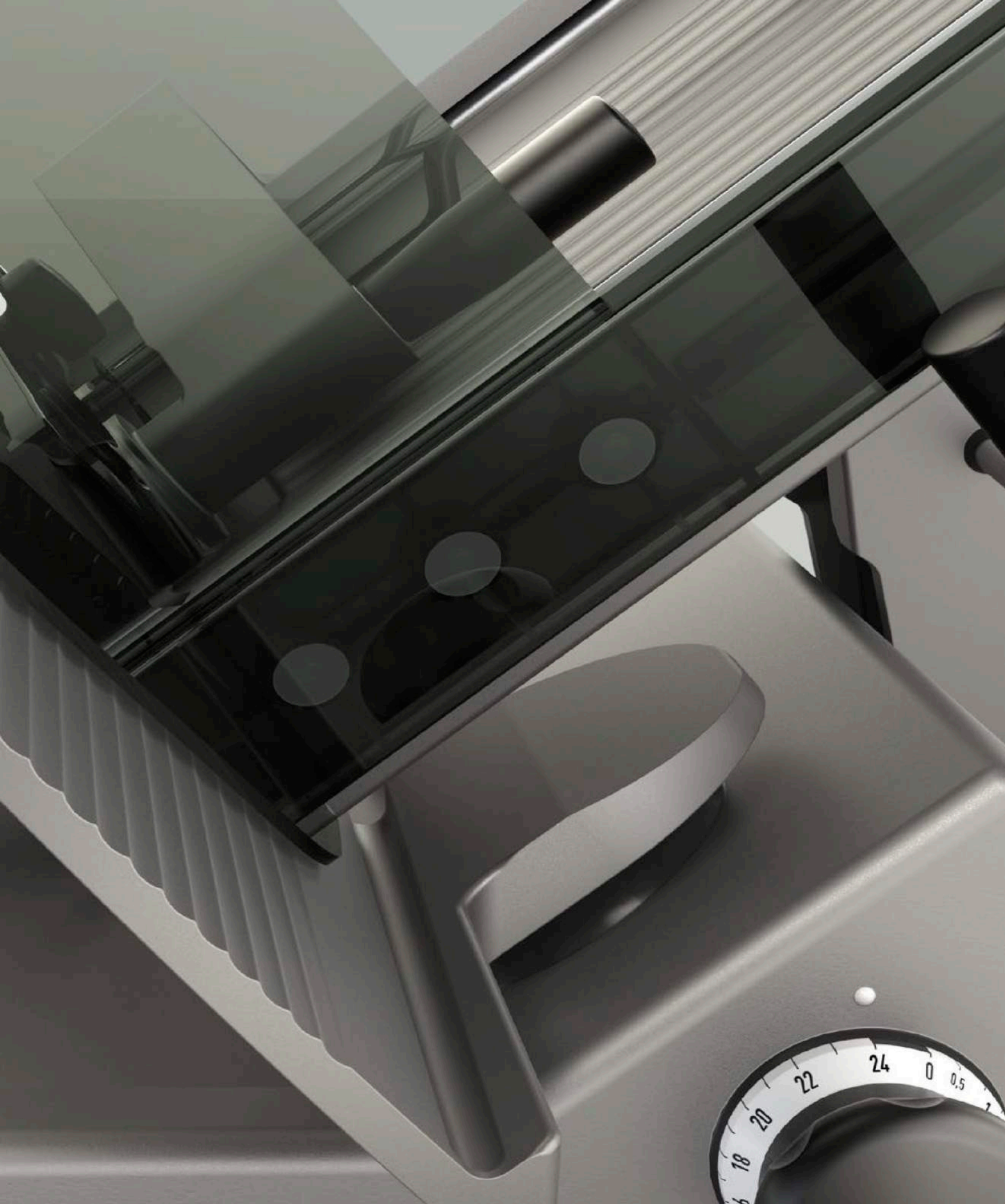

Made-to-measure quality

The GSP series represents premium quality that can be perfectly aligned with your individual needs. Its ergonomic design utilizes the laws of gravity and defines global standards for hygiene, safety and energy efficiency.

When conceptualizing the GSP models we paid close attention to the practical situation in your industry. The result: Modular gravity feed slicers that can be configured in line with your own individual requirements. This building-block principle gives you precisely the flexibility you need when selecting the type of product to be sliced, the slice thickness and/or height of the stack. Thanks to the wide range of configuration options and various accessories, you always achieve precise and efficient slicing results.

In the case of the GSP series, premium also means: All models, whether manual or automatic, have a high-quality and durable finish and are designed for optimum comfort during use. They comply with the highest safety and hygiene standards. The same holds true for our integrated slicing and weighing solution. Safeguard access to more opportunities that meet your needs, both now and in the future, in every phase of value creation—including in terms of ergonomics and energy efficiency.

Designed for performance

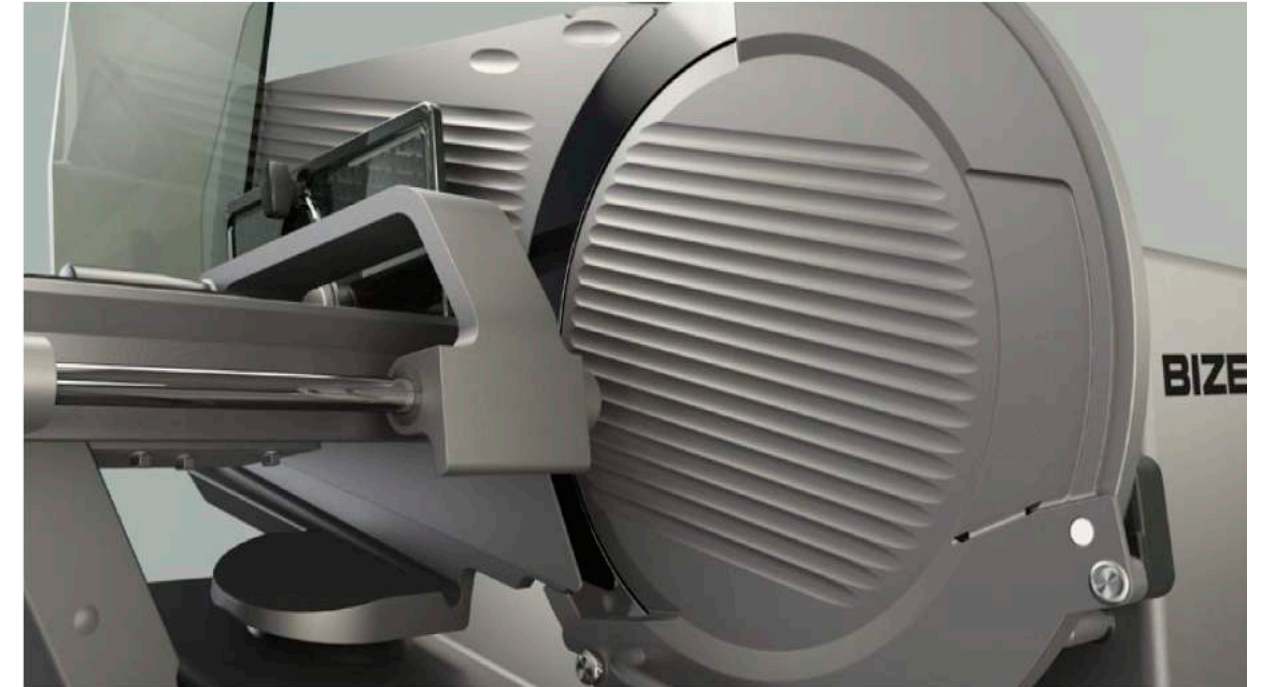

Hygiene

The hygienic design of the GSP series guarantees high-quality products and efficient cleaning. The large distance between the motor tower and blade facilitates easy cleaning. The aluminum-eloxal surface of the slicer is closed, smooth and has rounded edges. There is nowhere for dirt to collect. Juices from the sliced products run off via the drain integrated in the gauge plate. The blade cover prevents any splashes from the remaining product. Surfaces refined with Ceraclean® impress thanks to their optimal non-stick and gliding properties: Liquids simply run off, and greasy and very sticky remnants can be removed quickly. The surfaces are easy to clean and dishwasher safe. The same is true of the removable sharpener.

Safety

In the GSP series, operator protection is the top priority. The series complies with international safety standards. Our safety package avoids risks at every stage of the slicing process: The stable blade guard and blade cover minimize the chance of injury during operation. The illuminated slice thickness button provides at-a-glance and visually clear information about the device mode (Green: closed slice thickness, the blade is motionless. Red: open slice thickness, the blade is in operation). The start/stop function integrated in the slice thickness button or the switch-off function automatically turn off the device after a preset length of time. The sharpener also optimally protects the employee from accidentally reaching into it thanks to the precisely defined sharpening and withdrawal arrangement.

Ergonomic design

The GSP series have been ergonomically designed to allow you to concentrate fully on your work and your customers. The high-performance technology, the modular machine concept and the materials used have all been selected to provide the best operational comfort. You benefit from efficient processes and an increased productivity: Slicing is intuitive, safe and effortless. Even heavier products can be sliced manually with the utmost ease. The inclination ensures that they slide down automatically. The product's own weight holds it in place securely and ensures clean, precise slicing. Cleaning can be completed rapidly thanks to the tool-less disassembly of the components, the elegant lifting device, and the patented quick-close system.

Energy efficiency

In the GSP series we have integrated a high-performance and energy-efficient motor concept. The cutting performance is outstanding. It is even possible to achieve a clean cut in dry-cured ham. To save energy and costs, the devices automatically switch off if they have been inactive for a while. The intelligent drive technology Emotion® enables you to save energy costs with every slice: the motor adapts its performance to the individual resistance of the product to be cut. Meanwhile, you benefit from improved product quality: only a tiny amount of heat is generated around the blade and in the depositing area so that your products stay fresh for longer. An additional positive effect for your employees and customers alike is the fact that the motor is extremely quiet, contributing to a pleasant in-store atmosphere.

Integrated solution

The GSP series represents real added value. With the GSP H Flex, we have developed an integrated solution which brings together the tasks of slicing and weighing in perfect harmony. We have optimally combined the performance of the GSP H manual slicer and the K-Class Flex II retail scale. The result: A multifunctional retail solution which complies with international standards and offers you top-class ergonomics during operation and cleaning alike. Your advantages: Service-counter employees work efficiently and multifunctionally with everything close to hand, facilitating active customer contact. From advising, slicing, weighing, packing and payment transactions to information on the customer display.

Modularity

The modular machine concept of the GSP series offers you a broad diversity of variations. You gain access to more opportunities: Meats, sausages, cheeses and vegetables with a wide variety of textures and consistencies can all be sliced with the utmost precision, from wafer-thin sausage slices to thick slices of meat. With a flexible choice of settings, carriages, blades, fixation devices and special accessories, you can find the optimum solution for every type of product. The variably configurable carriage inclination and selectable height of the carriage foot (high/low) give you complete freedom in terms of product size and stack height. Large products can be handled easily, precisely, and safely thanks to the pivoted remnant holder. The operator determines the optimal carriage speed and stroke length at all times.



GSP HD

Highlights

- Hygienic design:
 - Dishwasher-safe Ceraclean® attachment parts
 - Large distance between blade and motor tower for easy cleaning by hand
 - Guided run-off of meat and product juices
 - Smooth, rounded surface without seams
 - Removable, dishwasher-safe sharpener
- 40° angled blade and flexible carriage inclination (18°/25°)
- Innovative blade cover: Intelligent quick-close system for easy assembly and disassembly
- Integrated comfort package: Servo-supported manual slicing
- Emotion®:
 - Intelligent drive technology
 - Reduced energy consumption
 - Zero energy consumption when switched off
 - Only minimal heat generated in the device and hence in the product to be cut
 - Very low noise level
- Numerous carriage versions available

*Options

- Exclusive Ceraclean® surface finish
 - Excellent gliding properties
 - Easy product guidance
 - Rapid cleaning
 - Dishwasher safe
- Individual equipment:
 - Blade: Ceraclean® blade, cheese blade, bread blade
 - Numerous carriage versions
 - Blade changing device
 - Blade cover
 - Product fixation device
 - Placement (rubber feet, lifting device)
- Portion scale
- Safety package:
 - Illumination: Visual display showing the current device mode
 - Automatic switch-off function after a preset time interval
 - Automatic start/stop function via the slice thickness button
 - Stable blade guard and cover

Dimensions

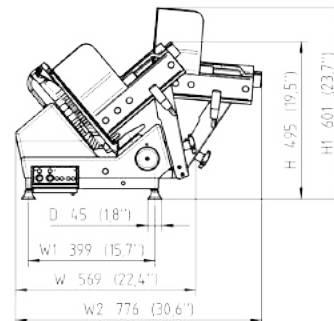
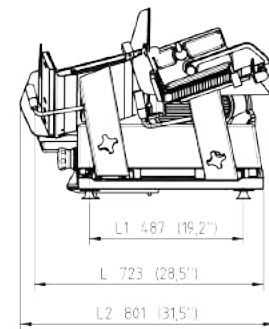

GSP HD

BIZERBA



GSP H

Highlights

- Hygienic design:
 - Dishwasher-safe Ceraclean® attachment parts
 - Large distance between blade and motor tower for easy cleaning by hand
 - Guided run-off of meat and product juices
 - Smooth, rounded surface without seams
 - Removable, dishwasher-safe sharpener
- 40° angled blade and flexible carriage inclination (0°/18°/25°)
- Innovative blade cover: Intelligent quick-close system for easy assembly and disassembly
- Powerful Bizerba motor
- Numerous carriage versions available

*Options

- Exclusive Ceraclean® surface finish
 - Excellent gliding properties
 - Easy product guidance
 - Rapid cleaning
 - Dishwasher safe
- Individual equipment:
 - Blade: Ceraclean® blade, cheese blade, bread blade
 - Numerous carriage versions
 - Blade changing device
 - Blade cover
 - Product fixation device
 - Placement (rubber feet, lifting device)
- Portion scale
- Safety package:
 - Illumination: Visual display showing the current device mode
 - Automatic start/stop function via the slice thickness button

Dimensions

0° carriage inclination

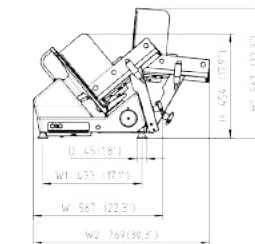
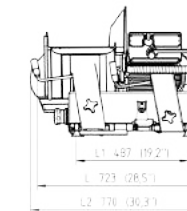

18° carriage inclination

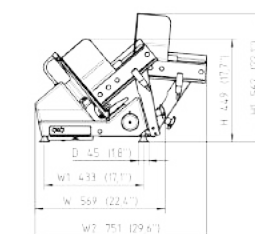
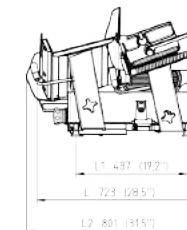

GSP H

BIZERBA



GSP H Flex

Highlights

- Metrologically approved combination of integrated K-Class Flex II PC scale and GSP H gravity feed slicer
- Multifunctional use: Slicing, Weighing, Transaction handling, Inventory, Data management, Advising, Informing, Marketing/Cross Selling
- Flexible arrangement of components thanks to modular system
- Easy to integrate into sales counters
- VESA-standard mounting system
- Efficient cleaning of all components
- Easy to replace paper rolls
- 40° angled blade and flexible carriage inclination (0°/18°/25°)
- Innovative blade cover: Intelligent quick-close system for easy assembly and disassembly
- Powerful Bizerba motor
- Numerous carriage versions available

*Options

K-Class Flex II

- Customer display:
 - 12"/7" LCD color display
- Printer versions:
 - Dual printer for 2" ticket and 2" linerless paper
 - Dual printer for 2" ticket and 3" label paper
 - Printer for 3" label paper
 - Printer for 3" ticket or linerless paper
 - Printer for 2" linerless compact
- Epson TM-T 70 II
- VGA interface
- WLAN

GSP H

- Exclusive Ceraclean® surface finish
- Excellent gliding properties
- Easy product guidance
- Rapid cleaning
- Dishwasher safe
- Individual equipment:
 - Blade: Ceraclean® blade, cheese blade, bread blade
 - Numerous carriage versions
 - Blade changing device
 - Blade cover
 - Product fixation device
 - Placement (rubber feet, lifting device)
- Safety package:
 - Illumination: Visual display showing the current device mode
 - Automatic start/stop function via the slice thickness button

Dimensions

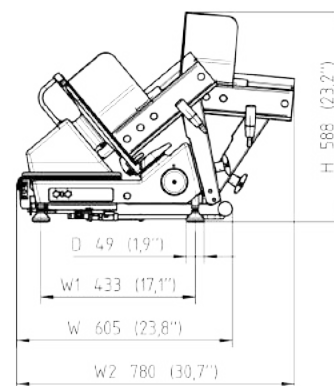
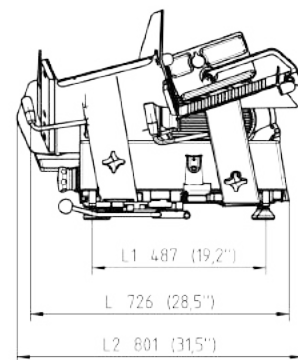

BIZERBA



GSP V

Highlights

- Hygienic design:
 - Large distance between blade and motor tower for easy cleaning by hand
 - Guided run-off of meat and product juices
 - Smooth, rounded surface without seams
 - Removable, dishwasher-safe sharpener
- 40° angled blade and 25° carriage inclination
- Innovative blade cover: Intelligent quick-close system for easy assembly and disassembly
- Powerful Bizerba motor

*Options

- Individual equipment:
 - Blade: Ceraclean® blade, cheese blade, bread blade
 - Placement (rubber feet, lifting device)
- Portion scale

Dimensions

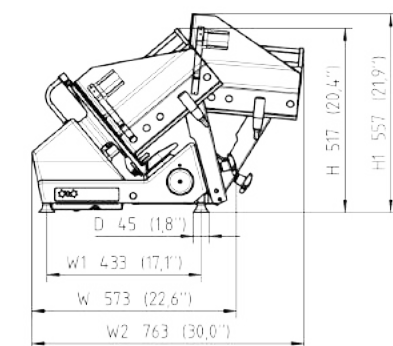
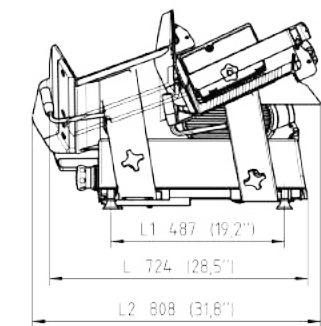

BIZERBA

GSP H Flex

GSP V

Perfect integration

The freedom to combine components and work ergonomically even in tight spaces: This is the GSP H Flex. No need to move between devices. Thus, it is easy to hold eye contact with the customer. Benefit from the multifunctionality to provide service, label products, handle transactions or provide information—In our opinion, that's the definition of perfect integration.



One modular design — many options



Multi-color customer display
TFT LCD with LED backlighting 7"



Multi-color customer display
TFT LCD with LED backlighting 12.1"



Multi-color operator display
TFT LCD with LED backlighting 12.1"



K-Class Flex printer



2" Linerless compact printer



K-Class Flex CPU control unit



VESA mounting system



K-Class Flex cash register drawer

For top quality and reliable performance

In your day-to-day work with the GSP gravity feed slicer, you can rely on high-quality cleaning products and original consumables in Bizerba quality. Everything is optimally aligned with your products ensuring the best possible results and longevity of your investment. Benefit from perfect team work.

Optimal functioning and constant availability of your devices and machines requires professional care. Our high-quality cleaning agents play an important role here since they are specifically developed for demanding conditions in retail, industry and gastronomy. They are easy to use and show impressive results: Perfect cleanliness providing protection as well as disinfecting hygiene for sensitive components and smooth surfaces alike. For every type of material, whether stainless steel, plastic or glass, we have a suitable cleaning agent in our comprehensive assortment. Clean solutions for your work area or production facility.



Information to suit your every need

There are various quick and effective routes to finding the perfect solution for your company. Whether you would like to contact us online or prefer to arrange a face-to-face meeting, Bizerba is always happy to help.

In person

If you would like to set up a personal meeting to discuss your on-site circumstances and possibilities, please contact us directly. Our customer advisors are always on hand to assist you, from the initial idea to detailed planning and from implementation to staff training. You can find details of how to contact us on the back page of this brochure.

for yourself thanks to videos and 360° animations. Simply visit our website to see more:

www.bizerba.com

Would you like to know more?

Are you keen to obtain more detailed information about Bizerba's products? If so, please do not hesitate to contact us. Whether you require scale drawings, technical details or interface specifications, we're happy to advise you.

Online

The Bizerba website provides a quick, easy and focused overview of all our product solutions as well as relevant topics relating to weighing, packaging, pricing and labeling. You can even experience our solutions from all angles 'virtually'

An overview of all possibilities

Product	What?						Application?			Application area?		Dimensions		Slicing performance		Max. product sizes	
	Sausages/cold cuts	Meat, fresh	Ham with bones	Cheese	Fruit/Vegetables	Bread	Preslicing	Presentation	Assisted sales	Retail area (counter)	Canteen kitchen/restaurant	Industrial	Blade Ø [mm]	Installation area [mm x mm]	Slices/min	Product sizes, round Ø [mm]	Product sizes □ [mm]
Vertical slicers, manual																	
VSC220	●	×	×	●	⊖	●	×	⊖	●	●	●	×	220	408×257		150	200 × 130
VSC280 (150 mm aluminum, one-part) open closed blade cover	●	×	×	●	⊖	●	×	⊖	●	●	●	×	280	503×371		195 170	230×170 230×160
VSC280 (150 mm transparent carriage) open closed blade cover	●	×	×	●	⊖	●	×	⊖	●	●	●	×	280	503×371		192 170	215×170 230×170
VS11	●	×	×	●	⊖	●	×	⊖	●	●	●	×	280	466×395		190	230×165
VS12	●	×	×	●	⊖	●	×	⊖	●	●	●	×	330	520×430		225	260×175
VS12 F 33	●	●	⊖	⊖	⊖	●	×	⊖	●	●	●	×	330	605×430		225	310×175
VS12 F 35	●	●	⊖	⊖	⊖	●	×	⊖	●	●	●	×	350	605×430		270	315×245
VS12 F 37	●	●	⊖	⊖	⊖	●	×	⊖	●	●	●	×	370	605×430		267	363×228
VS12 F – P	●	⊖	●	×	×	●	×	⊖	●	●	●	×	350	605×430		263	307×237
VS12 F – P 37	●	⊖	●	×	×	●	×	⊖	●	●	●	×	370	605×430		263	335×228
Vertical slicers, fully automatic/semi-automatic																	
VS11 A (with product depositing)	●	×	×	●	⊖	×	●	●	●	●	●	×	280	462×395		145	230×145
VS11 A (w/o product depositing)	●	×	×	●	⊖	×	●	●	●	●	●	×	280	462×395		190	230×145
VS12 A (with product depositing)	●	×	×	●	⊖	×	●	●	●	●	●	×	330	515×430		180	240×175
VS12 A (w/o product depositing)	●	×	×	●	⊖	×	●	●	●	●	●	×	330	515×430	30 – 70	225	260×175
VS12 D (with product depositing)	●	×	×	●	×	×	●	●	⊖	●	●	●	330	515×430	30 – 70	180	240×175
VS12 D (w/o product depositing)	●	×	×	●	×	×	●	●	⊖	●	●	●	330	515×430	30 – 70	225	260×175
A400	●	×	×	●	×	×	●	●	⊖	●	●	●	330	410×490	30 – 55	180	240×170
Industrial slicers																	
A400 openWorld	●	×	×	●	×	×	●	●	⊖	⊖	●	●	330	410×490	30 – 55	180	240×170
A550	●	⊖	×	●	×	⊖	●	⊖	×	×	⊖	●	420	1281×800	250	180	210×180
A650	●	⊖	×	●	×	⊖	●	⊖	×	×	⊖	●	420	1281×800	300	180	210×180 275×150
Gravity feed slicers, manual																	
GSC280 (150 mm aluminum, one-part) open closed blade cover	●	×	×	●	●	●	×	⊖	●	●	●	×	280	535×423		165 145	230×120 230×100
GSP V (25° Low, EU) open blade cover	●	×	×	●	●	●	×	⊖	●	●	●	×	330	532×478		228	290×160
GSP V (25° High, USA) open blade cover	●	×	×	●	●	●	×	⊖	●	●	●	×	330	532×478		202	290×126
GSP H 0° open closed blade cover	●	⊖	×	●	●	●	×	⊖	●	●	●	×	350	532×478		260 235	290×246 290×235
GSP H 18° open closed blade cover	●	⊖	×	●	●	●	×	⊖	●	●	●	×	330	532×478		235 220	290×188 290×160
GSP H 25° Low open closed blade cover	●	⊖	×	●	●	⊖	×	⊖	●	●	●	×	330	530×480		228 210	290×160 290×130
GSP H 25° High open closed blade cover	●	⊖	×	●	●	⊖	×	⊖	●	●	●	×	330	530×480		202 180	290×126 290×100
Gravity feed slicers, fully automatic/semi-automatic																	
GSP HD 18° Low open closed blade cover	●	●	×	●	●	●	●	●	●	●	●	●	330	532×444		235 220	290×188 290×160
GSP HD 18° Low – clamping carriage open closed blade cover	●	●	×	●	●	●	●	●	●	●	●	●	330	532×444		208 208	270×153 270×130
GSP HD 25° Low open closed blade cover	●	●	×	●	●	●	●	●	●	●	●	●	330	532×444		228 210	290×160 290×130
GSP HD 25° High open closed blade cover	●	●	×	●	●	●	●	●	●	●	●	●	330	532×444		202 180	290×126 290×100

Legend

- Optimally suitable for this purpose
- ⊖ Suitable for this purpose
- ×

Semi-automatic machine: Automatic depositing – manual carriage, e.g. VS11 A and VS12 A
 Automatic machine: Automatic depositing – automatic carriage, e.g. VS12 D