

SLICING

NELLA**825E-PLUS**
GRAVITY FEED SLICER

Model 825E-PLUS

**STANDARD FEATURES**

- 1-speed, ¼ HP, totally enclosed and permanently lubricated knife motor.
- Furnished in 115/60/1, 2.5 amps, AC, ETL listed.
- Finish is stainless steel and sanitary anodized aluminum; unit disassembles quickly without tools for easy cleaning.
- 30° product table with removable meat pusher.
- Nominal 10" (250 mm) diameter; hollow ground, hardened and polished forged chromium-plated carbon steel knife.
- Carriage handles food up to 8¼" (210 mm) wide, by 6⅞" (175 mm) high or 6⅞" (175 mm) diameter.
- Precise slice adjustment to a thickness of 9/16" (14 mm).
- Top-mounted, two stone knife sharpener produces a consistently sharp knife edge.
- Permanent, tapered knife ring guard covers non-slicing portion of knife even when the center plate is removed; ring guard design provides more room behind the knife for easy cleaning.
- Positive, moisture protected, on/off switch with power light indicator.
- Attached 6-foot, flexible, 3-wire cord and plug for grounded receptacle (5-15P).

FEATURES

Berkel Model 825E-PLUS manual gravity feed slicer features Berkel's hollow ground chromium-plated, carbon steel knife and built-in sharpener. The permanent, tapered guard covers the non-slicing portion of the knife, even when the center plate is removed. The 30° table makes product feed easier, creating more consistent and uniform slices with less waste. The ¼ HP motor, 10" knife and large product table are ideal for handling oversize meats, cheeses and a variety of other products. The 825E-PLUS is easy to clean and disassembles quickly without tools. The compact space-saving design is ideal for limited kitchen counter space.

COMPLIES WITH NSF/ANSI STANDARD #8

NELLA

825E-PLUS GRAVITY FEED SLICER

SPECIFICATIONS

Motor: 1-speed, ¼ HP, totally enclosed, permanently lubricated ball bearings, thermally protected.

Electrical: Furnished in 115/60/1, 2.5 amps, AC, ETL listed.

Finish/Construction: All food contact areas are stainless steel or anodized aluminum including the pusher, gauge plate, product table, center plate, knife ring guard and one-piece base. Slicer disassembles quickly without tools for easy cleaning.

Knife: Nominal 10" (250 mm) diameter, hollow ground, hardened and polished forged chromium-plated carbon steel, rotates at 290 rpm.

Cutting Capacity: Carriage handles food up to 8¼" (210 mm) wide by 6⅞" (175 mm) high or 6⅞" (175 mm) diameter.

Slice Thickness: Precision system provides infinite slice adjustment and consistent cuts of hard or soft foods from tissue thin to ⅞" (14 mm).

Full Gravity Feed: Full 30° angle feed requires less mechanical pressure. Equipped with removable anodized aluminum pusher to hold product and minimize waste.

Knife Sharpener: Top mounted, two stone system for a lasting, razor-sharp edge.

Knife Ring Guard: Permanent, tapered guard covers non-slicing portion of knife edge even when the center plate is removed. The ring guard is designed to provide added room behind the knife for easy cleaning.

On/Off Switch: Highly reliable, moisture resistant, on/off switch with power light indicator.

Cord and Plug: Attached 6-foot, flexible, 3-wire cord and plug for grounded receptacle (5-15P).

Warranty: All parts, service and travel coverage for one year, excluding wear items.

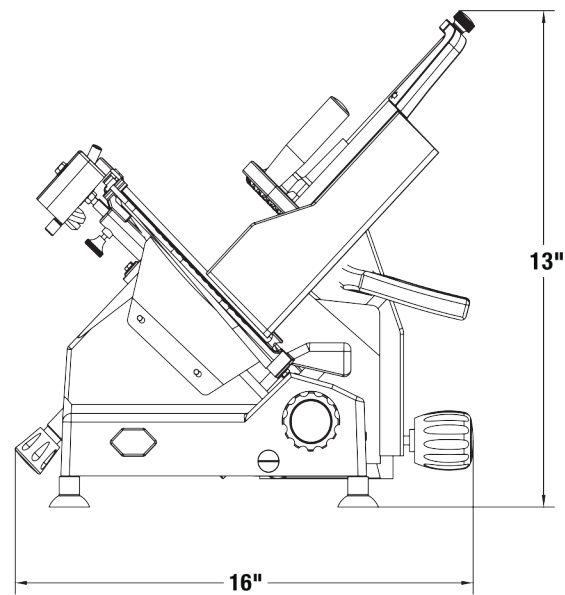
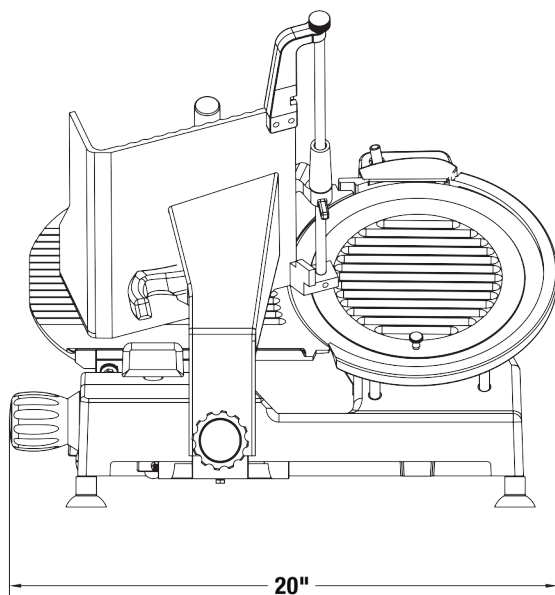

MODEL NUMBER	CUTTING CAPACITY	SLICE THICKNESS	KNIFE DIA.	PRODUCT DIMENSIONS		
				WIDTH	DEPTH	HEIGHT
825E-PLUS	8¼" (210 mm) wide 6⅞" (175 mm) high 6⅞" (175 mm) diameter	to ⅞" (14 mm)	10" (250 mm)	16" (407 mm)	20" (510 mm)	13" (330 mm)

MODEL NUMBER	MOTOR	ELECTRICAL	WEIGHT	BOX DIMENSIONS		
				WIDTH	DEPTH	HEIGHT
825E-PLUS	1-speed ¼ HP	115/60/1 2.5 amps	Net 33 lbs. (15 kg) Ship 40 lbs. (18 kg)	22" (560 mm)	24" (610 mm)	18" (458 mm)

NOTE: As we continually strive to improve our products, specifications are necessarily subject to change without notice.