

**CUSTOMER CONVENIENCE****36-GALLON TRASH RECEPTACLE**

Omcan's trash receptacle with swing door provides the excellent compact solution for waste management. It is the perfect companion for restaurants, healthcare facilities, schools, offices, and hotels. Features an engraved message to reiterate the gratitude towards your customers as well as a recessed top for discarded food trays.

# 36-GALLON TRASH RECEPTACLE

## FEATURES

- Fits Standard 36 gallon / 3.78 litres bin
- Laminated melamine
- Hinged opening with engraved "thank you" message
- Food tray holder on top area
- Swing door for ease of cleaning

## SPECIFICATION

	NATURAL	BLACK
COLOR		
DEPTH	22" (558.80MM)	
WIDTH	22" (558.80MM)	
HEIGHT	47" (1193.80)	
MATERIAL	PLYWOOD / MELAMINE	
NET WEIGHT	43KGS / 94.80 LBS	
GROSS WEIGHT	45KGS / 99.20 LBS	
PACKAGING DIMENSIONS	47" X 22" X 4.72" / 200 X 570 X 120MM	

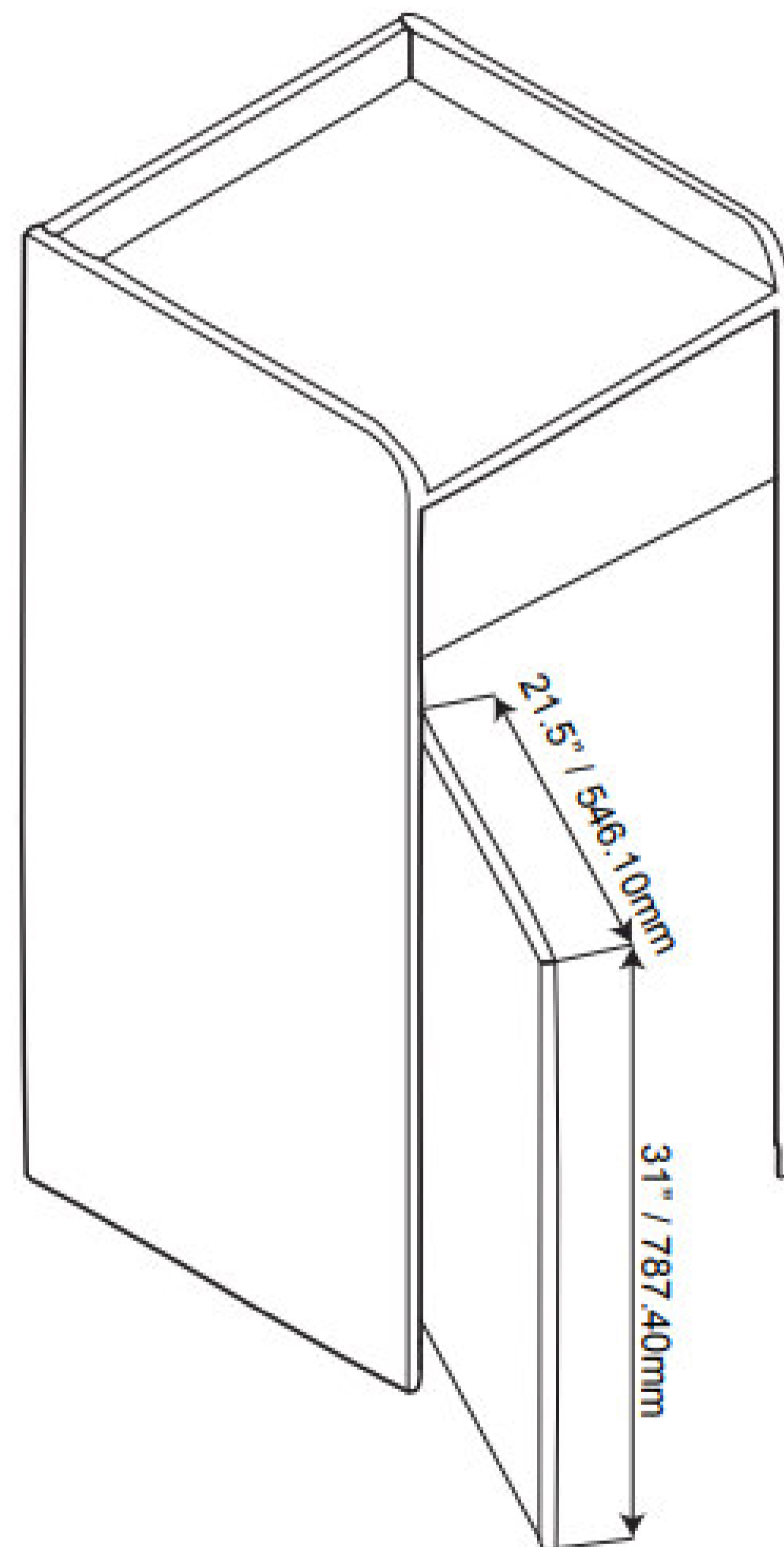
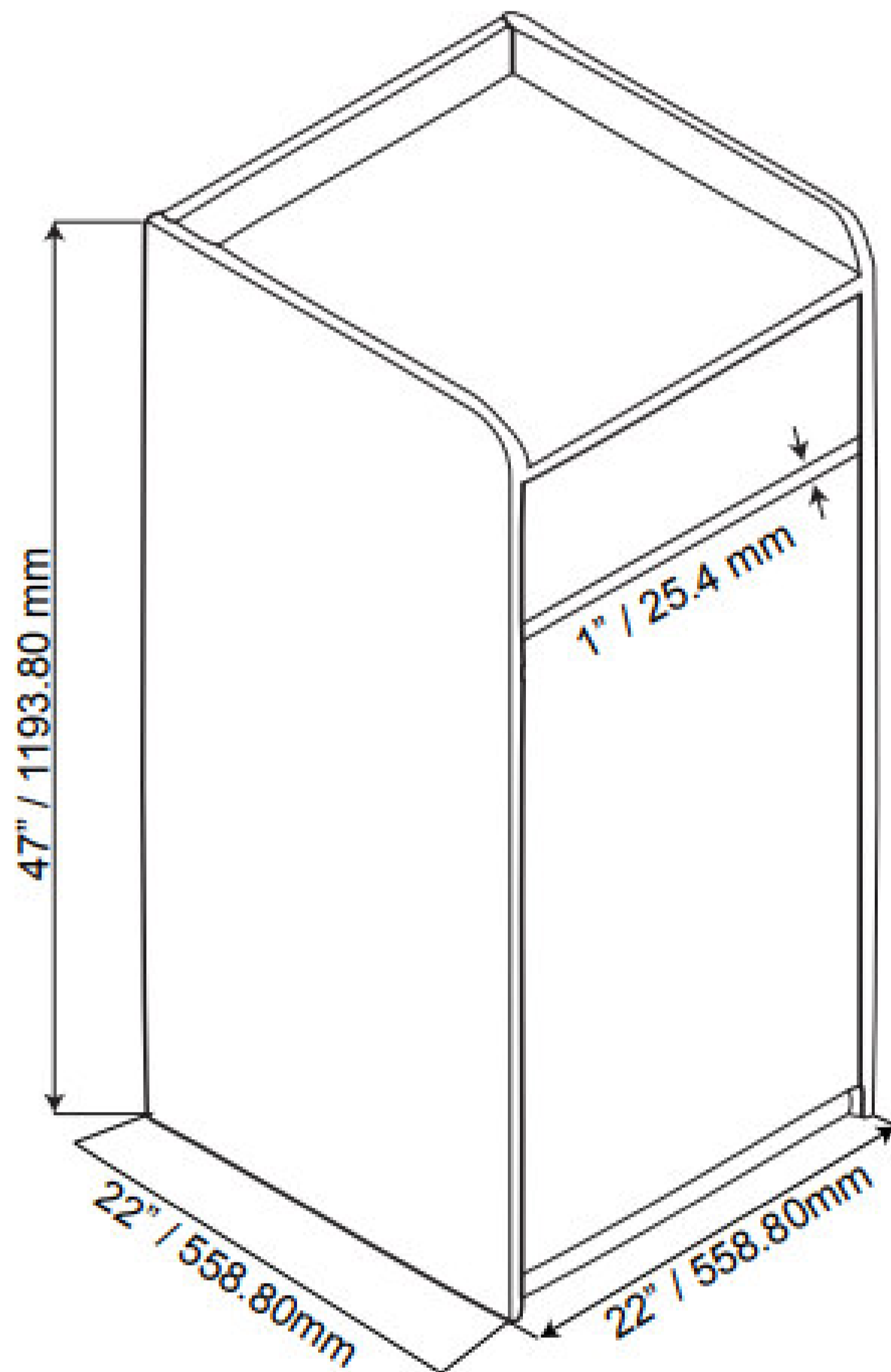

**NELLA**

WWW.NELLAONLINE.COM  
HELP@NELLAONLINE.COM

LOCATIONS

148 NORFINCH DR  
NORTH YORK, ON,  
M3N 1X8  
416-740-2424

433 QUEEN ST E.  
TORONTO, ON,  
M5A 1T5  
416-847-1112

1164 ELLESMERE ROAD  
SCARBOROUGH, ON,  
M3N 1X8  
416-292-0828