

### 30-LITER BOWL CUTTER



Bowl cutting produces as much as 15% higher finished product yield. Bowl cutting also allows the use of up to 30% more water and results in less shrinkage.

#### FEATURES



REMOVABLE FRICTION LID/BOWL BAND



REMOVABLE KNIFE HEAD WITH 3 KNIVES (STANDARD)



EMERGENCY STOP BUTTON



TRANSPARENT NOISE PROTECTION COVER



OPTIONAL 6-KNIFE HEAD

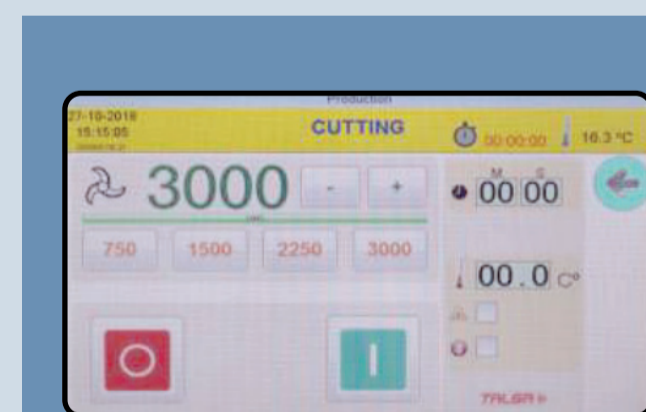

7" DIGITAL TOUCH SCREEN

# 30-LITER BOWL CUTTER

## FEATURES

- 7" digital touch screen displaying knife speed, temperature and time
- Variable speed control and 4 speed preselection buttons
- Programmable automatic stop triggered by elapsed time or temperature limit
- Emergency stop button
- Motor with electronic drive and overload protection
- Removable 3-knife head, optionally with 6 knives
- All stainless steel construction, solid s/s bowl and lid
- Adjustable, on-slip and vibration absorbing machine feet
- Transparent noise protection cover
- Removable friction lid/bowl band for easy cleaning, with self-adjusting springs
- Removable friction lid/bowl band for easy cleaning, with self-adjusting springs

## TECHNICAL DRAWINGS

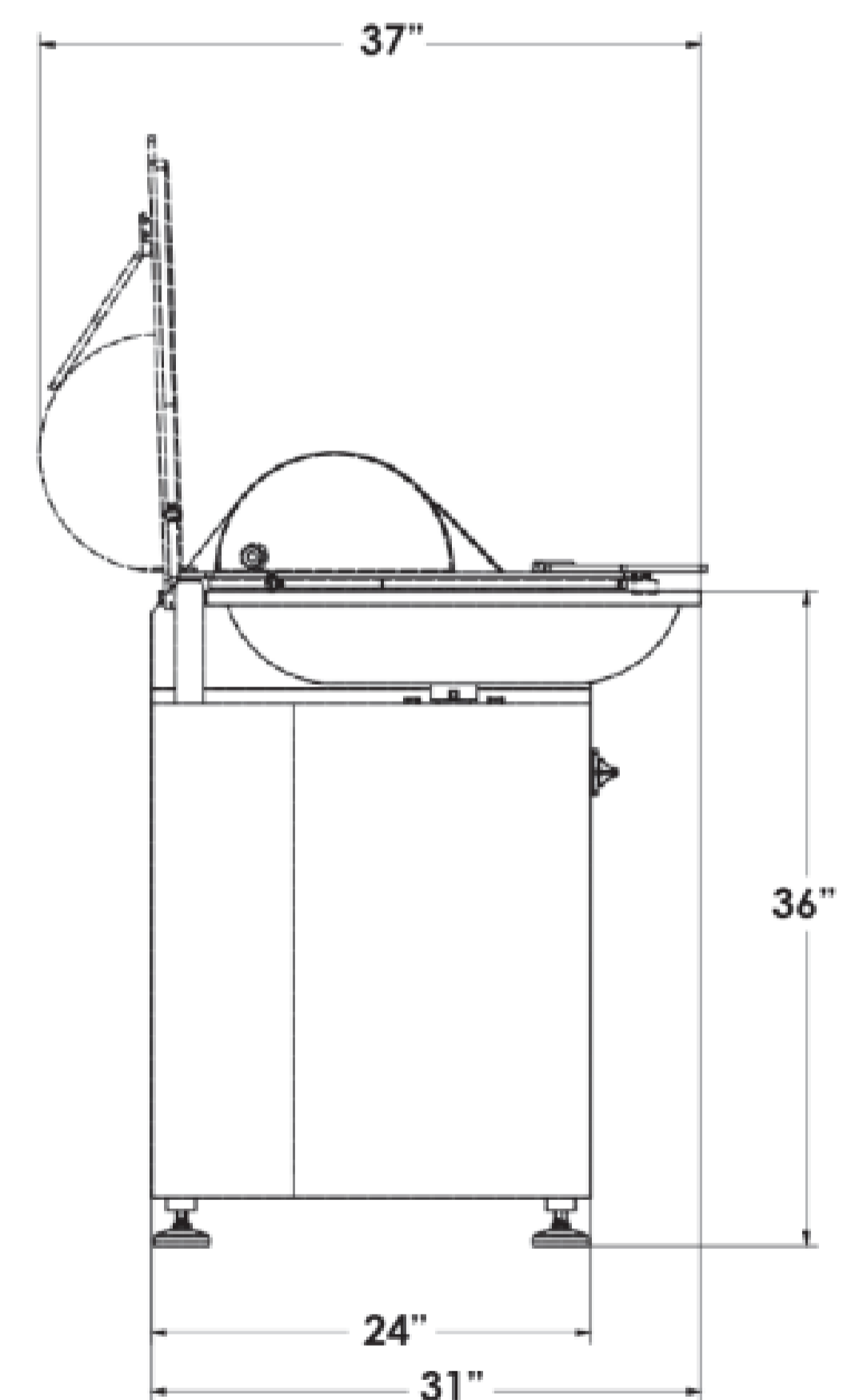
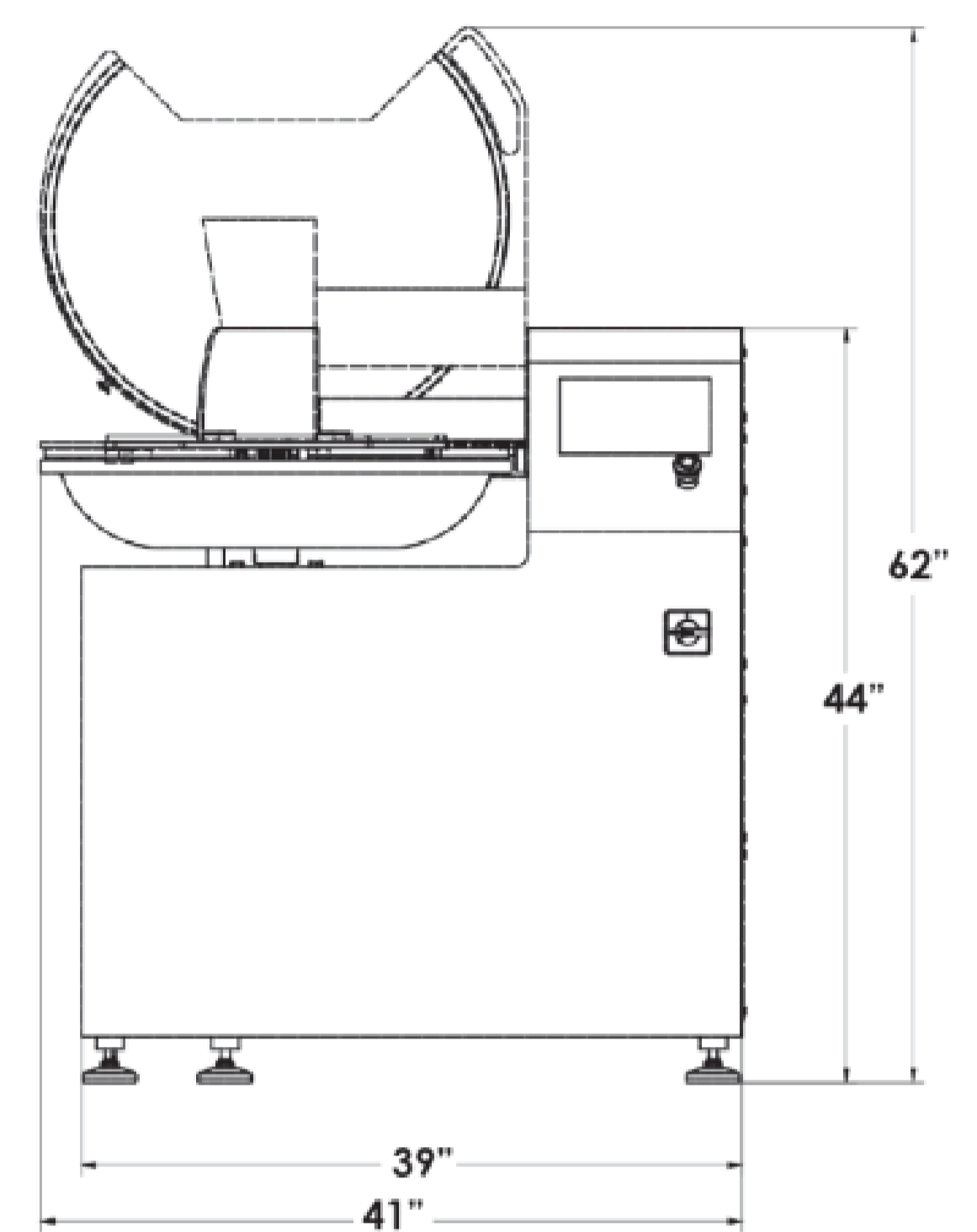

### TECHNICAL SPECIFICATIONS

<b>BOWL VOLUME</b>	30 L (8 Gal.)
<b>MIXTURE BOWL CAPACITY</b>	Soft Meat: ± 5-22 kg (± 11-48 lbs) Dogged Meat: ± 5-15 kg (± 11-33 lbs)
<b>KNIFE SPEED</b>	Variable: 750 to 3000 RPM
<b>LINEAR KNIFE SPEED</b>	15-44 m/s
<b>POWER</b>	7.5 HP / 5.6 kW
<b>ELECTRICAL</b>	208V / 60Hz / 3Ph
<b>DIMENSIONS (DWH)</b> <i>If lid is open</i>	37" x 41" x 62" 930 x 1040 x 1560 mm
<b>NOISE LEVEL AT 1M</b>	±330 kg. / 728 lbs.

**NELLA**

WWW.NELLAONLINE.COM  
HELP@NELLAONLINE.COM

#### LOCATIONS

**148 NORFINCH DR  
NORTH YORK, ON,  
M3N 1X8  
416-740-2424**

**433 QUEEN ST E.  
TORONTO, ON,  
M5A 1T5  
416-847-1112**

**1164 ELLESMERE ROAD  
SCARBOROUGH, ON,  
M3N 1X8  
416-292-0828**