

COLUMN HEATER

**KEEPING YOUR GUESTS
WARM IN ANY
COLD DAYS AND NIGHTS
WITH OUR
SLEEK DESIGNED
COLUMN HEATER**

FEATURES

- Powder coated frame
- High Efficiency Carbon Fibre Heating Element
- Power: 1500 Watts
- Two Power Settings
- (One heating element only)
- Powder Coated Base
- 360-degree tip-over Safety Switch
- IP24 Approved

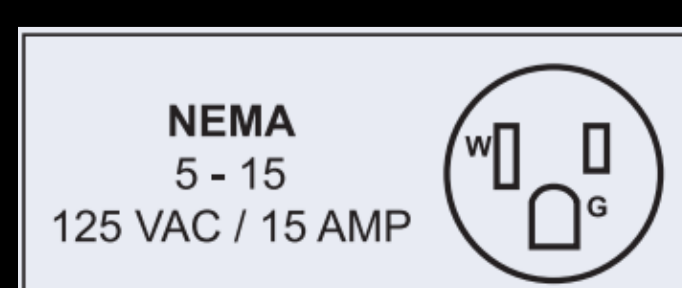

**1 YEAR
WARRANTY**
PARTS AND LABOUR

COLUMN HEATER

TECHNICAL DRAWINGS WITH DETAILED DIMENSIONS

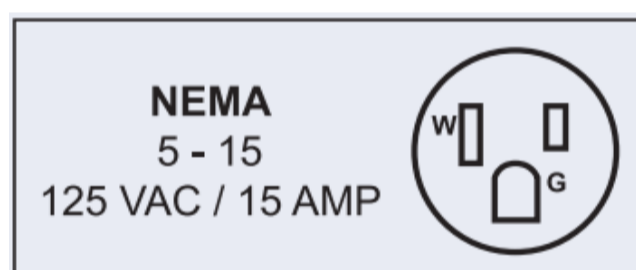
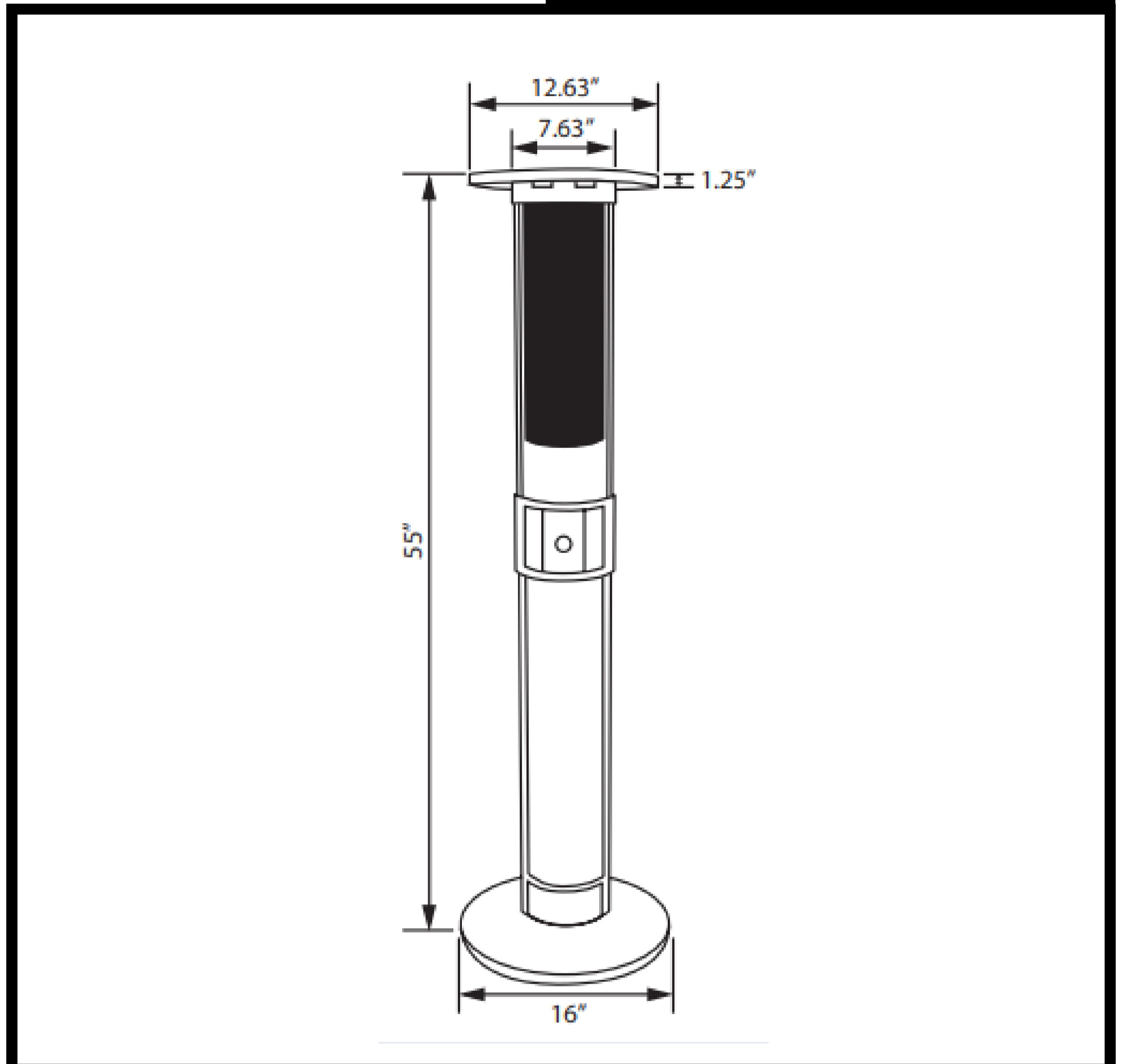

SPECIFICATION

DESCRIPTION
 POWER
 ELECTRICAL
 DIMENSIONS(DWH)
 NET WEIGHT
 GROSS WEIGHT
 GROSS DIMENSIONS

COLUMN HEATER

1.5 KW
 120V / 60HZ / 1PH
 16" X 16" X 55" / 406 X 406 X 1397 MM
 29.92 LBS. / 13.6 KG.
 39.16 LBS. / 17.8 KG.
 31.10" X 18.50" X 12.59" / 790 X 470 X 320 MM



WWW.NELLAONLINE.COM
 HELP@NELLAONLINE.COM

LOCATIONS

148 NORFINCH DR
 NORTH YORK, ON,
 M3N 1X8
 416-740-2424

433 QUEEN ST E.
 TORONTO, ON,
 M5A 1T5
 416-847-1112

1164 ELLESMERE ROAD
 SCARBOROUGH, ON,
 M3N 1X8
 416-292-0828