

FOOD EQUIPMENT**88" STAINLESS STEEL COUNTERTOP REVERSIBLE
DOUGH SHEETER****Serial No.:**458628384215400**Model No.:**100-1056827**EFFICIENT EQUIPMENT PERFECT FOR YOUR BAKERY**

Suitable for bakeries, restaurants, and hotels, Omcan's dough sheeter is designed for optimal performance. Equipped with safety features, preset roller thickness controls, and foldable tables for space saving storage, this machine increases your bakery's production and efficiency. Safe to operate and easy to clean.

1 YEAR
WARRANTY
PARTS AND LABOUR

STAINLESS STEEL COUNTERTOP REVERSIBLE DOUGH SHEETER

Technical Drawing

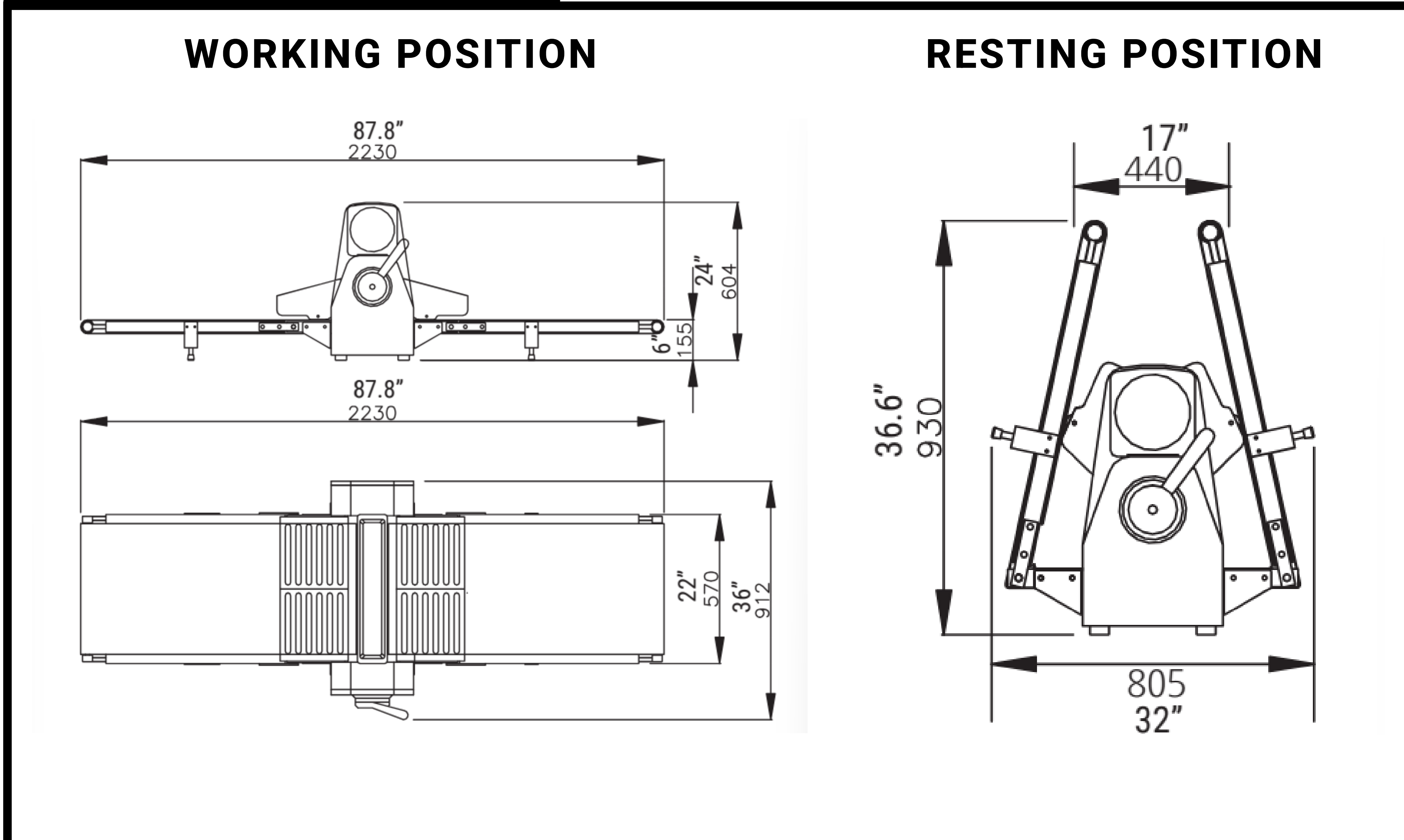

Serial No.:458628384215400
Model No.:100-1056827

Features

- Made of high quality stainless steel; ideal use for long period of time
- Fixed conveyor speed
- Roller adjustments are manual
- Suitable for bakeries, restaurants, and hotels
- Equipped with preset roller thickness control and foldable tables for space-saving storage
- Equipped with preset roller thickness control and foldable tables for space-saving storage

DESCRIPTION	Countertop dough sheeter, stainless steel
ELECTRICAL	220V/60 Hz/1 Ph
POWER	0.75 HP / 0.55 kW
ROLLER SIZE	2"/51mm (Dia.), 29.75"/755.65mm (W)
ROLLER ADJUSTABLE GAP	1 - 35 mm
CONVEYER BELT WIDTH	19.75"/ 501.7 mm
CONVEYER WIDTH	22.5"/ 571.5 mm
CONVEYER BELT SPEED	18m/min - 32m/min
ROLLER SPEED	124r/min
MAXIMUM DOUGH CAPACITY	5 kg/ 11 lbs.
WORKING POSITION DIMENSION (DWH)	36" x 88" x 24" 912 x 2230 x 604 mm
RESTING POSITION DIMENSION (WH)	32" x 37" 805 x 930 mm
WEIGHT	125 kg. / 275.6 lbs.
GROSS WEIGHT	155 kg. / 341 lbs
GROSS DIMENSIONS	38" x 29" x 41"/ 965 x 736.6 x 1016 mm



WWW.NELLAONLINE.COM
HELP@NELLAONLINE.COM

ADDRESS
**148 NORFINCH DR,
 NORTHYORK, ON, M3N 1X8**
 PHONE
416-740-2424

**433 QUEEN ST E.,
 TORONTO, ON, M5A 1T5**
416-847-1112

**1164 ELLESMERE ROAD,
 SCARBOROUGH, ON, M3N 1X8**
416-292-0828