

# NELLA // COUNTERTOP MERCHANDISER

SERVING THE FOOD INDUSTRY SINCE 1951

## 35L & 50L CAPACITY DISPLAY WARMERS

Item: 41869  
Model: DW-CN-0035

Item: 41871  
Model: DW-CN-0050

DISPLAY WARM MERCHANDISE

Increase impulse **Sale**



**WARRANTY**  
PARTS AND LABOR



Authorized Dealer

# COUNTERTOP MERCHANDISER

## 35L & 50L CAPACITY DISPLAY WARMERS

# NELLA

### Features:

- Adjustable temperature controller
- Non-adjustable chrome plated shelf
- Stainless steel construction
- Temperature range: 30-90°C / 86-194°F



**Model DW-CN-0035**

- Single shelf unit
- Constructed with 1 front, 1 back hinged door
- Comes with 1 non-adjustable chrome plated shelf

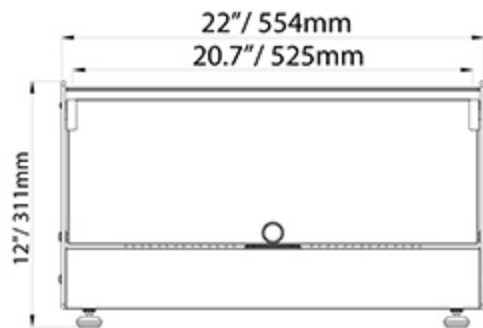
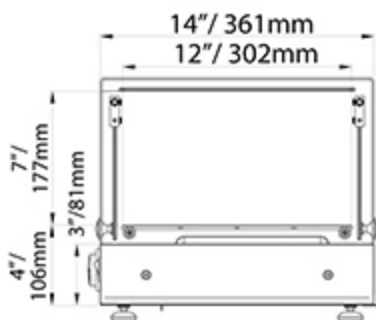

**Model DW-CN-0050**

- Dual shelf unit
- Constructed with 2 front, 2 back hinged doors
- Comes with 2 non-adjustable chrome plated shelves

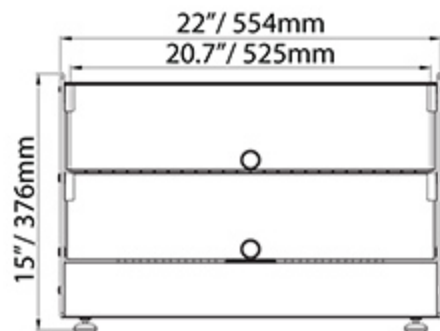
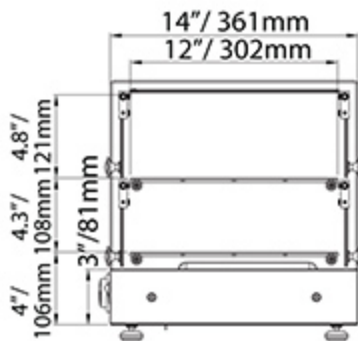

### TECHNICAL SPECIFICATIONS

ITEM NUMBER	41869	41871
MODEL	DW-CN-0035	DW-CN-0050
STORAGE VOLUME	35L	50L
TEMPERATURE RANGE	30 - 90°C / 86-194°F	30 - 90°C / 86-194°F
POWER	800W	800W
RATED CURRENT	6.8 A	6.8 A
ELECTRICAL	110V / 60Hz	110V / 60Hz
NET DIMENSIONS (DWH)	22" x 14" x 12" / 554 x 361 x 311 mm	22" x 14" x 15" / 554 x 361 x 376 mm
NET WEIGHT	26 lbs. / 11.8 kgs.	30.2 lbs. / 13.7 kgs.
GROSS DIMENSIONS	24.6" x 17.4" x 14.3" / 624 x 442 x 362mm	24.6" x 17.4" x 16.8" / 624 x 442 x 427mm
GROSS WEIGHT	42 lbs. / 19 kg.	47 lbs. / 21.3 kg.

# NELLA

Telephone: 416-740-2424  
 Email: [help@nellaonline.com](mailto:help@nellaonline.com)  
 Website: [www.nellaonline.com](http://www.nellaonline.com)