



Outperform every day.™

Project:
Item Number:
Quantity:

CAYENNE® GAS HOT PLATES



40736



40737

Cayenne® Gas Hot Plates

DESCRIPTION

Vollrath's Cayenne® Gas Hot Plates provide a simple and effective way to prepare food with high efficiency in an economical, safe and easy way. Ideal for use in steak houses, restaurants, coffee shops, clubs and pubs.

CLEARANCE AND POSITIONING

This appliance must be installed adjacent to non-combustible surfaces only, with a minimum of 6" (15.2 cm) from all sides. This appliance must be a minimum distance of 6" (15.2 cm) from another appliance. The appliance must have the supplied 4" (10.2 cm) legs installed and be placed on a non-combustible surface.

ITEMS

Item No.	Model No.	Description
40736	HPA1002	12" Gas Hot Plate
40737	HPA1004	24" Gas Hot Plate
40738	HPA1006	36" Gas Hot Plate

FEATURES

- Shipped natural gas - includes kit with regulator for field conversion to propane
- Superior burners for fast heating and even heat distribution
- 26,000 BTU per burner
- Stainless and aluminized steel with fully-welded construction for durability and long life
- All metal knobs and knob guards protect gas valves from damage and won't break or crack and are **GUARANTEED FOR LIFE**
- Front access openings for lighting of pilot lights
- Each burner has a separate individual grate for easier handling and cleaning
- Front-back 12" model (40736) offers narrow footprint for tight counter spaces
- Full-width stainless steel drip pan
- Bull-nose design to protect from burns
- Heavy-duty legs with leveling adjustment
- ¾" NPT gas inlet

Agency Listings



Due to continued product improvement, please consult www.vollrath.com for current product specifications.

WARRANTY: All models shown come with Vollrath's standard warranty against defects in materials and workmanship. For full warranty details, please refer to www.Vollrath.com.

Approvals	Date



Outperform every day.™
www.vollrath.com

The Vollrath Company, L.L.C.
1236 North 18th Street
Sheboygan, WI 53081-3201 U.S.A.
Customer Service: 800.628.0830
Canada Customer Service: 800.695.8560
Main Fax: 800.752.5620 or 920.459.6573

Technical Services: 800.628.0832
Technical Services Fax: 920.459.5462

CAYENNE® GAS HOT PLATES

DIMENSIONS (Shown in inches (cm)).

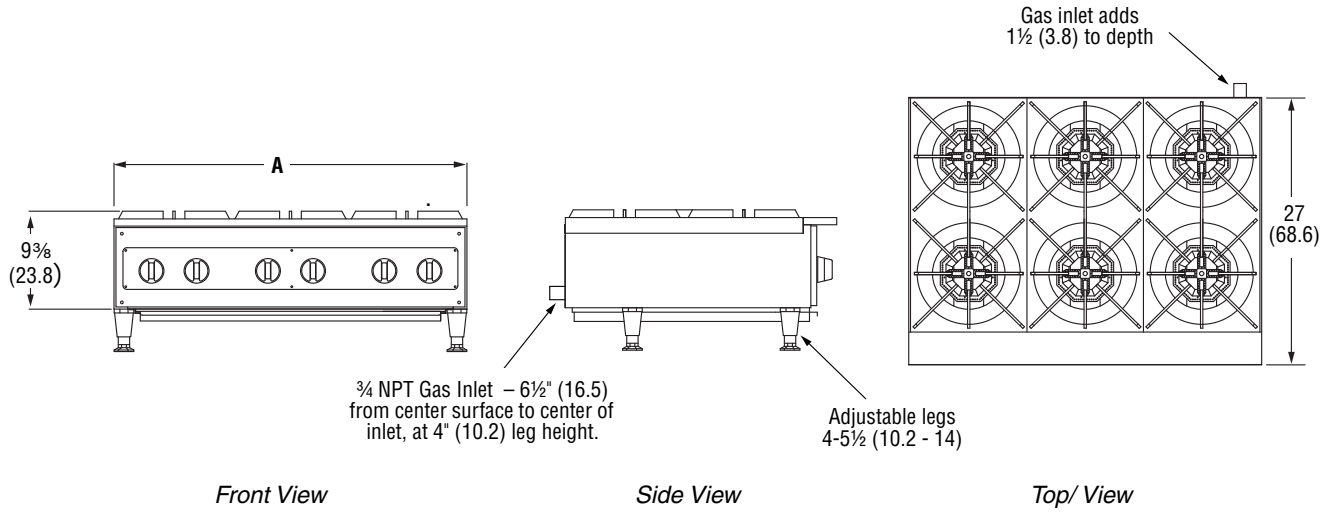

SPECIFICATIONS

Item	(A) Width	Output (BTU)	Number of Burners	Control Type	Pilot Type	Number of Drip Trays	Ship Weight Lb (Kg)
40736	12 (30.5)	52,000	2 (front and back)	Manual	Standing	1	96 (43.5)
40737	$23\frac{5}{8}$ (59.9)	104,000	4	Manual	Standing	1	169 (76.7)
40738	$35\frac{1}{2}$ (90.2)	156,000	6	Manual	Standing	1	228 (103.4)



Outperform every day.™

www.vollrath.com

The Vollrath Company, L.L.C.
 1236 North 18th Street
 Sheboygan, WI 53081-3201 U.S.A.
 Customer Service: 800.628.0830
 Canada Customer Service: 800.695.8560
 Main Fax: 800.752.5620 or 920.459.6573

Technical Services: 800.628.0832
 Technical Services Fax: 920.459.5462