

# NELLA

Serving Canada Since 1951

WWW.NELLAONLINE.COM

## FOOD EQUIPMENT

### FLOOR MODEL BAND SAW



NEMA  
6 - 20  
250 VAC / 20 AMP  
RECEPTACLE

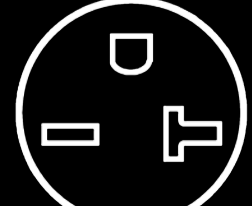

MADE IN BRAZIL



**1**  
YEAR

**1 YEAR**  
**WARRANTY**  
PARTS AND LABOUR

# TABLE TOP MEAT GRINDER

## TECHNICAL DRAWINGS WITH DETAILED DIMENSIONS

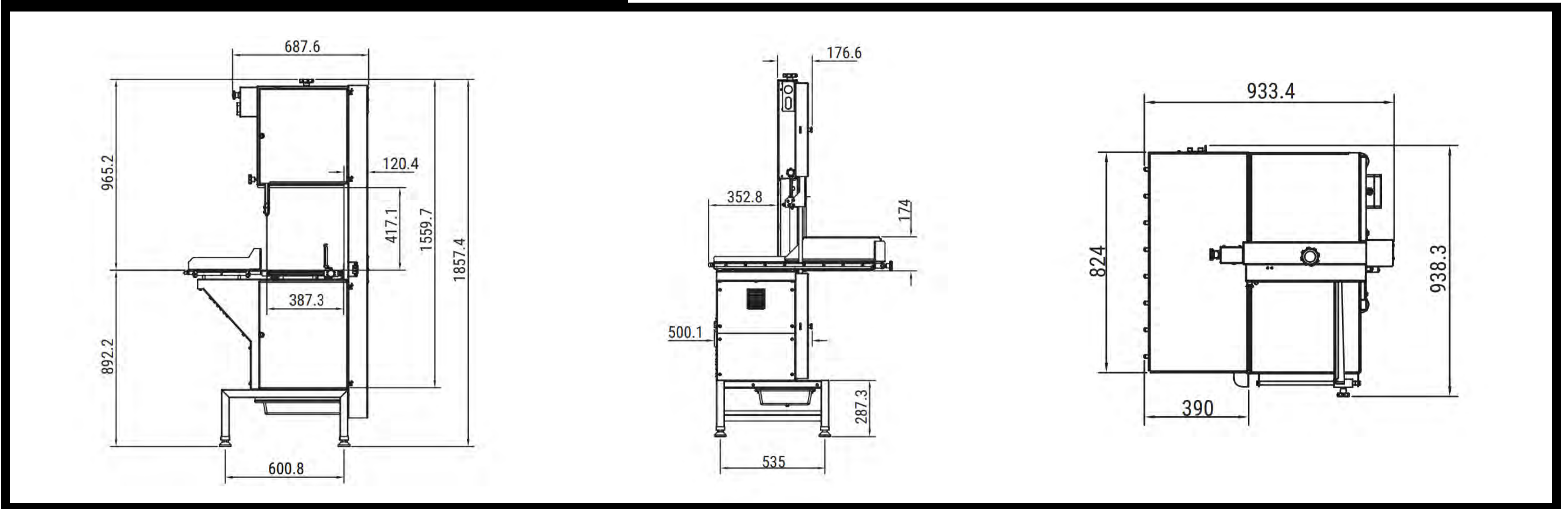

## TECHNICAL SPECIFICATIONS

DESCRIPTION	FLOOR MODEL
CONSUMPTION	2.2 kW.h
BLADE LENGTH	124"
CUTTING CAPACITY (HXW)	14 1/8" x 12 1/4"
VOLTAGE	230 V
FREQUENCY	60 Hz
PHASE	SINGLE PHASE
POWER RATING	3 HP
HEIGHT	72 7/8"
WIDTH	42 1/8"
DEPTH	36 1/4"
NET WEIGHT	264.00 lb

**NELLA**

WWW.NELLAONLINE.COM  
HELP@NELLAONLINE.COM

LOCATIONS

148 NORFINCH DR  
NORTH YORK, ON,  
M3N 1X8  
416-740-2424

433 QUEEN ST E.  
TORONTO, ON,  
M5A 1T5  
416-847-1112

1164 ELLESMERE ROAD  
SCARBOROUGH, ON,  
M3N 1X8  
416-292-0828