

Serving Canada Since 1951



### Features:

- 5.58 cu.ft oven capacity
- Stainless steel front, sides, and back
- 6" stainless steel adjustable heavy duty legs
- 6 heavy duty burners: 30,000 BTU each
- 6 x heavy duty flat cast-iron cooking grate
- Stainless steel pilot for durability
- Pull out crumb tray with rounded edges to prevent heat transfer
- Oven thermostat adjusts from 250°F to 550°F (121°C - 288°C)
- Oven Power: 1 x 31,000 BTU/hr.

Serial No.:455925684315100  
Model No.:100-786557

OVEN CAPACITY	5.58 cu. ft.
NUMBER OF BURNERS	6
POWER	30,000 BTU per burner 31,000 BTU (oven)
TOTAL INPUT BTU PER HR	211,000 BTU
OVEN TEMPERATURE	250°F - 550°F / 121°C - 288°C
DIMENSIONS (WDH)	36" x 32.6" x 61" 915 x 828.6 x 1538.5 mm
PACKAGING DIMENSIONS	41" x 40" x 44" 1040 x 1010 x 1120 mm
WEIGHT	368 lbs. / 167 kg.
PACKAGING WEIGHT	456 lbs. / 207 kg.

Item shipped on pallet



### TECHNICAL DRAWING WITH DIMENSIONS

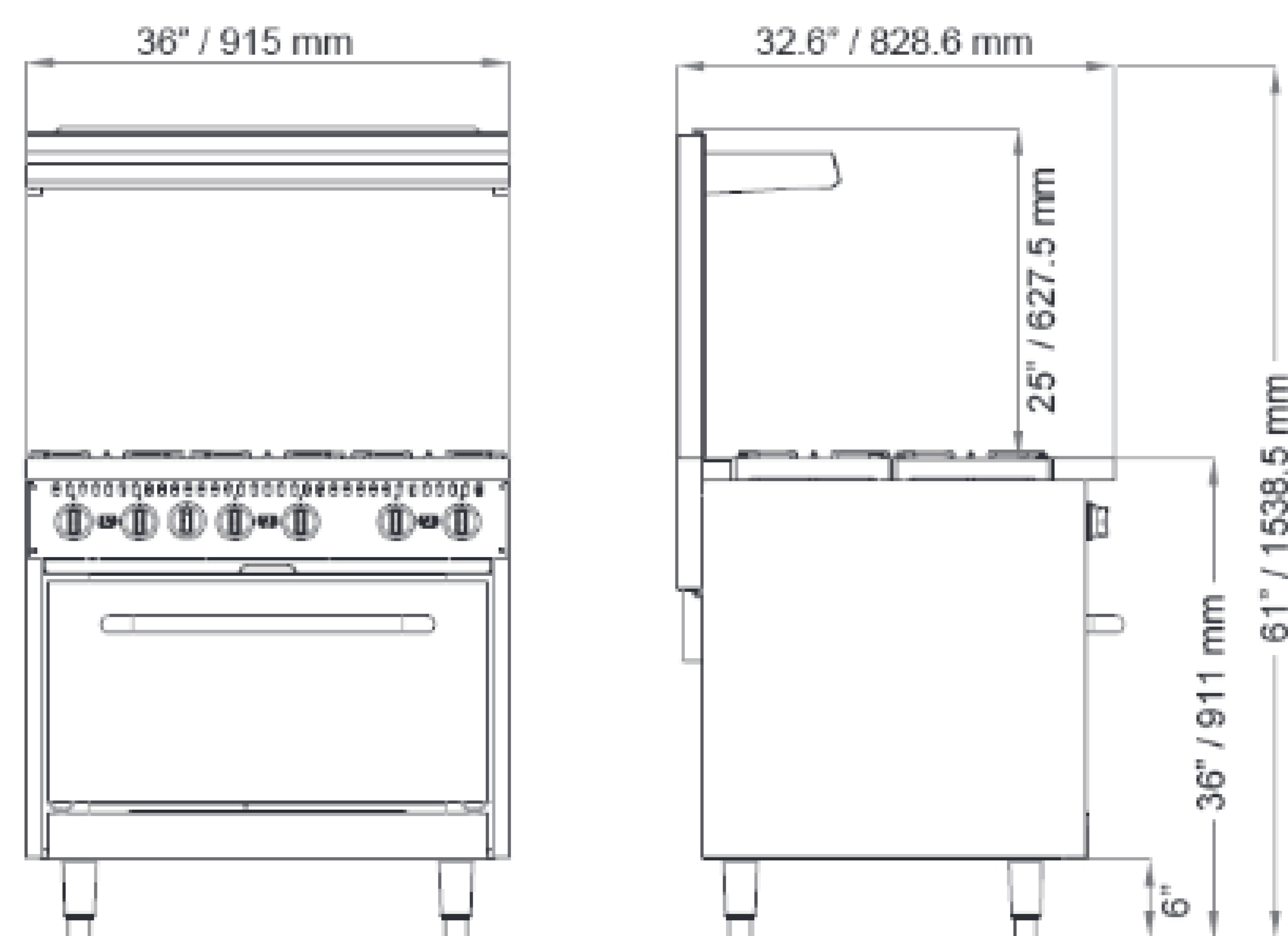

<https://www.nellaonline.com/products/nella-36-natural-gas-commercial-range-and-oven-1200-217>