



Serving Canada Since 1951

# 49-INCH GLASS DOOR FREEZERS WITH 2 DOORS

Serial No.:458248005003100

Model No.:100-1018789

**This commercial freezer is designed to provide high performance and efficiency. It features self closing glass doors and high density polyurethane insulation.**

**Features:**

- Outside material: Painted steel
- LED lighting
- Self-closing doors
- Removable door gasket
- Plastic coated steel shelves with shelf tag holder
- Automatic defrosting



POWER	0.75 HP
NET VOLUME	29 cu.ft. / 830 liters
SHELF CAPACITY	90 lbs. / 41 kg.
TEMPERATURE RANGE	-23°C - -18°C / -10°F - 0°F
REFRIGERANT	R290
ELECTRICAL	110V/60Hz/1Ph
NET WEIGHT	397 lbs. / 180 kg.
GROSS WEIGHT	452 lbs. / 205 kg.
INTERIOR DIMENSIONS	43.3" x 19.29" x 55.12" / 1100 x 490 x 1400 mm
NET DIMENSIONS	49.21" x 26.18" x 84.6" / 1250 x 665 x 2148.84 mm
GROSS DIMENSIONS	52.16" x 30.31" x 87" / 1325 x 770 x 2210 mm

### TECHNICAL DRAWING WITH DIMENSIONS

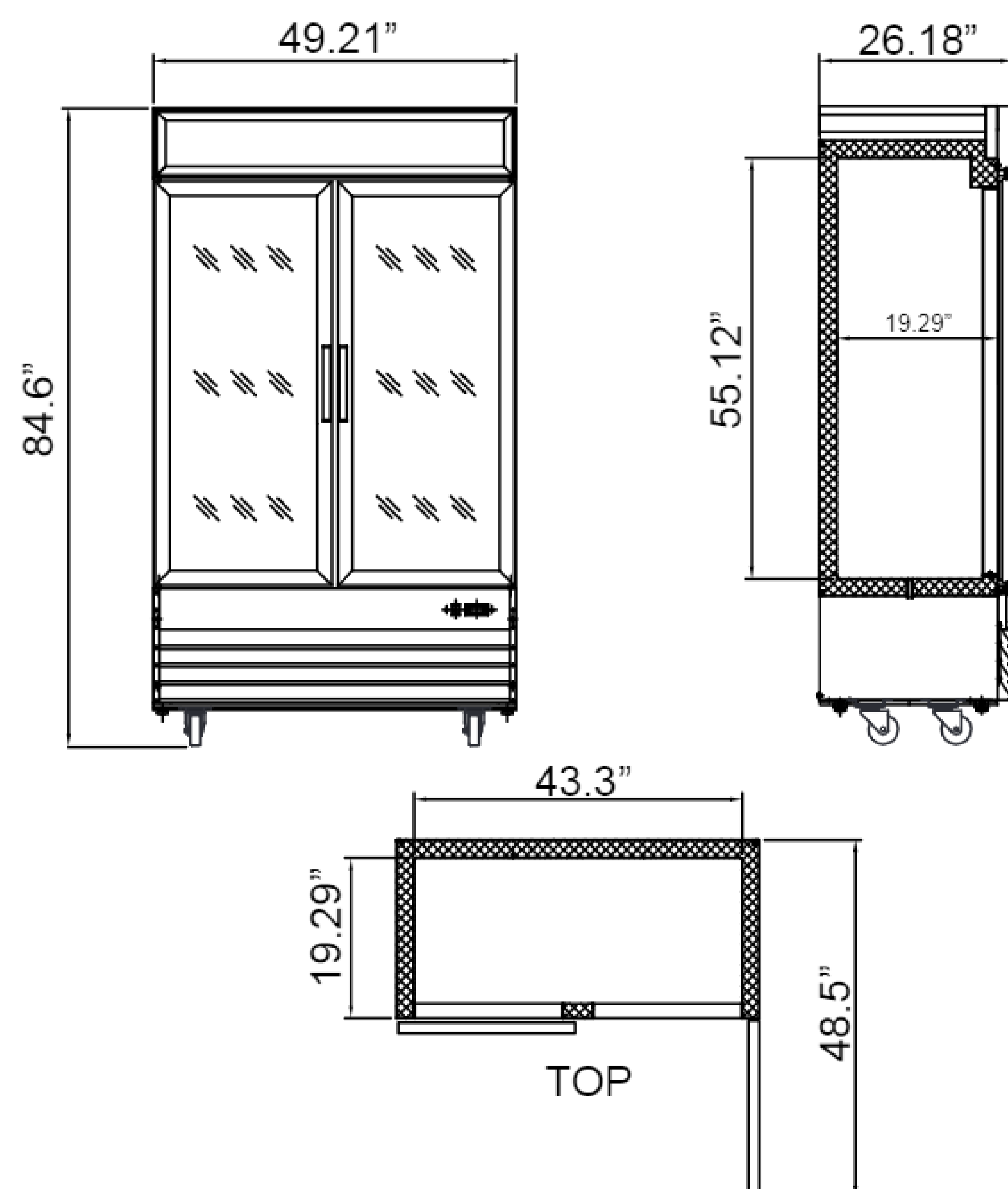

**2 YEAR WARRANTY**  
PARTS AND LABOUR  
5 YEARS ONLY ON COMPRESSOR



Item shipped on pallet  
**NEMA 5-20**

[HTTPS://WWW.NELLAONLINE.COM/PRODUCTS/NELLA-49-GLASS-MERCHANDISING-FREEZER-WITH-2-DOORS](https://www.nellaonline.com/products/nella-49-glass-merchandising-freezer-with-2-doors)



LOCATIONS

**148 NORFINCH DR  
NORTH YORK, ON  
M3N 1X8  
416-740-2424**

**433 QUEEN ST E.  
TORONTO, ON  
M5A 1T5  
416-847-1112**

**1164 ELLESMERE ROAD  
SCARBOROUGH, ON  
M1P 2X4  
416-292-0828**

WWW.NELLAONLINE.COM  
HELP@NELLAONLINE.COM