

Product Image

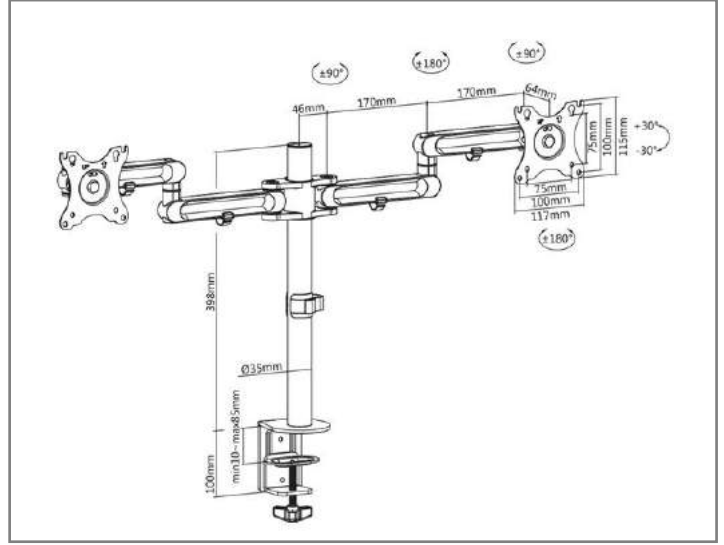

Product Drawing



SMMA1042 Specifications

Material:	Aluminum, Steel
Surface Finish:	Powder Coating
Color:	Matt Black
Product Size:	886x124x498mm
Installation:	Clamp only
Screen Size:	17"-32"
Screen Qty:	2
Weight Range:	2-8Kg
VESA:	100x100;75x75
Tilt:	+30° to -30°
Swivel:	+90° to -90°
Rotate:	+180° to -180°
Max. Arm Extend:	398mm
Clamp Thickness:	10-85mm
Height Adjustable :	Yes
Cable Management:	Yes
Anti-theft:	No
Curved TV:	No
User Manual:	Yes

SMMA1042 Features

- Aluminum Construction provides a more slimline, lighter, more modern look
- Built-in Spring Tension Gauge to assist in install
- Detachable VESA Plate enables easy installation
- Freely Adjusting Height for finding an optimal ergonomic position
- Cable Management to help keep everything organized
- Ideal for offices, homes, public areas, industrial settings, production lines and many more
- Both screens can be rotated 360 degrees so portrait and landscape can be achieved on the same arm.
- Free-Tilting Design: makes easy forward or backward adjustment for better viewing and reduced glare

